

# BECKHOFF New Automation Technology

Manual | EN

## C6030

Industrial PC





# Table of contents

<b>1</b>	<b>Notes on the documentation</b>	<b>5</b>
<b>2</b>	<b>For your safety</b>	<b>6</b>
2.1	Signal words	6
2.2	Intended use	6
2.3	Fundamental safety instructions	7
2.4	Operator's obligation to exercise diligence	7
2.5	Notes on information security	8
<b>3</b>	<b>Product overview</b>	<b>9</b>
3.1	Structure	10
3.2	Interface description	11
3.2.1	Power supply	11
3.2.2	Ethernet RJ45	12
3.2.3	USB	14
3.2.4	DisplayPort	15
3.3	Status LEDs	16
3.3.1	UPS-OCT LED	16
3.3.2	PWR LED	17
3.3.3	HDD LED	17
3.3.4	TC LED	17
3.4	Name plate	18
3.5	TwinCAT version	19
<b>4</b>	<b>Commissioning</b>	<b>20</b>
4.1	Transport and unpacking	20
4.2	Control cabinet installation	21
4.2.1	Mounting options	22
4.2.2	Dimensions	24
4.2.3	Installation in the control cabinet	25
4.3	Connecting the industrial PC	26
4.3.1	Grounding of the Industrial PC	27
4.3.2	Connecting cables and power supply	28
4.4	Switching the industrial PC on and off	29
<b>5</b>	<b>Beckhoff Device Manager</b>	<b>30</b>
<b>6</b>	<b>Decommissioning</b>	<b>32</b>
6.1	Disconnecting the power supply and cables	32
6.2	Disassembly and disposal	33
<b>7</b>	<b>Maintenance</b>	<b>34</b>
7.1	Cleaning	34
7.2	Maintenance	35
7.2.1	Replacing the battery	36
7.2.2	Replacing the storage media	38
7.2.3	Replacing the fan	40
<b>8</b>	<b>Troubleshooting</b>	<b>41</b>

---

<b>9 Technical data</b> .....	<b>42</b>
<b>10 Appendix</b> .....	<b>43</b>
10.1 Service and support .....	43
10.2 Approvals .....	44

# 1 Notes on the documentation

This description is intended exclusively for trained specialists in control and automation technology who are familiar with the applicable national standards.

The documentation and the following notes and explanations must be complied with when installing and commissioning the components.

The trained specialists must always use the current valid documentation.

The trained specialists must ensure that the application and use of the products described is in line with all safety requirements, including all relevant laws, regulations, guidelines, and standards.

## Disclaimer

The documentation has been compiled with care. The products described are, however, constantly under development.

We reserve the right to revise and change the documentation at any time and without notice.

Claims to modify products that have already been supplied may not be made on the basis of the data, diagrams, and descriptions in this documentation.

## Trademarks

Beckhoff®, ATRO®, EtherCAT®, EtherCAT G®, EtherCAT G10®, EtherCAT P®, MX-System®, Safety over EtherCAT®, TC/BSD®, TwinCAT®, TwinCAT/BSD®, TwinSAFE®, XFC®, XPlanar®, and XTS® are registered and licensed trademarks of Beckhoff Automation GmbH.

If third parties make use of the designations or trademarks contained in this publication for their own purposes, this could infringe upon the rights of the owners of the said designations.



EtherCAT® is a registered trademark and patented technology, licensed by Beckhoff Automation GmbH, Germany.

## Copyright

© Beckhoff Automation GmbH & Co. KG, Germany.

The distribution and reproduction of this document, as well as the use and communication of its contents without express authorization, are prohibited.

Offenders will be held liable for the payment of damages. All rights reserved in the event that a patent, utility model, or design are registered.

## Third-party trademarks

Trademarks of third parties may be used in this documentation. You can find the trademark notices here: <https://www.beckhoff.com/trademarks>.

## 2 For your safety

The signal words and their meanings are explained in the chapter on safety. They contain fundamental safety instructions that are essential for preventing personal injuries and damage to property.

### Exclusion of liability

Beckhoff shall not be held liable in the event that this documentation is not complied with and the devices are therefore not used in line with the documented operating conditions.

## 2.1 Signal words

The signal words used in the documentation are classified below.

### Warning on personal injuries

<b>⚠ DANGER</b>
High-risk hazard that will result in death or serious injury.
<b>⚠ WARNING</b>
Medium-risk hazard that may result in death or serious injury.
<b>⚠ CAUTION</b>
Low-risk hazard that may result in minor injury.

### Warning on property and environmental damage

<b>NOTICE</b>
The environment, equipment, or data may be damaged.

## 2.2 Intended use

The device is intended for use as a control system for automation, visualization and communication in machine and system engineering.

The device has been developed for an IP20 working environment. This involves finger protection and protection against solid foreign objects up to 12.5 mm. There is no protection against water. Operation of the devices in wet and dusty environments is not permitted.

The specified limits for technical data must be adhered to.

The device can be used within the documented operating conditions.

### Improper use

Do not use the device outside the documented operating conditions.

## 2.3 Fundamental safety instructions

The following safety instructions must be observed when handling the device.

### Application conditions

- Do not use the device under extreme environmental conditions.
- Only use the device in hazardous areas if it is explicitly designed for this purpose.
- Do not carry out any work on the device while it is live. Always switch off the supply voltage for the device before mounting it, replacing device components or rectifying malfunctions.
- Never plug or unplug connectors during thunderstorms. There is a risk of electric shock.
- Ensure that the device has a protective and functional earth connection.

### Damage to property, loss of data and impairment of functions

- If you change the hardware and software configurations, you must keep within the specified limits of power consumption and power loss (please refer to the respective data sheet).
- Ensure that only trained specialists with a control and automation engineering background, operate the device. Use by unauthorized persons can lead to damage to property and loss of data.
- In the case of a 24 V DC power supply unit, fuse the power supply line according to its cross-section to protect the supply line in the event of a short circuit.
- In case of fire, extinguish the device with powder or nitrogen.

## 2.4 Operator's obligation to exercise diligence

The operator must ensure that

- the products are used only for their intended purpose (see Chapter 2.2 [Intended use](#) [▶ 6]).
- the products are only operated in sound condition and in working order.
- the products are operated only by suitably qualified and authorized personnel.
- the personnel is instructed regularly about relevant occupational safety and environmental protection aspects, and is familiar with the operating instructions and in particular the safety instructions contained herein.
- the operating instructions are in good condition and complete, and always available for reference at the location where the products are used.

## 2.5 Notes on information security

The products of Beckhoff Automation GmbH & Co. KG (Beckhoff), insofar as they can be accessed online, are equipped with security functions that support the secure operation of plants, systems, machines and networks. Despite the security functions, the creation, implementation and constant updating of a holistic security concept for the operation are necessary to protect the respective plant, system, machine and networks against cyber threats. The products sold by Beckhoff are only part of the overall security concept. The customer is responsible for preventing unauthorized access by third parties to its equipment, systems, machines and networks. The latter should be connected to the corporate network or the Internet only if appropriate protective measures have been set up.

In addition, the recommendations from Beckhoff regarding appropriate protective measures should be observed. Further information regarding information security and industrial security can be found in our <https://www.beckhoff.com/secguide>.

Beckhoff products and solutions undergo continuous further development. This also applies to security functions. In light of this continuous further development, Beckhoff expressly recommends that the products are kept up to date at all times and that updates are installed for the products once they have been made available. Using outdated or unsupported product versions can increase the risk of cyber threats.

To stay informed about information security for Beckhoff products, subscribe to the RSS feed at <https://www.beckhoff.com/secinfo>.

### 3 Product overview

To ensure optimal performance and the full scope of services with the TwinCAT 3 control software, Beckhoff recommends using the latest TwinCAT 3 version. In addition, the minimum requirement for the motherboard version of your device is TwinCAT 3 Built 3.xxxx.

The C6030 Industrial PC is part of the series of ultra-compact industrial PCs for space-saving control cabinet installation. It is a high-performance device.

Thanks to the available processors, the industrial PC can be used for the following applications, among others:

- diverse automation and visualization tasks
- wide range of IoT tasks with data preprocessing
- complicated HMI applications
- extensive axis controllers
- short cycle times
- high-volume data handling
- other PC applications

The basic configuration of the C6030 includes the following aspects:

- Intel® processor
- 2 x DRAM SODIMM
- M.2-SSD
- 24 V DC power supply unit

### 3.1 Structure

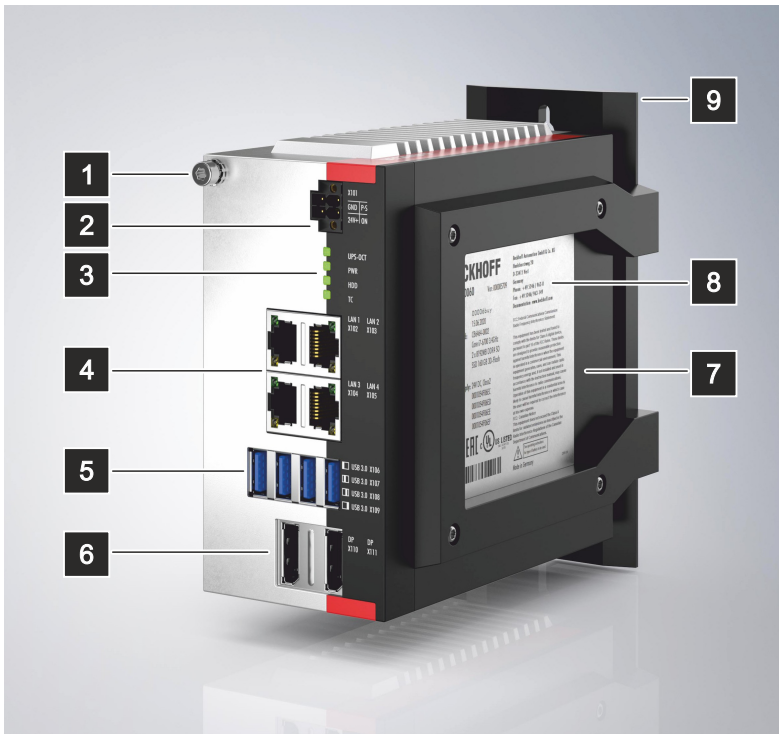

Fig. 1: Structure – basic configuration

Table 1: Key: C6030 structure

No.	Component	Description
1	Protective conductor connection PE	Low-resistance protective earthing and functional earthing of the industrial PC
2	Power supply (X101)	Connection of the power supply and external wiring of the industrial PC
3	Status LEDs	Status display for UPS-OCT, power, mass storage device, TwinCAT
4	Ethernet interfaces RJ45 (X102 - X105)	Connection of the industrial PC to a 100/1000BASE-T network
5	USB interfaces (X106-X109)	Connection of peripheral devices
6	DisplayPorts (X110, X111)	Transmission of the video signal
7	Side cover	Access to battery and storage media
8	Name plate	Information on the equipment of the industrial PC
9	Mounting plate	Plate for mounting the industrial PC over the narrow sides in the control cabinet

## 3.2 Interface description

In the basic configuration, the C6030 includes the following interfaces:

- Power supply (X101)
- Ethernet RJ45 (X102-X105)
- USB (X106-X109)
- DisplayPort (X110, X111)

### 3.2.1 Power supply

The industrial PC is supplied with a nominal voltage of 24 V. The 2x2-pin voltage socket (X101) is used for connection to the power supply and the external wiring of the industrial PC. The main supply voltage is applied between PIN 3 (0 V) and PIN 4 (24 V) of the socket.

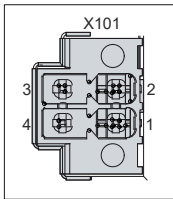

Fig. 2: Voltage socket pin numbering

Table 2: Voltage socket pin assignment

Pin	Signal	Description
1	PC-ON	Input PC-ON
2	P-S	Power status output
3	GND	0 V
4	24 V	Power supply

The plug for the power supply is specified for 8 A and can accommodate wire cross-sections of up to 1.5 mm<sup>2</sup>. For long supply lines, use 1.5 mm<sup>2</sup> cables to achieve a low voltage drop on the supply lines. There should be at least 22 V at the power supply plug of the industrial PC, so that the industrial PC remains switched on during voltage fluctuations. The plug is included in the delivery. You can obtain a replacement plug from your Beckhoff Sales using the following ordering option:

- C9900-P943: power supply connector for C60xx Industrial PC

A maximum cable length of 30 m is permissible for the Power Status output.

### 3.2.2 Ethernet RJ45

The C6030 has four Gigabit LAN ports (X102-X105). The 100Base-T, 1000Base-T, and 2500Base-T Ethernet standards enable the connection of corresponding network components and data rates of 100/1000/2500 Mbit/s. The required speed is selected automatically.

The RJ45 connection technology with twisted-pair cables is used. The maximum length of the cable connection is 100 m.

The controllers are used as follows, based on the device generation:

Table 3: Controller classification based on device generation

Device generation	Controller	Mbit/s
C6030-0060	Intel® i219 (PHY) for LAN1 and Intel® i210 (MAC/PHY) for LAN2-LAN4	100/1000
C6030-0070	Intel® i219 (PHY) for LAN1 and Intel® i210 (MAC/PHY) for LAN2-LAN4	100/1000
C6030-0080	Intel® i219 (PHY) for LAN1 and Intel® i226 (MAC/PHY) for LAN2-LAN4	100/1000/2500

The Ethernet ports (X103-X105, LAN2-LAN4) connected via PCIe® with the i210/i226 controller are suitable for cycle times <= 1 ms and for distributed clock applications with EtherCAT.

The Ethernet port (X102, LAN1) i219 integrated in the chipset is suitable for real-time Ethernet applications with cycle times > 1 ms (without distributed clocks).

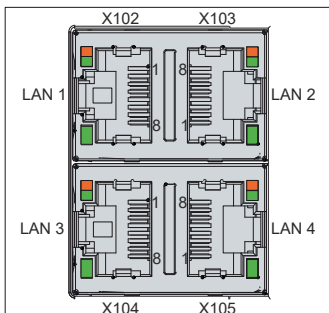

Fig. 3: Ethernet interface pin numbering

Table 4: Ethernet interface pin assignment

Pin	Signal	Description
1	T2 +	Pair 2
2	T2 -	
3	T3 +	Pair 3
4	T1 +	
5	T1 -	Pair 1
6	T3 -	
7	T4 +	Pair 4
8	T4 -	

The LEDs of the LAN interfaces indicate the activity and the data transmission rate (Mbit/s). The LED shown completely green in the figure indicates whether the interface is connected to a network. If this is the case, the LED lights up green. The LED flashes green when data transmission is in progress on the interface.

The green/orange LED shown in the figure indicates the data transmission rate. The device generations differ in terms of the possible data transmission rate. The following tables show the LED meanings according to the possible data transmission rate.

*Table 5: LED meaning speed 100/1000 Mbit/s*

<b>Mbit/s</b>	<b>LED</b>
100	Lights-up orange
1000	Lights up green

*Table 6: LED meaning speed 100/1000/2500 Mbit/s*

<b>Mbit/s</b>	<b>LED</b>
100	Off
1000	Lights-up orange
2500	Lights up green

### 3.2.3 USB

The industrial PC has four USB interfaces (X106-X109). They are used to connect peripheral devices with USB interfaces. The following table shows the interface assignment based on the device generation:

Table 7: USB interfaces based on device generation

Device generation	USB interfaces
C6030-0060	4x USB 3.0 (X106-X109)
C6030-0070	4x USB 3.0 (X106-X109)
C6030-0080	2x USB 3.2 Gen. 2 (X108-X109) 2x USB 3.2 Gen. 1 (X106-X107)

Each of the four USB interfaces supplies up to 900 mA current and is electronically fused. USB ports A and B and USB ports C and D are each protected by a common overcurrent detection. If an overcurrent occurs at one of the ports, the two jointly protected USB ports are switched off.

For the device generation C6030-0070, USB port X108 is only compatible with USB 3.0.

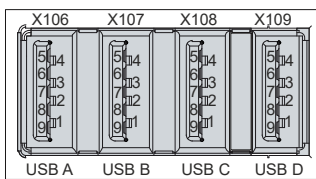

Fig. 4: USB interface pin numbering

Table 8: USB interface pin assignment

Pin	Connection
1	Vbus
2	D -
3	D +
4	GND
5	StdA_SSRX -
6	StdA_SSRX +
7	GND_DRAIN
8	StdA_SSTX -
9	StdA_SSTX +

### 3.2.4 DisplayPort

The industrial PC has two DisplayPorts (X110, X111) that enable connection of devices with DisplayPort. It facilitates transfer of image signals.

In addition, DVI signals can be transferred via an adapter. Please order it from your Beckhoff sales team, quoting order identifier C9900-Z468 adapter cable DisplayPort to DVI, 40 cm.

DisplayPort signals are led out via the interface by default. With an appropriate adapter cable, the card automatically switches to HDMI signals according to the DisplayPort specification.

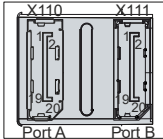

Fig. 5: DisplayPort pin numbering

Table 9: Pin assignment of DisplayPort

Pin	Connection	Pin	Connection
1	LVDS lane 0 +	2	Ground
3	LVDS lane 0 -	4	LVDS lane 1 +
5	Ground	6	LVDS lane 1 -
7	LVDS lane 2 +	8	Ground
9	LVDS lane 2 -	10	LVDS lane 3 +
11	Ground	12	LVDS lane 3 -
13	Config 1	14	Config 2
15	AUX channel +	16	Ground
17	AUX channel -	18	Hot-plug detection
19	Power supply: ground	20	Power supply: 3.3 V / 500 mA

### 3.3 Status LEDs

The industrial PC has four status LEDs: UPS-OCT, PWR, HDD, TC. They provide information on the following aspects:

- the transmission quality of the UPS-OCT signals
- the status of the power controller
- the SSD activity
- the TwinCAT status

The activity of NVM Express™ SSDs is not displayed via the HDD LED.

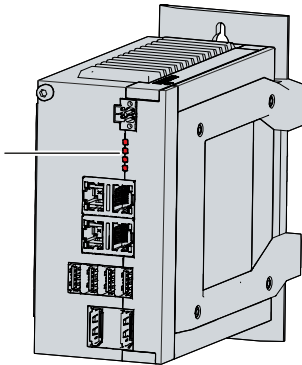

Fig. 6: Status LEDs

#### 3.3.1 UPS-OCT LED

The UPS-OCT LED indicates the transmission quality of the UPS-OCT signals. UPS stands for the uninterruptible power supply. One-cable technology (OCT) enables the communication between PC and UPS to be transmitted together with the power supply, so that only one cable is required.

The colors and flashing intervals have the following meanings:

Table 10: Meaning of the UPS-OCT LED

Color	Flashing interval	Meaning
None	Steadily lit	No UPS-OCT connected
Blue	Flashing	Bootloader active
Yellow	Steadily lit	Moderate signal quality
Green	Steadily lit	Good signal quality
Red	Steadily lit	Poor signal quality

### 3.3.2 PWR LED

The PWR (power) LED indicates the status of the power controller. The colors and flashing intervals have the following meanings:

Table 11: Meaning of the PWR LED

Color	Flashing interval	Meaning
None	Steadily lit	PC is off
White	Steadily lit	VCC power fail
Magenta	Steadily lit	S UPS active (if existent)
Yellow	Steadily lit	Windows shut down, supply voltage still present
Green	Steadily lit	Normal operation
Red	Steadily lit	Reset/power fail
Green/yellow	Flashing	Bootloader running without error
Red/yellow	Flashing	Bootloader is starting (start sequence is being run through)
Magenta	Flashing (0.5 s)	S UPS capacitance test (if S UPS exists)
Red/magenta	Flashing	Checksum error during the I2C transmission in the bootloader
Cyan	Flashing (2 s)	contact Beckhoff Service

### 3.3.3 HDD LED

The HDD LED indicates the activity of the storage medium. The colors and flashing intervals have the following meanings:

Table 12: Meaning of the HDD LED

Color	Flashing interval	Meaning
Red	Flashing	Activity (access to storage medium)

The activity of NVM Express™ SSDs is not displayed via the HDD LED.

### 3.3.4 TC LED

The TC LED indicates the TwinCAT status. The colors and flashing intervals have the following meanings:

Table 13: Meaning of the TC LED

Color	Flashing interval	Meaning
Green	Steadily lit	TwinCAT Run Mode
Blue	Steadily lit	TwinCAT Config Mode
Red	Steadily lit	TwinCAT Stop
-	-	TwinCAT not started

### 3.4 Name plate

The name plate provides information on the equipment fitted to the industrial PC. The name plate shown here serves only as an example.

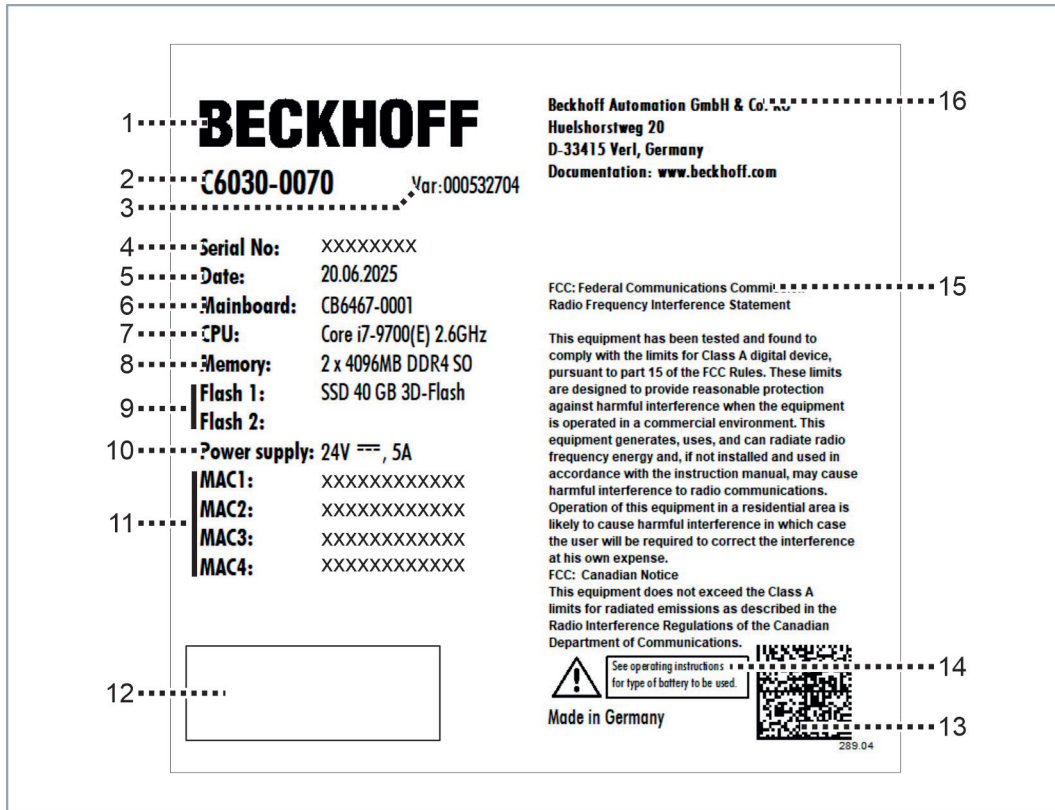



Fig. 7: Name plate

Table 14: Legend for C6030 name plate

No.	Description
1	Vendor
2	Model: The last four digits indicate the device generation.
3	Variant number: commercial number of the order code including ordering options
4	Serial number = Beckhoff Traceability Number (BTN)
5	Date of manufacture
6	Mainboard
7	CPU
8	Main memory
9	SSD
10	Power supply: 24 V DC
11	MAC addresses of the Ethernet interfaces (X102–X105)
12	Symbols  Note: The symbols applicable to the device such as CE, EAC, UKCA,  are located here. The approvals of your device can be found on the name plate and in chapter 10.2 Approvals.
13	BIC
14	Note: Be sure to read the device manual.
15	FCC approval
16	Manufacturer's address

## 3.5 TwinCAT version

To ensure optimal performance and access to all the functions of your device when using the TwinCAT control software, Beckhoff recommends using the latest version of TwinCAT. In addition, you should never go below the minimum requirement for the TwinCAT version. This consists of the hardware requirements and the general TwinCAT system requirements. The general TwinCAT system requirements can be found [here](#). The following table shows the minimum TwinCAT version according to the device generation based on the hardware requirements:

Table 15: Minimum TwinCAT version hardware-based

Device generation	Minimum TwinCAT version hardware-based
C6030-0060	3.1 build 4022.0, 2.11 b2259(x86)
C6030-0070	3.1 build 4024.12
C6030-0080	3.1 build 4024.53

## 4 Commissioning

To be able to use the industrial PC, you must first commission it. The first step is to transport the device to its operating location and unpack it. This is followed by installing the device in the control cabinet, connecting the cables and the power supply and finally switching on the industrial PC.

### 4.1 Transport and unpacking

Note the specified transport and storage conditions (see Chapter 9 [Technical data](#) [▶ 42]).

Despite the robust design of the unit, the components are sensitive to strong vibrations and impacts. Transporting a control cabinet with a built-in PC can result in excessive impact on the industrial PC. During transport the device must therefore be protected from excessive mechanical stress. Appropriate packaging of the industrial PC, in particular the original packaging, can improve the vibration resistance during transport.

#### NOTICE

##### Hardware damage due to condensation

Unfavorable weather conditions during transport can cause damage to the device.

- Protect the device against moisture (condensation) during transport in cold weather or in case of extreme temperature fluctuations.
- Do not put the device into operation until it has slowly adjusted to the room temperature.
- Should condensation occur, wait for about 12 hours before switching the device on.

##### Unpacking

Proceed as follows to unpack the unit:

1. Remove packaging.
2. Keep the packaging for possible future transport.
3. Check your delivery for completeness by comparing it with your order.
4. Check the contents for visible shipping damage.
5. In case of discrepancies between the package contents and the order, or in case of transport damage, please inform Beckhoff Service (see Chapter 10.1 [Service and Support](#) [▶ 43]).

## 4.2 Control cabinet installation

### NOTICE

#### Extreme environmental conditions

Extreme environmental conditions can cause damage to the device.

- Avoid extreme environmental conditions.
- Protect the device against dust, moisture and heat.

### NOTICE

#### Incorrect installation

Incorrect installation in a control cabinet prevents air circulation in the device and causes impaired functioning.

- Only install the device in the orientation specified below.

The device is designed for installation inside a control cabinet in machine and system engineering. The environmental conditions specified for operation must be observed.

Using different mounting plates, you can align the cable entry based on the application requirements.

The following figure shows the two available mounting plates: the standard mounting plate 1 and the optional mounting plate 2. In both cases, the plate is screwed to the right-hand side panel of the industrial PC with four Torx TX10 screws at a tightening torque of approx. 0.5 Nm. You can turn both mounting plates before fastening them such that the PC can be mounted in the desired orientation for the cable entry in the control cabinet (see Chapter 4.2.1 [Mounting options](#) [▶ 22]).

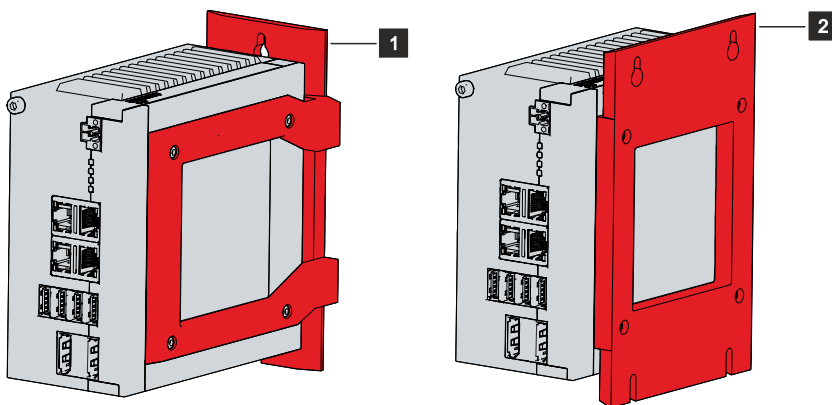

Fig. 8: Mounting plates

The basic version of the industrial PC is supplied with the standard mounting plate 1 already mounted. The scope of delivery does not include any further mounting plates. You can choose the following ordering options:

Table 16: Mounting plate ordering options

Order identifier	Version
C9900-M668	Mounting plate on the side wall, instead of the standard mounting plate
C9900-M669	Mounting plate for lateral mounting of the C603x, single part, not mounted

#### Also see about this

- Technical data [▶ 42]

## 4.2.1 Mounting options

### NOTICE

#### Incorrect installation

Mounting the device in a way that deviates from the documentation can impair its functionality.

- Mount the device only in the orientations shown in the documents.

Before attaching the mounting plates shown in Fig. 8 to the device, you have various options for aligning the device according to the desired cable entry. This results in various options for mounting the device in the control cabinet.

The following drawings show the possible mounting options.

With the standard mounting plate 1, you can mount the industrial PC in the control cabinet using the narrow sides. You have the following mounting options, which are shown in Fig. 9:

- Mounting via the rear panel of the device (A)
- Mounting via the top of the device (B)
- Mounting via the bottom of the device (C)

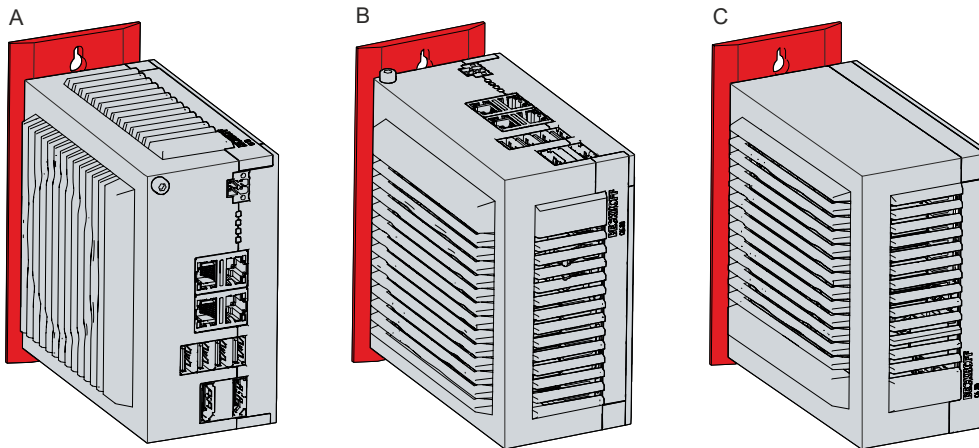

Fig. 9: Mounting options for mounting plate 1

With the optional mounting plate 2, you can mount the industrial PC only via the right-hand side panel. You can rotate the PC as required to align the connections in the control cabinet. You have the following mounting options, which are shown in Fig. 10:

- Connections point upwards (A)
- Connections point downwards (B)
- Connections point to the right (C)
- Connections point to the left (D)

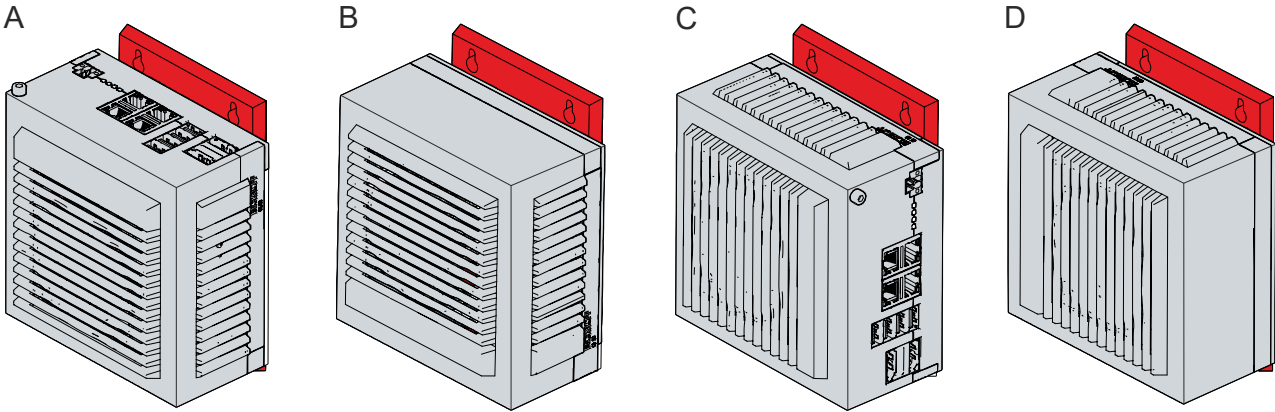

Fig. 10: Mounting options for mounting plate 2

### 4.2.2 Dimensions

The dimensions of the industrial PC and the mounting plates are used to prepare the control cabinet and to mount the device correctly in the control cabinet.

All dimensions are in mm.

The following figure gives an example of the dimensions using the mounting option via the rear panel of the device with mounting plate 1.

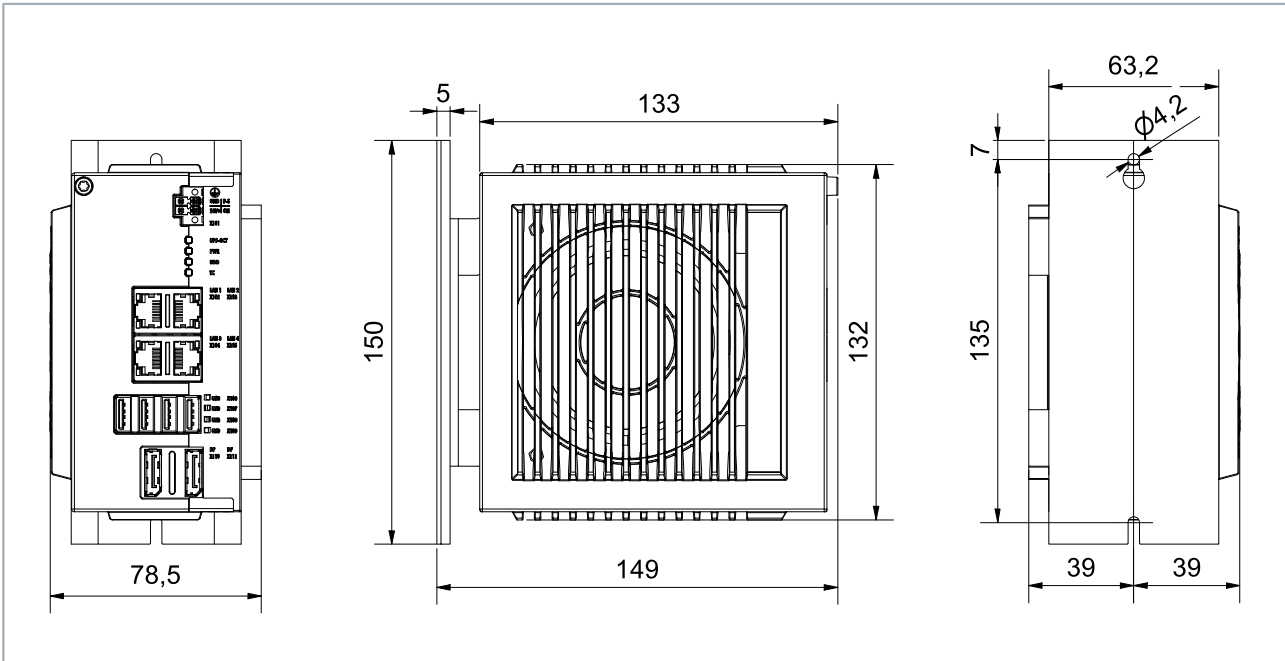

Fig. 11: Mounting plate, rear panel

The following figure gives an example of the dimensions using the mounting option with the connections pointing to the right with mounting plate 2.

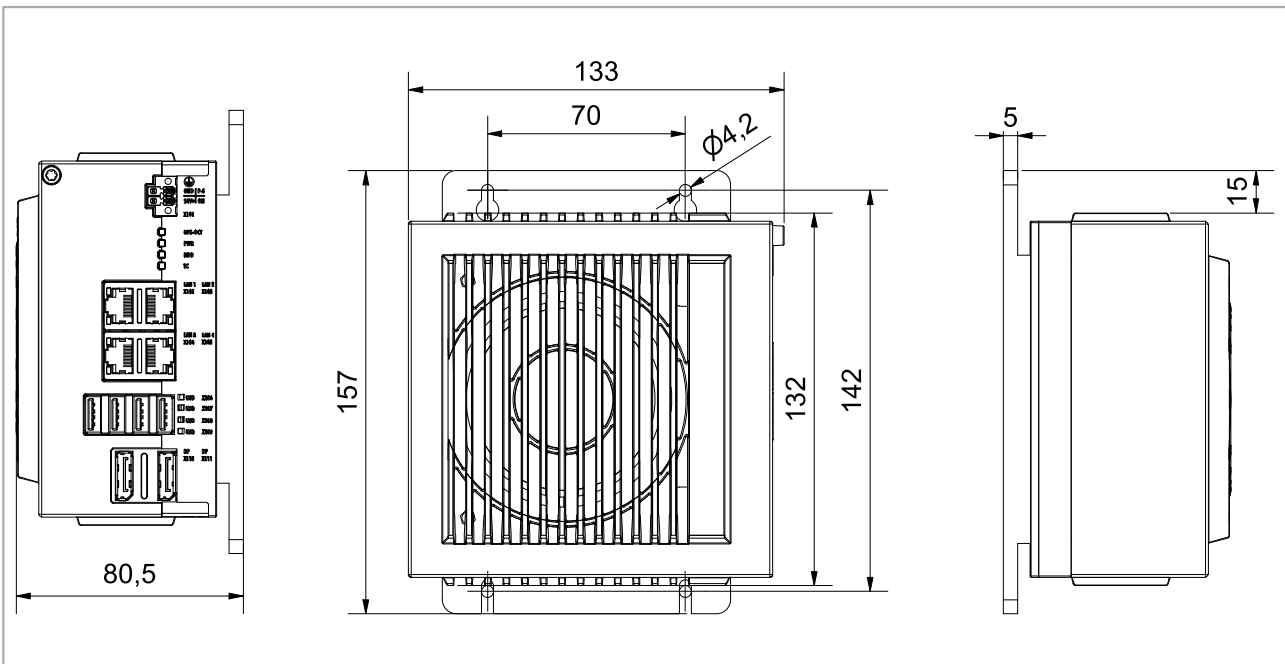

Fig. 12: Mounting plate, side panel

### 4.2.3 Installation in the control cabinet

When installing in the control cabinet, note that there must be 5 cm of free space around the device for air circulation.

#### Mounting via mounting plates

In order to mount the industrial PC with mounting plate 1 or 2 in the control cabinet, it must be furnished with the holes for the fastening screws according to the dimensions of the PC (see Chapter 4.2.2 [Dimensions](#) [► 24]). You need M4 screws for mounting.

After you have drilled the holes for the fastening screws in the control cabinet, you can mount the industrial PC in the control cabinet with mounting plates 1 or 2.

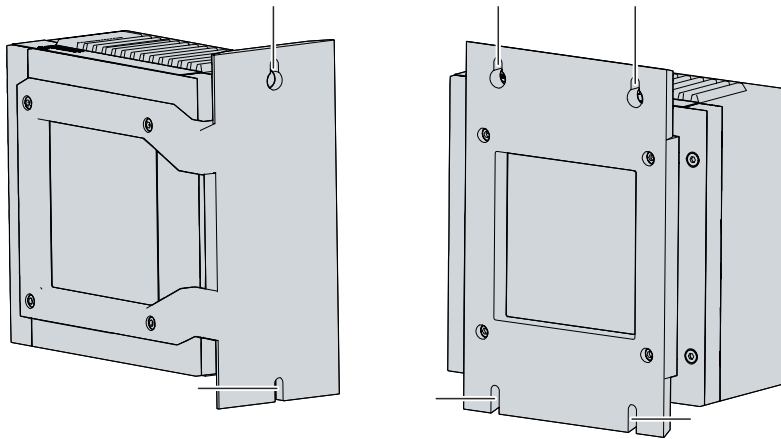

Fig. 13: Mounting plates for control cabinet installation

To install the industrial PC in the control cabinet, follow the steps below:

1. Place the fastening screws in the drill holes in the rear panel of the control cabinet.
  2. Hang the PC on the screws at the marked points of the mounting plate (see previous figure).
  3. Tighten the fastening screws.
- ⇒ You have successfully installed the industrial PC in the control cabinet.

## 4.3 Connecting the industrial PC

### ⚠ CAUTION

#### Risk of electric shock

Dangerous touch voltages can lead to electric shock. To avoid electric shock, observe the following:

- Never connect or disconnect the device cables during a thunderstorm.
- Provide protective earthing for handling the device.

To make the device ready for operation, you have to connect it. The first step is to ground the device. Then you can connect the cables and the power supply.

An external 24 V DC power supply is required to operate the device. A nominal voltage of at least 22 V must be applied to the power supply plug of the device at all times.

The cabling of the panel PC in the control cabinet must be done in accordance with the standard EN 60204-1:2006 PELV = Protective Extra Low Voltage:

- The PE conductor (protective earth) and the "0 V" conductor of the voltage source must be on the same potential (connected in the control cabinet).
- Standard EN 60204-1:2006, section 6.4.1:b stipulates that one side of the circuit, or a point of the energy source for this circuit must be connected to the protective conductor system.

Peripheral devices connected to the device with their own power supply must have the same potential for the PE and "0 V" conductors as the control panel (no potential difference).

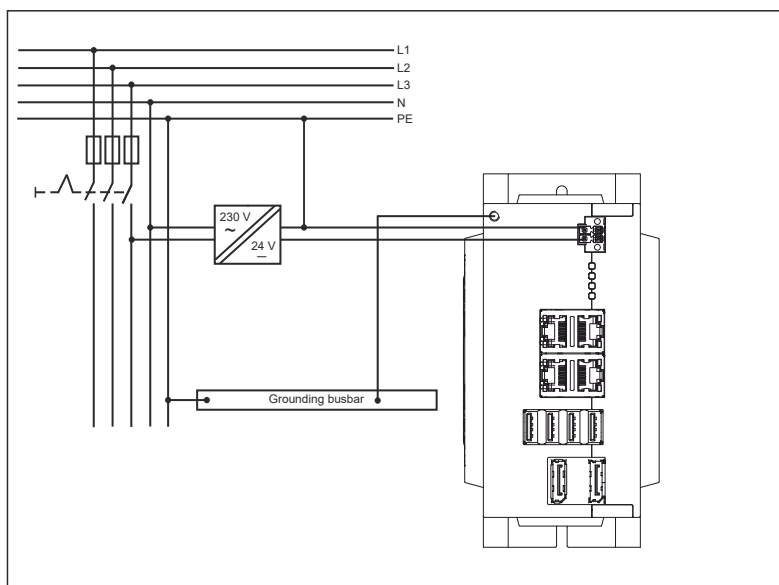

Fig. 14: Wiring example

### 4.3.1 Grounding of the Industrial PC

Potential differences are minimized and electrical currents are diverted to the ground through grounding or potential equalization of electronic devices. This is to prevent dangerous touch voltages and electromagnetic interference.

#### Protective earth

The protective grounding of a device serves to avoid dangerous touch voltages. According to the EN 60204-1 standard (Chapter 8 Potential equalization), protective grounding is required if:

- the device exceeds dimensions of 50 mm x 50 mm,
- the device can be touched or encompassed over a large area,
- contact between the device and active parts is possible,
- an insulation fault may occur.

Establish the low-resistance protective grounding via the PE protective conductor connection on the housing of the industrial PC (see also chapter 3.1 [Structure](#) [▶ 10]) and thus avoid dangerous touch voltages.

#### EMC

#### NOTICE

##### Hardware damage due to electromagnetic interference

The use of the device without a functional earth can lead to material damage due to electromagnetic interference.

- Only use the device with functional earth.

Electromagnetic compatibility (EMC) of the device includes on the one hand not affecting other devices and equipment by electromagnetic interference and on the other hand not being disturbed by electrical or electromagnetic effects itself.

To do this, the device must comply with certain protection requirements. The device has EMC interference immunity according to EN 61000-6-2. The EMC interference emission of the device meets the requirements of EN 61000-6-4.

The functional earth is necessary for the EMC of the device. The functional earthing is also established via the earthing connection between the protective conductor connection on the device and the central grounding point of the control cabinet in which the PC is installed. Use wires with a cross-section of at least 4 mm<sup>2</sup> or a flat conductor for the ground connection, as the circumference of the conductor should be as large as possible.

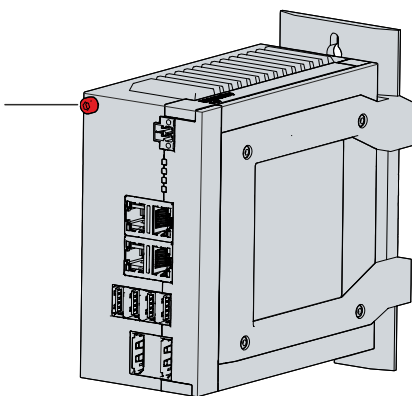

Fig. 15: Protective conductor connection PE

## 4.3.2 Connecting cables and power supply

### NOTICE

#### Incorrect connection procedure

Incorrect procedure when connecting the cables and the power supply can cause hardware damage.

- Follow the documented procedure for connecting the cables and the power supply.
- Always connect the cables first and only then switch on the power supply.
- Please read the documentation for the external devices prior to connecting them.

#### Connecting cables

The connections are located in the front of the industrial PC and are documented in Chapter 3.2 [Interface description](#) [► 11].

Make sure that you first ground the PC (see chapter 4.3.1 [Grounding of the Industrial PC](#) [► 27]) and then plug in all data transmission cables.

#### Connecting the power supply

Cables with a maximum cable cross-section of 1.5 mm<sup>2</sup> can be used for connecting the power supply. Always use 1.5 mm<sup>2</sup> to achieve a low voltage drop on the supply cable. A nominal voltage of at least 22 V must always be applied to the voltage connector of the industrial PC so that the industrial PC remains switched on even during voltage peaks and voltage fluctuations.

The minimum temperature rating of the cable to be connected to the field wiring terminals is 70 °C.

Proceed as follows to connect the 24 V<sub>DC</sub> power supply unit:

1. Install the power supply cable on the power supply plug.
  2. Plug the power supply cable into the four-pin power supply socket of the industrial PC.
  3. Screw the power supply plug to the power supply socket of the industrial PC.
  4. Connect the PC to your external 24 V power supply.
  5. Switch on the 24 V power supply.
- ⇒ You have connected the power supply.

## 4.4 Switching the industrial PC on and off

### NOTICE

#### Public networks

Connecting the device to public networks without additional protective measures can compromise the safety of the device.

- Protect the device before connecting it to public networks.

### NOTICE

#### Data loss due to switching off the device while the software is running

Switching off the device before the running software is terminated and the operating system is shut down can lead to data loss.

- Quit the running software and shut down the operating system before switching off the device.

The industrial PC is started or switched off when the system is switched on or off or when the power supply to the PC is connected or disconnected.

You can use the PC-ON input of the PC to control the startup and shutdown of the operating system. The PC-ON signal is inverted, which is why the operating system boots up at 0 V at the input and shuts down at 24 V. During operation, 0 V must therefore be permanently applied to the input. If you want to shut down the operating system, you must apply 24 V to the PC-ON input. Once the operating system has shut down, the PC power supply unit sets the Power Status output from 24 V to 0 V. This indicates that the shutdown is complete. You can then switch off the power supply. If you remove the 24 V from the PC-ON input before you have switched off the power supply, the operating system restarts. Therefore, 24 V must be applied to the PC-ON input until you have switched off the power supply.

To shut down the operating system properly, you can install an additional ON/OFF switch next to the machine's main switch to turn the machine on and off. The main switch can thus remain switched on in principle and thus ensures that the PC is still supplied with power during the shutdown of the operating system. Via the Power Status output, you can switch, for example, a contactor that switches off the entire system. The load capacity of the Power Status output is limited to max. 0.5 A. No fuse protection is required.

### Driver installation

When you switch on the device for the first time, the optionally pre-installed operating system will be started. For any additional hardware you have connected, you have to install the drivers yourself afterwards. In addition, the Beckhoff Device Manager starts automatically. The Device Manager is a software from Beckhoff that supports you in configuring the device.

If you have ordered the device without an operating system, you must install this and the driver software for the additional hardware you have connected and for the components inside the device. Please follow the instructions in the documentation for the operating system and the additional components.

### UPS software components

The UPS software components with the corresponding drivers must be installed on the PC in order to operate the power supply unit as a UPS. The software components and drivers are already installed on delivery of the PC with operating system. If they are not, you have to install the installation package *Beckhoff UPS* yourself.

You can obtain the installation package from Beckhoff Service ([service@beckhoff.com](mailto:service@beckhoff.com)). You then use the installation package to install the UPS software components. The UPS software components come with a detailed help function. Call up the help files either directly from the configuration register by clicking the Help button or start the file under *Start > Programs > Beckhoff > UPS software components*.

The communication between your PC and the UPS takes place via the BIOS API. In addition to the UPS driver, you also need the Beckhoff Automation Device Driver.

## 5 Beckhoff Device Manager

The Beckhoff Device Manager enables detailed system diagnostics with uniform secure access to the existing hardware and software components. System data is recorded, analyzed and evaluated during operation. The data helps to detect deviations at an early stage and prevent device downtimes.

The user interface screenshots shown in this chapter are examples only and do not represent the actual state of your device.

The Beckhoff Device Manager always starts automatically after the device has been booted. In addition, you have the option of manually starting the previously closed Device Manager at any time.

The device is supplied with predetermined access data by default:

- User name: Administrator
- Password: 1

You also have the option of using the Beckhoff Device Manager to remotely configure the device via a web browser. More detailed information is available in the Beckhoff Device Manager [manual](#).

### First start of Beckhoff Device Manager

When your device is booted for the first time, the Beckhoff Device Manager also starts automatically for the first time. The Security Wizard opens. It informs you that you should reset the default password set by Beckhoff. Proceed as follows:

1. Click **Next** on the Security Wizard start page.
  - ⇒ This will take you to the **Change Passwords** page:

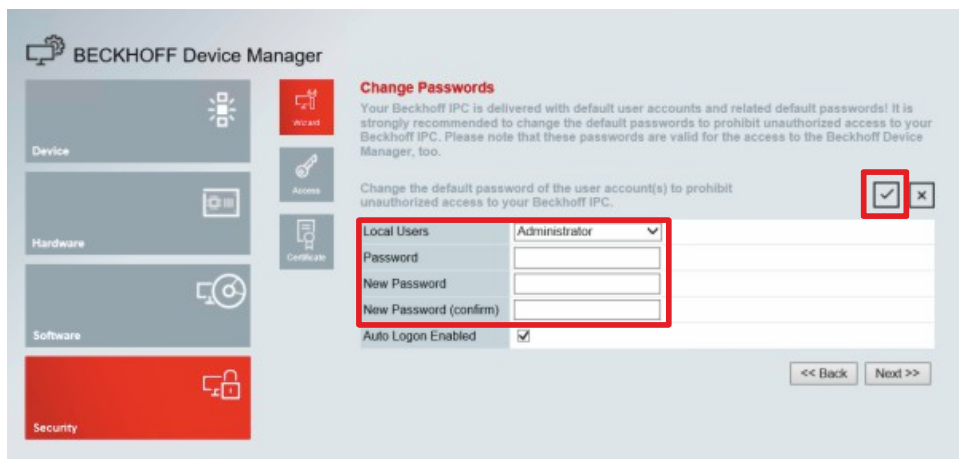

Fig. 16: Beckhoff Device Manager – Change passwords

2. Enter the access data of the Device Manager on delivery.
3. Choose a secure new password. Instructions for choosing a secure password are given below.
4. Confirm the changes by clicking on the tick in the red box on the right.
5. Exit the Security Wizard.
  - ⇒ You have reached the Device Manager start page.

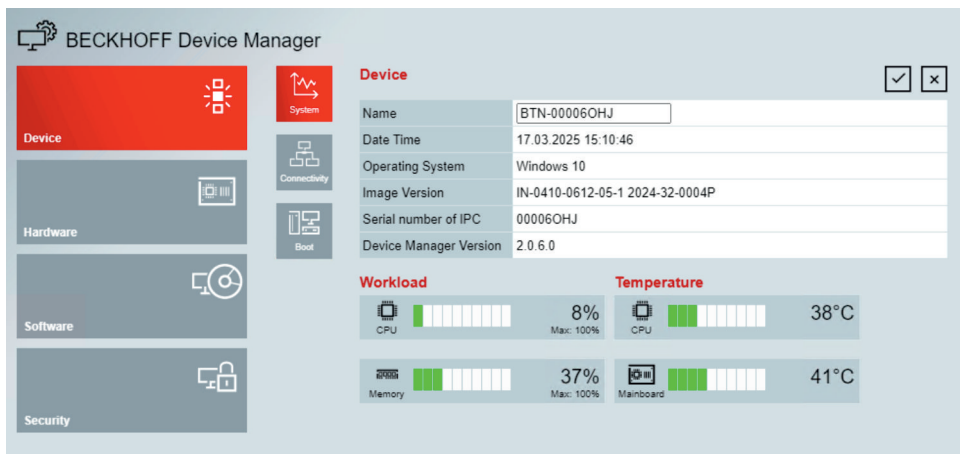

Fig. 17: Beckhoff Device Manager – Start page

Continue to navigate in the menu and to configure the device. Note that modifications only become active once they have been confirmed.

### Manual start of Beckhoff Device Manager

To start the Beckhoff Device Manager manually, proceed as follows:

1. Open a web browser locally on the device.
  2. Enter *localhost/config* in the web browser to start the Beckhoff Device Manager.
- ⇒ The Beckhoff Device Manager starts. The Security Wizard appears.

### Secure passwords

Strong passwords are an important prerequisite for a secure system.

Beckhoff supplies the device images with standard user names and standard passwords for the operating system. It is imperative that you change these.

Controllers are shipped without a password in the UEFI/BIOS setup. Beckhoff recommends assigning a password here as well.

Please note the following:

- Passwords should be unique for each user and service.
- Only change passwords after an incident in which passwords have become known without authorization.
- Train the device users in the use of passwords.

A secure password has the following characteristics:

- Password complexity: The password should contain capital and lower-case letters, numbers, punctuation marks and special characters.
- Password length: The password should be at least 10 characters long.

## 6 Decommissioning

### NOTICE

#### Hardware damage due to power supply

A connected power supply can cause damage to the device during disassembly.

- Disconnect the power supply from the device before starting to disassemble it.

When taking the industrial PC out of operation, you must first disconnect the power supply and cables. You can then remove the device from the control cabinet.

If you do not want to continue using the industrial PC, Chapter 6.2 [Disassembly and disposal](#) [► 33] provides information on the correct disposal of the device.

### 6.1 Disconnecting the power supply and cables

#### ⚠ CAUTION

#### Risk of electric shock

Dangerous touch voltages can lead to electric shock. To avoid electric shock, observe the following:

- Never connect or disconnect the device cables during a thunderstorm.
- Provide protective earthing for handling the device.

Before you remove the industrial PC from the control cabinet, you must disconnect the cables and the power supply. Follow the steps below:

1. Shut down the industrial PC.
  2. Disconnect the PC from your external 24 V power supply.
  3. Unscrew the four-pin power supply connector and pull it out of the PC.
  4. Remove the power supply cable if the four-pin connector is to remain with the PC.
  5. Make a note of the wiring of all data transmission cables if you want to restore the cabling with another device.
  6. Disconnect all data transfer cables from the industrial PC.
  7. Finally, disconnect the ground connection.
- ⇒ You have disconnected the cables and the power supply.

## 6.2 Disassembly and disposal

Before you can remove the industrial PC from the control cabinet, you must first disconnect the power supply and the cables (see chapter 6.1 [Disconnecting the power supply and cables](#) [▶ 32]).

### Disassembly with mounting plates

To remove the industrial PC with the corresponding mounting plate 1 or 2 from the control cabinet, proceed as follows:

1. Loosen the fastening screws just enough so that they remain attached to the control cabinet.
  2. Lift the PC until the fastening screws slide into the keyholes.
  3. Remove the PC from the control cabinet.
- ⇒ You have successfully disassembled the PC.

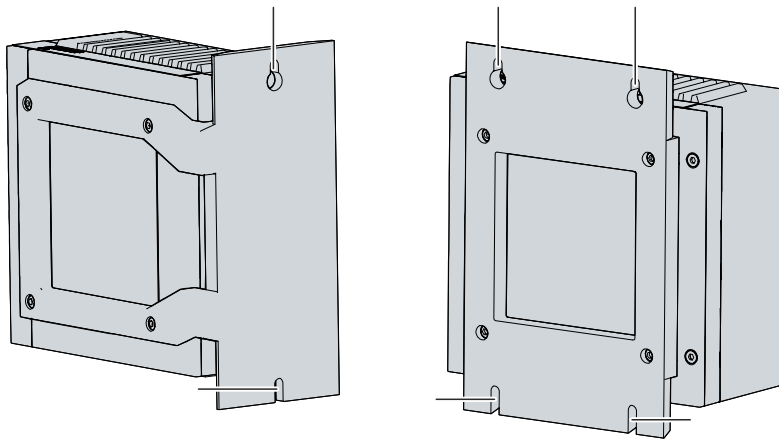

Fig. 18: Positions of the fastening screws

### Disposal of the industrial PC

Be sure to observe the national electronic scrap regulations when disposing of the industrial PC.

In order to dispose of the device, it must be removed and fully dismantled. Dispose of the components in the following way:

- Send plastic parts (polycarbonate, polyamide (PA6.6)) for plastics recycling.
- Take metal parts to the metal recycling collection point.
- Electronic parts such as fans and circuit boards must be disposed of in accordance with national electronic scrap regulations.
- Stick insulating tape over the poles of the CR2032 battery on the motherboard and dispose of the battery via the local battery recycling.

## 7 Maintenance

### ⚠ CAUTION

#### **Risk of electric shock**

Working on the device when live can lead to electric shock.

- Switch off the power supply before replacing device components.

Maintenance measures increase the efficiency of the device by ensuring long-term functionality. Cleaning and maintenance by replacing certain device components contribute to this.

### 7.1 Cleaning

#### NOTICE

#### **Unsuitable cleaning agents**

The use of unsuitable cleaning agents can damage the device.

- Clean the device only as specified.

It is essential to observe the following aspects when cleaning the industrial PC:

- Keep to the boundary conditions of protection rating IP20.
- Only use a vacuum cleaner to clean the PC. The industrial PC does not have to be switched off for this.
- Never use compressed air to clean the PC.
- Maintain an ambient temperature range of 0 °C to +55 °C.

## 7.2 Maintenance

**NOTICE**

**Use of incorrect spare parts**

The use of spare parts not ordered from Beckhoff Service can lead to unsafe and faulty operation.

- Only use spare parts that you have ordered from Beckhoff Service.

Beckhoff devices are manufactured from components of the highest quality and robustness. They are selected and tested for best interoperability, long-term availability and reliable function under the specified environmental conditions.

Nevertheless, some components of the devices may be subject to a limited service life if they are operated under certain conditions, such as at increased ambient temperatures during operation or during storage or during long periods of storage out of operation.

Beckhoff therefore recommends replacing some of the components of the devices after the time after which predictions of the remaining service life of such components can no longer be reliably calculated.

The following table provides recommendations for the regular, precautionary replacement of the device components:

*Table 17: Device component replacement recommendations*

Component	Recommendation for replacement intervals (years)
UPS battery pack	5 years
2.5-inch hard disk	5 years or after 20,000 operating hours at more than 40 °C or after 30,000 operating hours at less than 40 °C
3.5-inch hard disk	5 years, irrespective of the operating hours
Fan	7 years
CFast, SSD, MicroSD, Compact Flash	10 years
Motherboard battery	5 years

Beckhoff is excluded from liability in the event of possible damage occurring during maintenance work. In order to avoid damage caused by electrostatic discharge when replacing device components, protective measures are recommended. Below are some suggestions.

**ESD protection**

**NOTICE**

**Electrostatic discharge**

The replacement of device components without ESD protection can lead to functional impairment and destruction of the device.

- If possible, apply ESD protection measures during maintenance work.

When working on electronic devices, there is a risk of damage due to ESD (electrostatic discharge), which can impair the function or destroy the device.

Protect the device and create an ESD-protected environment in which existing electrostatic charges are safely discharged to ground and charging is prevented.

An ESD-protected environment can best be created by setting up ESD protection zones. The following measures serve this purpose:

- ESD-compliant floors with sufficient conductivity to the reference potential PE;
- ESD-compatible work surfaces such as tables and shelves;
- Wrist grounding strap, especially for sedentary activities;
- grounded and electrostatically dissipating equipment and operating materials (e.g. tools) within the ESD protection zone.

If it is not possible to create an ESD protection zone, you can still protect the device against ESD damage. For example, the following measures can be used:

- Use conductive mats connected to the ground potential as underlays.
- Dissipate possible charges from your own body by touching grounded metal (e.g. control cabinet door).
- Wear a wrist grounding strap.
- Only remove new electronic components from the ESD packaging (tinted plastic bag) after putting on the wrist grounding strap.
- Do not walk around with electronic components in your hand if they are not in ESD packaging.

### Access to exchangeable device components

You can access the device components to be replaced via the cover on the right-hand side. In the first step you gain access to the battery and the storage media. To do this, remove the four Torx TX10 screws and remove the cover (see fig. 18).

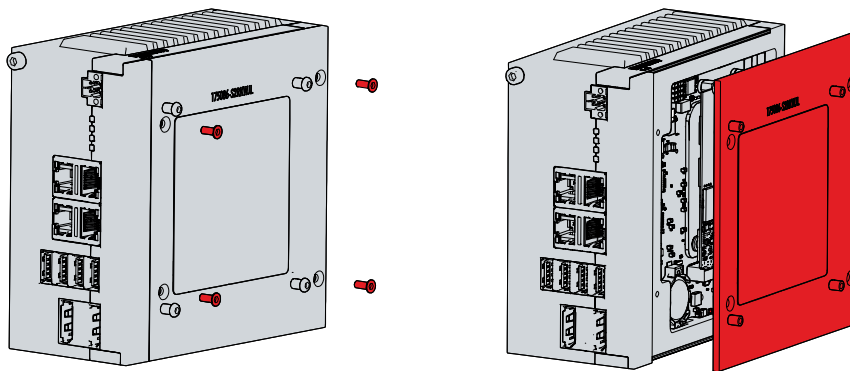

Fig. 19: Access to battery and storage media

You now have access to the battery (1) and storage medium (2) (see fig. 19).

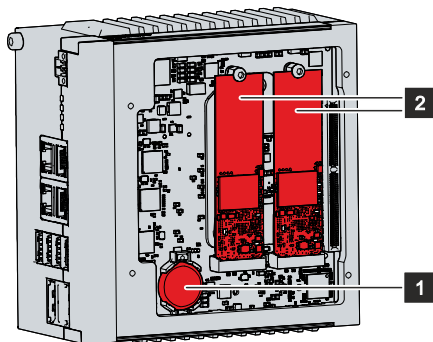

Fig. 20: Battery and storage media

## 7.2.1 Replacing the battery

### ⚠ DANGER

#### Incorrect battery type

Using a different type of battery can lead to a fire or explosion.

- Only replace the battery with a type R/C (BBCV2) battery, article number RC2032, nominal voltage 3 V.
- When replacing the battery, make sure that the polarity is correct.

**⚠ DANGER**

**Incorrect handling of the battery**

Handling the motherboard battery incorrectly can cause an explosion.

- Do not recharge the battery.
- Do not take the battery apart.
- Do not dispose of the battery in fire.
- Do not open the battery.
- Protect the battery against direct sunlight and moisture.

**NOTICE**

**Failure of the electronics due to mechanical damage**

Scratches or damaged components on PCBs can cause the electronics to fail.

- Be very careful when replacing the battery and avoid mechanical damage to the electronics.

The industrial PC does not contain a lithium-ion battery. The motherboard battery is a CR2032 lithium-metal cell. It is used to supply power to the clock integrated on the motherboard. If the battery is depleted or missing, the date and time are displayed incorrectly.

Table 18: Technical data of the battery

Battery type	Electrical properties (at 20 °C)		Dimensions		
	Nominal voltage	Nominal capacity	Diameter	Height	Weight
CR2032	3.0 V	225 mAh	20.0 mm	3.20 mm	3.1 g

Chapter 7.2 [Maintenance](#) [▶ 35] shows how to access the battery. When replacing the battery, make sure that the polarity is correct.

To change the battery, proceed as follows:

1. Place a lever made on the negative pole of the battery holder below the battery.
2. Lift the battery side out of the holder.
  - ⇒ The battery is now in an oblique position (see fig. 20).

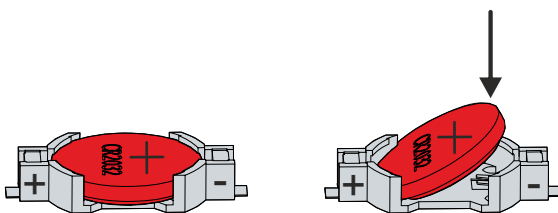

Fig. 21: Battery change

3. Remove the battery completely from the battery holder.
4. Insert the new battery with the correct polarity back into the inclined position on the positive pole of the battery holder. The correct polarity is shown in the figure.
5. Push the high side of the battery down into the battery holder (see fig. 20).
  - ⇒ You have successfully replaced the battery.

**Battery disposal**

To dispose of the battery, remove it, tape off the poles and put it in the battery disposal.

## 7.2.2 Replacing the storage media

For new storage media, please contact your Beckhoff Sales only. SSDs from Beckhoff have a considerably higher lifetime expectancy than commercially available SSDs.

Be sure to shut down and power off the device before replacing SSDs.

### Data transmission before replacement

If you want to exchange a storage medium according to Beckhoff's recommendation, you must copy the data from the old to the new storage medium. You can use the Beckhoff Service Tool (BST) for this purpose. BST is a graphical backup and restore program for devices with a Windows operating system. You can create an image of your operating system and use it to back up the operating system. Then you can restore the created image to a new data carrier. The BST is available on a bootable BST USB flash drive. This includes Windows and a backup tool. Select the size of the BST USB flash drive according to the size of the backup copy of your operating system. You can then keep the flash drive as a backup copy. For this purpose, the BST USB flash drives are designed for particularly long data preservation by means of special flash. For more information on the function of the BST, please refer to the corresponding [manual](#).

If your storage medium is defective and there is no backup, Beckhoff Service can provide you with a fresh Windows image. For this to be possible, your Beckhoff device must already have been delivered with a valid operating system license. After installing the fresh image, the applications must be reinstalled.

If you have mirrored two SSDs in a RAID configuration and one of them has failed, you must first identify the faulty disk. You can check in the runtime of your operating system which SSD you have to replace, Port 0 or Port 1. Fig. 21 shows the position of Port 0 and Port 1 in the industrial PC. Please note the following:

- For the generation C6030-0060, diagram A in the figure applies.
- For the generations C6030-0070/-0080, diagram B in the figure applies.

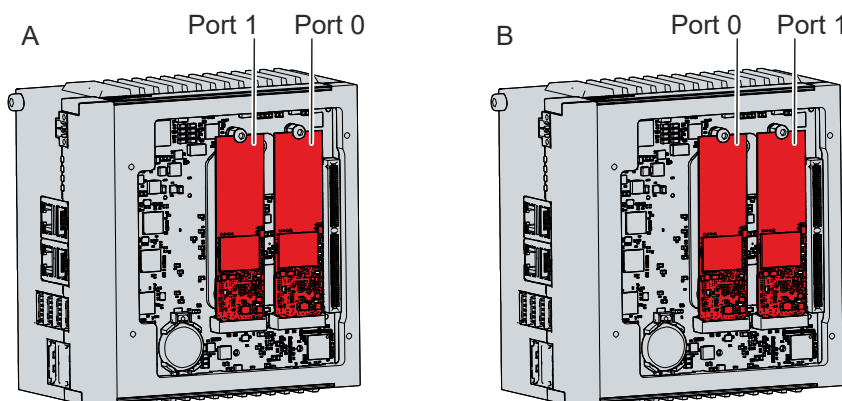

Fig. 22: Port assignment

### Exchange SSD

Chapter 7.2 [Maintenance](#) [▶ 35] shows how to access the SSD.

To replace the SSD, follow the steps shown below in Fig. 22:

1. Remove the Torx TX10 fastening screw of the SSD you want to remove (section A).  
⇒ The SSD automatically places itself in an inclined position (section B).
2. Pull the SSD out of the slot in the inclined position (section C).

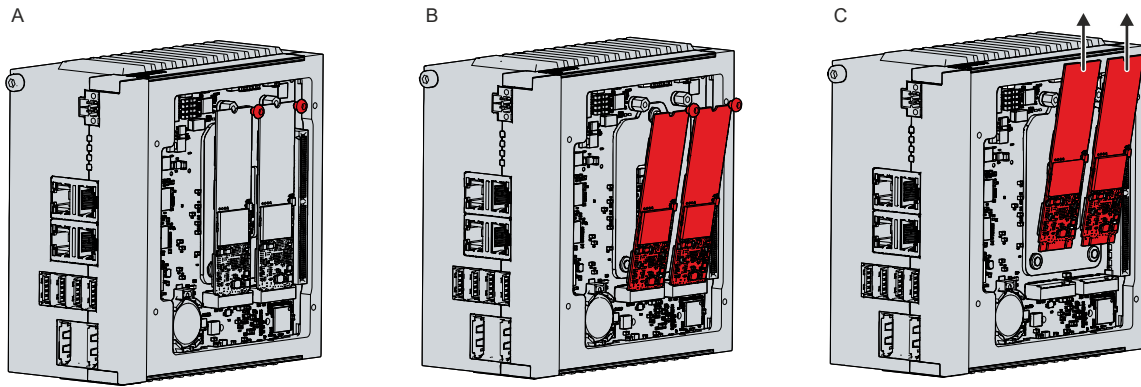

Fig. 23: Replacing the storage media

3. Insert the new SSD into the slot in the same inclined position.
  4. Push down the protruding side of the SSD.
  5. Replace the fixing screw and tighten it to a tightening torque of approx. 0.3 Nm.
- ⇒ You have replaced the SSD.

The old SSD must be disposed of in accordance with the national electronic scrap regulations.

## 7.2.3 Replacing the fan

### NOTICE

#### Incorrect fan type

The device may be damaged if the wrong type of fan is installed.

- Only replace the fans with replacement fans from Beckhoff Service.

The fans ensure optimal cooling of the device. Order replacement fans only from Beckhoff. Please get in touch with your Beckhoff sales contact.

To replace the fan, follow the steps below as shown in Figure 23:

1. Remove the two logo strips on the top and bottom of the industrial PC (section A). You can obtain replacement strips from your Beckhoff Service (see Chapter 10.1, Service and Support).
2. Remove the four Torx TX10 screws at the top and bottom of the PC (section B).
3. Remove the fan housing (section C).
4. Remove the two Torx screws to detach the fan from the fan plate (section D).

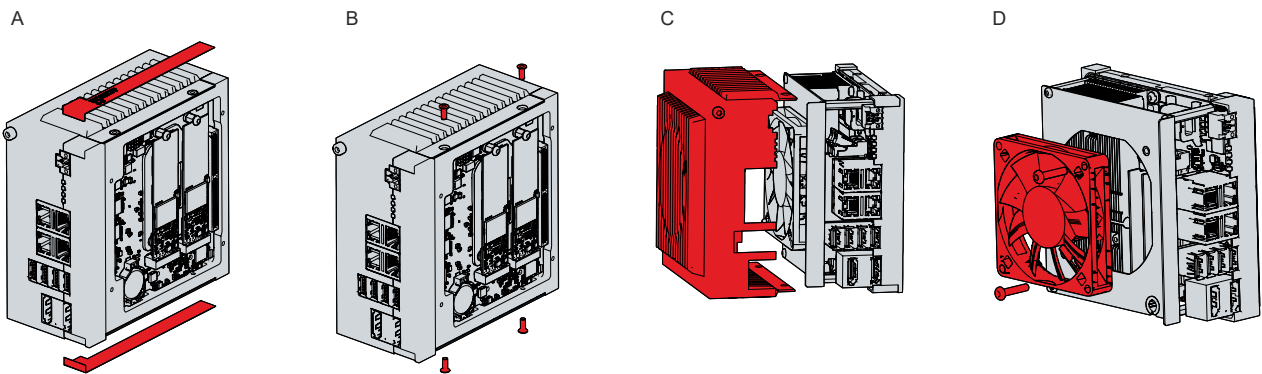

Fig. 24: Fan access

5. Disconnect the fan power cable from the motherboard and pull it out of the cable sleeve.
  - ⇒ You can now replace the fan.
6. Pull the supply cable of the new fan through the cable sleeve and plug it into the motherboard.
7. Attach the fan to the fan plate with the two Torx screws and a tightening torque of approx. 0.5 Nm.
  - ⇒ You have successfully replaced the fan.

The old fan must be disposed of in accordance with the national electronic waste regulations.

## 8 Troubleshooting

<b>Fault</b>	<b>Cause</b>	<b>Measures</b>
No function of the device	No power supply to the device Other cause	Check the power supply cable Call Beckhoff Service
The device does not boot fully	BIOS setup settings are incorrect Other causes	Check BIOS setup settings (load defaults) Call Beckhoff Service
The device boots, software starts, but control does not operate correctly	The cause of the error is the software or plant parts outside of the device	Call the machine and software manufacturer
USB error during access with TwinCAT via USB	Cycle times in TwinCAT set to 10 ms (default)	Increase the cycle times to between 50 ms and 80 ms

## 9 Technical data

Table 19: Technical data

Product designation	C6030
Dimensions (W x H x D)	132 x 133 x 76 mm, without mounting plate
Weight	approx. 1460 g without mounting plate approx. 1700 g with mounting plate
Supply voltage	22-30 V <sub>DC</sub> (24 V <sub>DC</sub> power supply unit)
Power consumption	Data sheet power consumption and power loss in the download finder: <a href="https://www.beckhoff.com/en-en/support/download-finder/search-result/?download_group=691754572">https://www.beckhoff.com/en-en/support/download-finder/search-result/?download_group=691754572</a>
Secure element	fTPM 2.0 enabled (see TPM manual)
Protection rating	IP20
Vibration resistance (sinusoidal vibration)	EN 60068-2-6: 10 to 58 Hz: 0.035 mm 58 to 500 Hz: 0.5 G (approx. 5 m/s <sup>2</sup> )
Shock resistance (shock)	EN 60068-2-27: 5 G (approx. 50 m/s <sup>2</sup> ), duration: 30 ms
EMC interference immunity	conforms to EN 61000-6-2
EMC interference emission	conforms to EN 61000-6-4
Permissible ambient temperature	0 °C to +55 °C (operation) -25 °C...+65 °C (transport / storage)
Permissible air humidity	Maximum 95 %, no condensation
Transport and storage	The same values for air humidity and shock resistance are to be observed during transport and storage as in operation. The shock resistance during transport can be improved by means of suitably packing the industrial PC.

## 10 Appendix

In the appendix you will find information for servicing and details of the approvals that your device has.

### 10.1 Service and support

Beckhoff and its worldwide subsidiaries offer comprehensive service and support, providing fast and competent assistance for all issues relating to Beckhoff products and system solutions.

#### **Beckhoff Service**

The Beckhoff Service Center provides support in all forms of after-sales service:

- on-site service
- repair service
- spare parts service
- hotline service

Hotline: + 49 5246/963-460  
email: [service@beckhoff.com](mailto:service@beckhoff.com)

If your device requires attention, please state its serial number, which you can find on the name plate.

#### **Beckhoff Support**

Support offers you comprehensive technical assistance to help you with the application of individual Beckhoff products, and also with other extensive services:

- world-wide support
- design, programming, and commissioning of complex automation systems
- extensive training program for Beckhoff system components

Hotline: + 49 5246/963-157  
email: [support@beckhoff.com](mailto:support@beckhoff.com)

#### **Headquarters**

Beckhoff Automation GmbH & Co. KG  
Hülshorstweg 20  
33415 Verl  
Germany

Phone: + 49 5246/963-0  
email: [info@beckhoff.de](mailto:info@beckhoff.de)

The addresses of the worldwide Beckhoff branches and agencies can be found on our website at <http://www.beckhoff.com/>.

You can also find further documentation for Beckhoff components there.

## 10.2 Approvals

Your device has at least the following approvals:

- CE
- EAC
- UKCA
- FCC

You will find all other applicable approvals on the name plate of your device.

### **FCC approvals for the United States of America**

FCC: Federal Communications Commission Radio Frequency Interference Statement

This device was tested and complies with the limits for a digital device of class A, according part 15 of the FCC regulations. These limits are designed to provide adequate protection against adverse interference, if the device is used in a commercial environment. This device generates, uses and may emit radio frequency energy and may cause adverse interference with radio communications, if it is not installed and used in accordance with the operating instructions. If this device is used in a residential area it is likely to cause adverse interference, in which case the user must take appropriate countermeasures in order to eliminate the interference at his own expense.

### **FCC approvals for Canada**

FCC: Canadian Notice

This device does not exceed the class A limits for radiation, as specified by the Radio Interference Regulations of the Canadian Department of Communications.

## List of figures

Fig. 1	Structure – basic configuration.....	10
Fig. 2	Voltage socket pin numbering.....	11
Fig. 3	Ethernet interface pin numbering.....	12
Fig. 4	USB interface pin numbering.....	14
Fig. 5	DisplayPort pin numbering.....	15
Fig. 6	Status LEDs.....	16
Fig. 7	Name plate.....	18
Fig. 8	Mounting plates.....	21
Fig. 9	Mounting options for mounting plate 1.....	22
Fig. 10	Mounting options for mounting plate 2.....	23
Fig. 11	Mounting plate, rear panel.....	24
Fig. 12	Mounting plate, side panel.....	24
Fig. 13	Mounting plates for control cabinet installation.....	25
Fig. 14	Wiring example.....	26
Fig. 15	Protective conductor connection PE.....	27
Fig. 16	Beckhoff Device Manager – Change passwords.....	30
Fig. 17	Beckhoff Device Manager – Start page.....	31
Fig. 18	Positions of the fastening screws.....	33
Fig. 19	Access to battery and storage media.....	36
Fig. 20	Battery and storage media.....	36
Fig. 21	Battery change.....	37
Fig. 22	Port assignment.....	38
Fig. 23	Replacing the storage media.....	39
Fig. 24	Fan access.....	40

## List of tables

Table 1	Key: C6030 structure .....	10
Table 2	Voltage socket pin assignment .....	11
Table 3	Controller classification based on device generation .....	12
Table 4	Ethernet interface pin assignment.....	12
Table 5	LED meaning speed 100/1000 Mbit/s .....	13
Table 6	LED meaning speed 100/1000/2500 Mbit/s .....	13
Table 7	USB interfaces based on device generation .....	14
Table 8	USB interface pin assignment.....	14
Table 9	Pin assignment of DisplayPort .....	15
Table 10	Meaning of the UPS-OCT LED .....	16
Table 11	Meaning of the PWR LED .....	17
Table 12	Meaning of the HDD LED.....	17
Table 13	Meaning of the TC LED.....	17
Table 14	Legend for C6030 name plate.....	18
Table 15	Minimum TwinCAT version hardware-based .....	19
Table 16	Mounting plate ordering options .....	21
Table 17	Device component replacement recommendations .....	35
Table 18	Technical data of the battery .....	37
Table 19	Technical data.....	42

## **Trademark statements**

Beckhoff®, ATRO®, EtherCAT®, EtherCAT G®, EtherCAT G10®, EtherCAT P®, MX-System®, Safety over EtherCAT®, TC/BSD®, TwinCAT®, TwinCAT/BSD®, TwinSAFE®, XFC®, XPlanar® and XTS® are registered and licensed trademarks of Beckhoff Automation GmbH.

## **Third-party trademark statements**

Intel, the Intel logo, Intel Core, Xeon, Intel Atom, Celeron and Pentium are trademarks of Intel Corporation or its subsidiaries.

Microsoft, Microsoft Azure, Microsoft Edge, PowerShell, Visual Studio, Windows and Xbox are trademarks of the Microsoft group of companies.

More Information:  
[www.beckhoff.com/C6030](http://www.beckhoff.com/C6030)

Beckhoff Automation GmbH & Co. KG  
Hülshorstweg 20  
33415 Verl  
Germany  
Phone: +49 5246 9630  
[info@beckhoff.com](mailto:info@beckhoff.com)  
[www.beckhoff.com](http://www.beckhoff.com)

