

2-JAW PARALLEL GRIPPERS

SERIES GPP5000

▶ PRODUCT ADVANTAGES

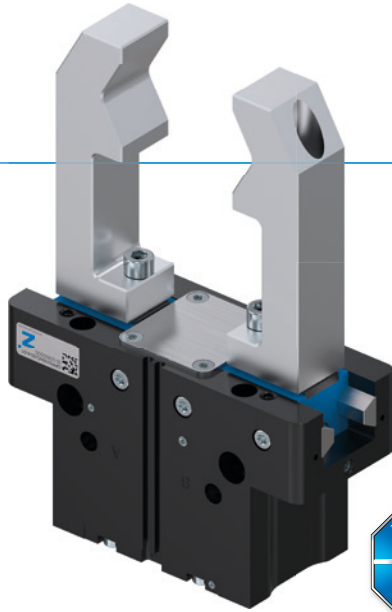

reddot design award
winner 2018



“The best”

▶ **Steel Linear Guide –**

The superior guidance system concept

The steel / steel guide stands for lasting precision, durability and a long service life—featuring maintenance intervals of up to 30 million gripping cycles. Benefit from these features and increase the profitability and process reliability of your machine.

▶ **Leakproof and corrosion protected – The universal gripper**

Suitable for virtually all ambient conditions, with a sealed guide up to IP67 and corrosion protection as standard, you are able to use this gripper universally. As a result, the range of models in your production is reduced, along with a reduction in associated storage and process costs.

▶ **The value promise – Consistent and without fine print**

Rely on the Zimmer Group and benefit from an exclusive 24-month warranty for your GPP and GPD5000 grippers – without restrictions, even for parts that come into contact with the workpiece and wear parts. Maximum reliability, maximum productivity – 24/7!

▶ BENEFITS IN DETAIL

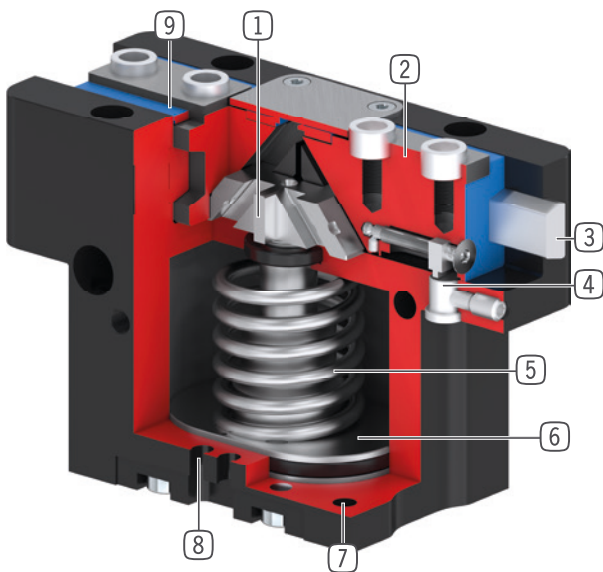

① **Wedge hook mechanism**

- Supports to absorb high forces and moments
- Synchronized gripper jaw movement

② **Gripper jaw**

- Gripper fingers mounted using removable centering sleeves
- Lubricated for life via incorporated lubrication slots

③ **Steel Linear Guide**

- Steel in steel guide
- Enables use of extremely long gripper fingers

④ **Mounting block**

- mounting for inductive proximity switch

⑤ **Integrated gripping force safety device**

- Spring built into cylinder chamber as an energy store

⑥ **Drive**

- Double-acting pneumatic rotor cylinder

⑦ **Mounting and positioning**

- Alternatively, on several sides for customized mounting
- Pneumatic and electrical versions identical apart from height

⑧ **Sensing slot**

- mounting and positioning of magnetic field sensors

⑨ **Dual lip seal**

- IP64 and up to IP67 (with purged air) for Protector version
- Prevents grease from being squeezed out, increasing service life



► SERIES CHARACTERISTICS

Installation size		Variants			
GPP50XX		-00	-20	-21	-24
N	Long stroke	•	•	•	•
NC	Long stroke / Spring closing	•	•	•	•
NO	Long stroke / Spring opening	•	•	•	•
S	High-strength	•	•	•	•
SC	High-strength / Spring closing	•	•	•	•
SO	High-strength / Spring opening	•	•	•	•
	Steel Linear Guide	•	•	•	•
	30 million maintenance-free cycles (max.)	•	•	•	•
	Inductive sensor	•	•	•	•
	Magnetic field sensor	•	•	•	•
	Protected against corrosion	•	•	•	•
	Purged air	•	•	•	•
	Temperature-resistant		•		•
	Cleanroom-certified	•		•	
	IP64	•	•		
	IP67*			•	•

* with purged air (max. 0,5 bar)

► TECHNICAL DATA

Installation size	Stroke per jaw	Gripping force	Weight	IP class
	[mm]	[N]	[kg]	
GPP5003	2,5	140 - 215	0,08 - 0,12	IP64 / IP67*
GPP5004	2 - 4	200 - 630	0,15 - 0,3	IP64 / IP67*
GPP5006	3 - 6	330 - 1080	0,28 - 0,44	IP64 / IP67*
GPP5008	4 - 8	520 - 1670	0,53 - 0,76	IP64 / IP67*
GPP5010	5 - 10	885 - 2890	0,85 - 1,31	IP64 / IP67*
GPP5013	6 - 13	1410 - 4400	1,5 - 2,26	IP64 / IP67*
GPP5016	8 - 16	2090 - 6600	2,9 - 4,4	IP64 / IP67*
GPP5025	14 - 25	3280 - 9130	6,1 - 8,75	IP64 / IP67*
GPP5030	17 - 30	5000 - 13550	9,2 - 13,7	IP64 / IP67*
GPP5035	20 - 35	6100 - 15900	15,8 - 23,3	IP64 / IP67*
GPP5045	26 - 45	10200 - 26950	33 - 50	IP64 / IP67*

* with purged air (max. 0,5 bar)

2-JAW PARALLEL GRIPPERS

INSTALLATION SIZE GPP5006

▶ PRODUCT SPECIFICATIONS

-00-A / -20-A / -21-A / -24-A

Steel / steel guide

▶ Gripping force diagram

Shows the arithmetic total of the individual forces that occur on the gripper fingers, depending on the gripper finger length

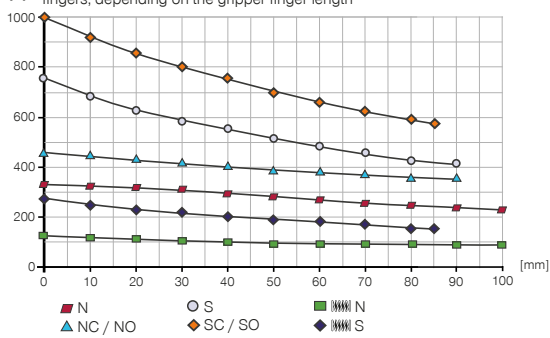

▶ Forces and moments

Displays static forces and moments that can also have an effect, besides the gripping force.

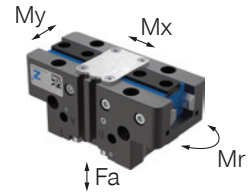

Mr [Nm]	43
Mx [Nm]	70
My [Nm]	46
Fa [N]	1250

▶ VARIANTS

-00-A / -20-A

Steel / steel guide

-21-A / -24-A

Steel / steel guide



▶ TECHNICAL DATA

Order no.	▶ Technical data					
	GPP5006N-00-A	GPP5006NC-00-A	GPP5006NO-00-A	GPP5006S-00-A	GPP5006SC-00-A	GPP5006SO-00-A
Stroke per jaw [mm]	6	6	6	3	3	3
Gripping force in closing [N]	330	455		740	1020	
Gripping force in opening [N]	360		485	800		1080
Gripping force secured by spring min. [N]		125	125		280	280
Closing time [s]	0.025	0.015	0.035	0.025	0.015	0.035
Opening time [s]	0.025	0.035	0.015	0.025	0.035	0.015
Dead weight of mounted gripper finger max. [kg]	0.4	0.4	0.4	0.4	0.4	0.4
Length of the gripper fingers max. [mm]	100	90	90	100	85	85
Repetition accuracy +/- [mm]	0.01	0.01	0.01	0.01	0.01	0.01
Operating pressure [bar]	3 ... 8	4 ... 7	4 ... 7	3 ... 8	4 ... 7	4 ... 7
Nominal operating pressure [bar]	6	6	6	6	6	6
Operating temperature [°C]	-10 ... +90	-10 ... +90	-10 ... +90	-10 ... +90	-10 ... +90	-10 ... +90
Air volume per cycle [cm ³]	11	24	24	11	24	24
Clean room applications according to DIN EN ISO 14644-1	6	6	6	6	6	6
Certifications	LABS / REACH / RoHS	LABS / REACH / RoHS	LABS / REACH / RoHS	LABS / REACH / RoHS	LABS / REACH / RoHS	LABS / REACH / RoHS
Protection to IEC 60529	IP64	IP64	IP64	IP64	IP64	IP64
Protected against corrosion	Yes	Yes	Yes	Yes	Yes	Yes
Weight [kg]	0.28	0.35	0.34	0.29	0.36	0.35

Order no.	▶ Technical Data - High Temperature Version					
	GPP5006N-20-A	GPP5006NC-20-A	GPP5006NO-20-A	GPP5006S-20-A	GPP5006SC-20-A	GPP5006SO-20-A
Operating temperature [°C]	-10 ... +130	-10 ... +130	-10 ... +130	-10 ... +130	-10 ... +130	-10 ... +130

Order no.	▶ Technical Data - Protector Version					
	GPP5006N-21-A	GPP5006NC-21-A	GPP5006NO-21-A	GPP5006S-21-A	GPP5006SC-21-A	GPP5006SO-21-A
Clean room applications according to DIN EN ISO 14644-1	5	5	5	5	5	5
Protection to IEC 60529	IP67*	IP67*	IP67*	IP67*	IP67*	IP67*
Weight [kg]	0.36	0.43	0.42	0.37	0.44	0.43

Order no.	▶ Technical Data - High Temperature Protector Version					
	GPP5006N-24-A	GPP5006NC-24-A	GPP5006NO-24-A	GPP5006S-24-A	GPP5006SC-24-A	GPP5006SO-24-A
Operating temperature [°C]	-10 ... +130	-10 ... +130	-10 ... +130	-10 ... +130	-10 ... +130	-10 ... +130
Protection to IEC 60529	IP67*	IP67*	IP67*	IP67*	IP67*	IP67*
Weight [kg]	0.36	0.43	0.42	0.37	0.44	0.43

*with purged air (max. 0,5 bar)

▶ Maximum gripper finger length

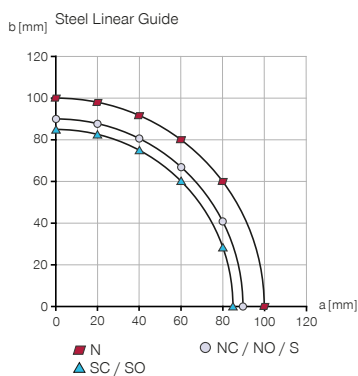

▶ Resulting gripper finger length for determining the gripping force

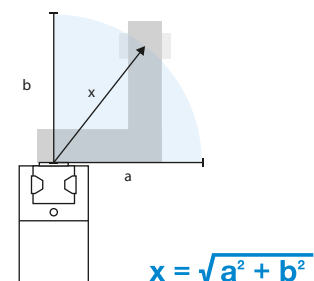

2-JAW PARALLEL GRIPPERS

INSTALLATION SIZE GPP5006

TECHNICAL DRAWINGS

NC / NO / SC / SO
-00-A / -20-A

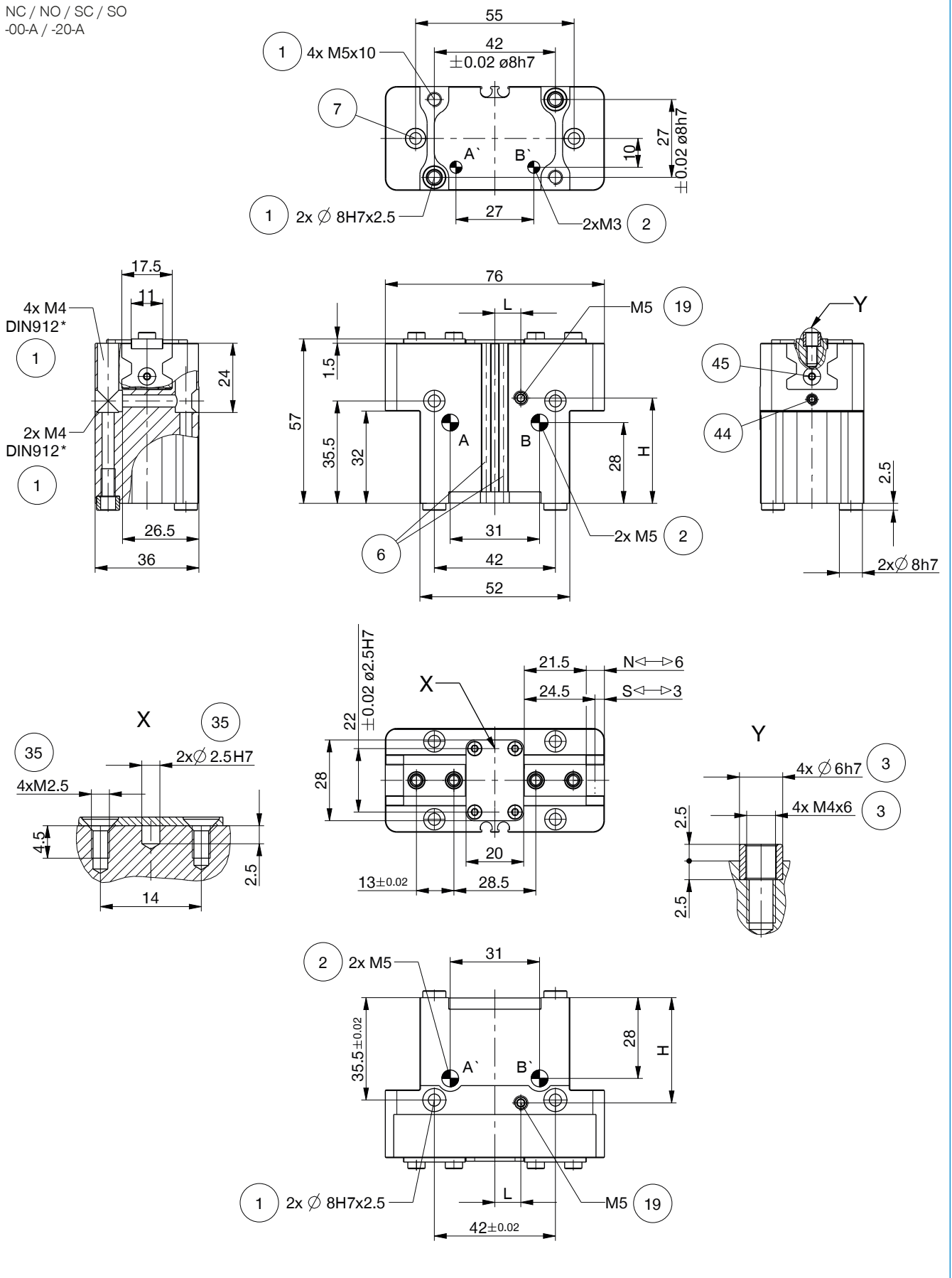

TECHNICAL DRAWINGS

N / S
-00-A / -20-A

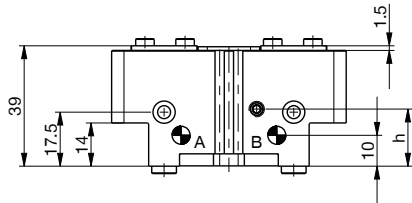

N / NC / NO / S / SC / SO
-21-A / -24-A

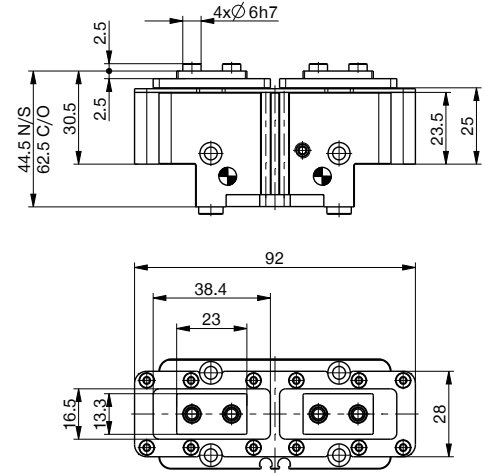

Hoseless air feed-through M3

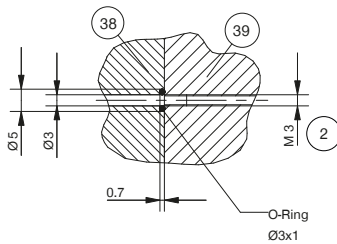

Hoseless air feed-through M5

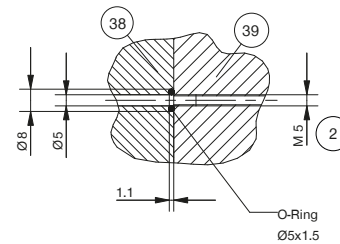

- ① Gripper attachment
- ② Energy supply
- ③ Fixing for gripper finger
- ⑥ Integrated slot for magnetic field sensor
- ⑦ Mounting block (not for variant AL-A)
- ⑰ Air purge connection option (max. 0,5 bar)
- ⑳ Attachment option for customer-specific fittings
- ㉔ Adapter
- ㉙ Gripper
- ④④ Clamping sensor (not for variant AL-A)
- ④⑤ Switch cam adjustment (not for variant AL-A)
- Ⓐ Air connection (close)
- Ⓑ Air connection (open)
- Ⓐ Air connection, alternative (close)
- Ⓑ Air connection, alternative (open)

► Position ⑰ sealing air connection option

GPP5006

Installation size	
H [mm]	36.5
L [mm]	9
h [mm]	18.5



2-JAW PARALLEL GRIPPERS

INSTALLATION SIZE GPP5006

▶ ACCESORIES

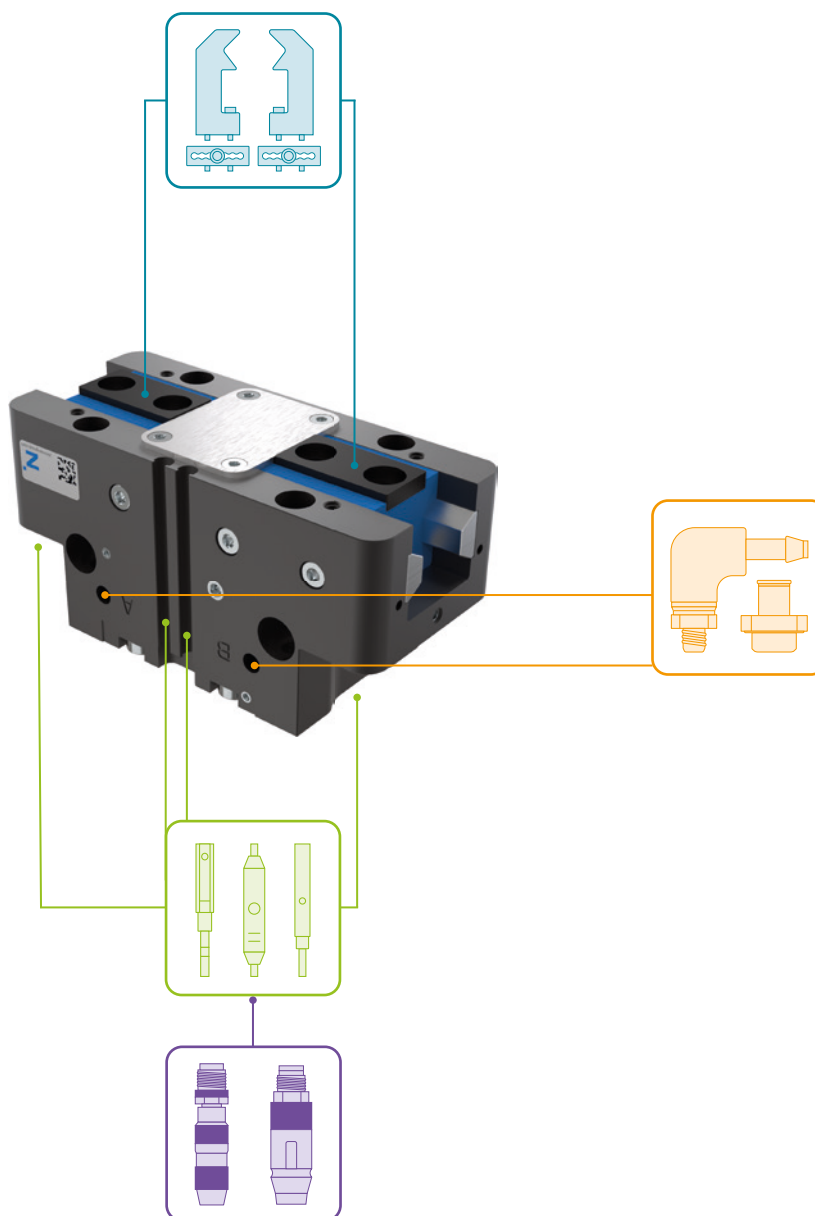

▶ INCLUDED IN DELIVERY



4 [piece]
Centering Disc

024230



2 [piece]
Centering Disc

024231

▶ RECOMMENDED ACCESSORIES



GRIPPING COMPONENTS

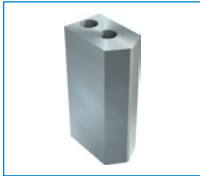

UB5006AL
Universal jaw aluminium



UB5006ST
Universal jaw steel



EB5006AL
Aluminum adjustment jaw



EB5006ST
Steel adjustment jaw

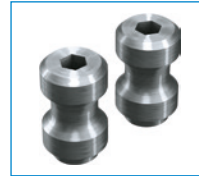

WB5006L
Changeable jaw, loose-part-set



WB5006F
Changeable jaw, fix-part



ENERGY SUPPLY



WVM5
Angled Fittings - Quick Connect Style



DSV1-8
Pressure safety valve



DSV1-8E
Pressure safety valve with quick exhaust



SENSORS



NJ4-E2SK-01
Inductive Proximity Switch
Cable 0,3 m - Connector M8



MFS01-S-KHC-P1-PNP
Magnetic field sensor angled,
cable 0.3 m - M8 connector



MFS02-S-KHC-P1-PNP
Magnetic field sensor straight,
cable 0.3 m - M8 connector

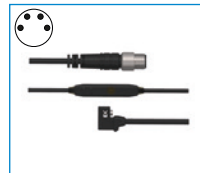

MFS01-S-KHC-P2-PNP
2-point sensor angled, ca-
ble 0.3 m - M8 connector



MFS02-S-KHC-P2-PNP
2-point sensor straight, ca-
ble 0.3 m - M8 connector

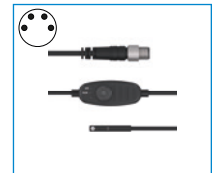

MFS02-S-KHC-IL
Straight position sensor,
cable 0.3 m - M8 plug



CONNECTIONS / OTHER

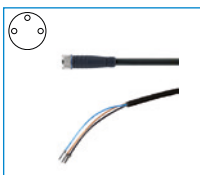

KAG500
Plug-in connector Straight Ca-
ble 5m - female connector M8

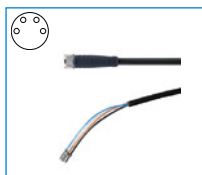

KAG500B4
Plug-in connector Straight Ca-
ble 5m - female connector M8



S8-G-4
Plug-in connector customizable
Straight - male connector M8

2-JAW PARALLEL GRIPPERS

SERIES GPP5000 FUNCTIONAL DESCRIPTION



GRIPPING COMPONENTS

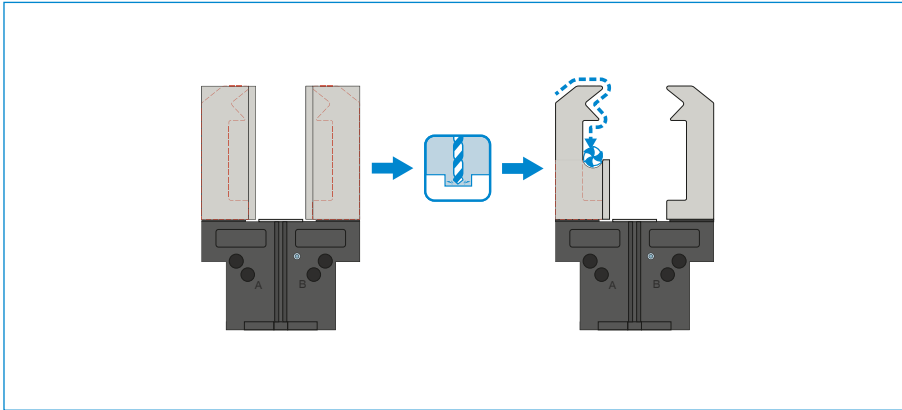

Universal jaws – UB5000

Can be used immediately or for individual reprocessing

The gripper blanks are available in aluminum (AL) and steel (ST) versions and are installed directly on the gripper using the screws in the scope of delivery. The fits for the centering sleeves are already in place for this purpose. One universal jaw is required for each gripper jaw.

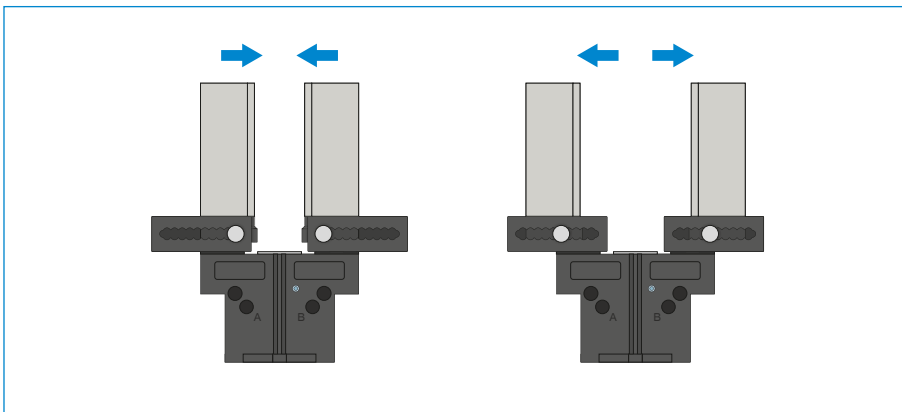

Adjustment jaws – EB5000

For tool-free adaptation of the gripper range

By manually activating the locking mechanism, which is pre-tensioned by a spring, the adjustment jaw can be moved within a grid of detent notches that has a number scale. Depending on the forces and torques that apply, the adjustment jaws are available in aluminum (AL) and steel (ST) versions. One adjustment jaw is required for each gripper jaw.

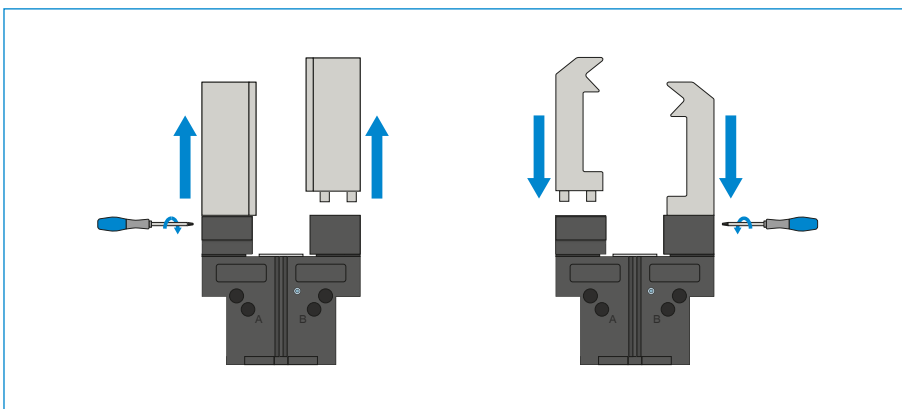

Interchangeable jaws – WB5000

Enable fast change of individual gripper fingers

For each gripper jaw, a fixed part and at least one loose part set is needed, depending on the number of gripper fingers to be changed. Manual locking via the Torx wrench included in the scope of delivery of the fixed part can take place from two sides.



THE GRIPPING COMPONENTS CAN BE COMBINED!

The gripper components listed above can be combined with each other and are compatible with the various series of the 5000 gripper family.



ENERGY SUPPLY

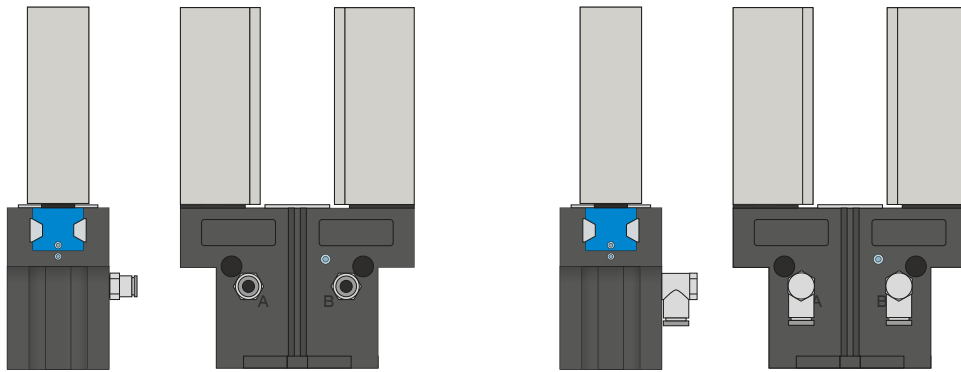

Pneumatic threaded connections

Available in straight and angled design. Can be chosen freely depending on the space conditions or installation situation.

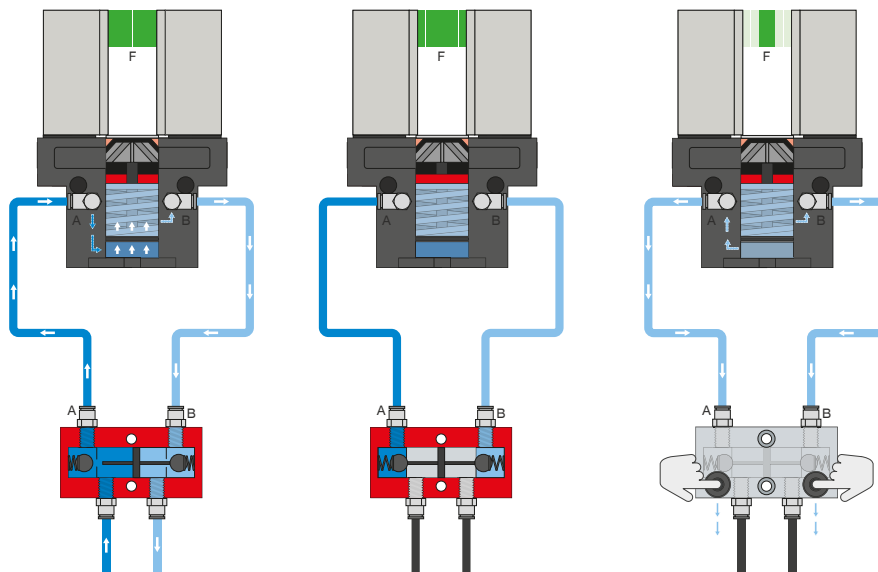

Pressure safety valve – DSV

Ensures safe retention of force and position if the system pressure drops

The integrated double check valve, which can be unlocked, retains the system pressure of the gripper in case of EMERGENCY STOP. To ensure the function, the valve must be installed as close to the gripper's air connection as possible. In variant E, two pushbuttons are installed that allow for controlled bleeding of the gripper.

2-JAW PARALLEL GRIPPERS

SERIES GPP5000 FUNCTIONAL DESCRIPTION



ENERGY SUPPLY

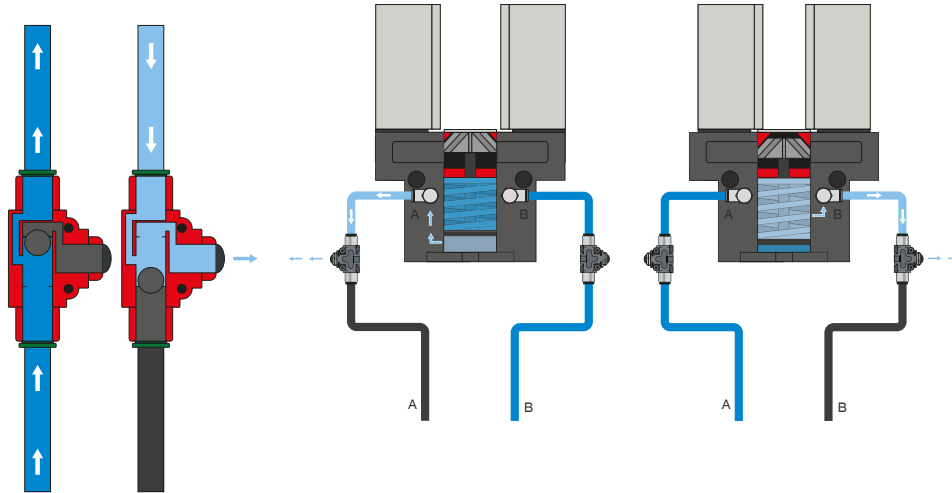

Quick exhaust valve – DEV

For rapid bleeding of the compressed air and preventing back pressure

The inline valves make a faster cycle time possible and prevent the formation of condensate in grippers with a small cylinder volume. To ensure the function, the valve must be installed as close to the gripper's air connection as possible.



SENSORS

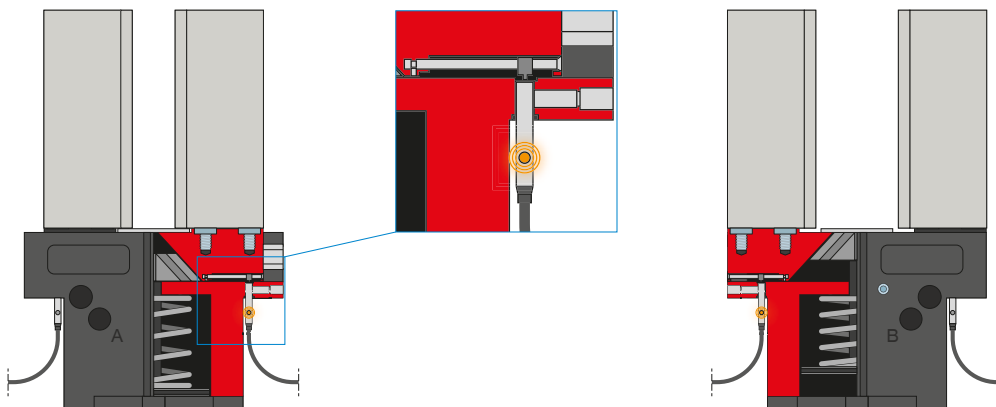

Inductive sensors – NJ

For direct position sensing of the gripper jaws

The sensor is guided into the intake as far as it will go and fixed in place using the lateral clamping screw. Tuning to the desired position then takes place by adjusting the cam switch. The sensors are available in versions with 5 m cables with exposed leads and 0,3 m cable with male connector, as well as with direct male connector orientation.



SENSORS

MFS02

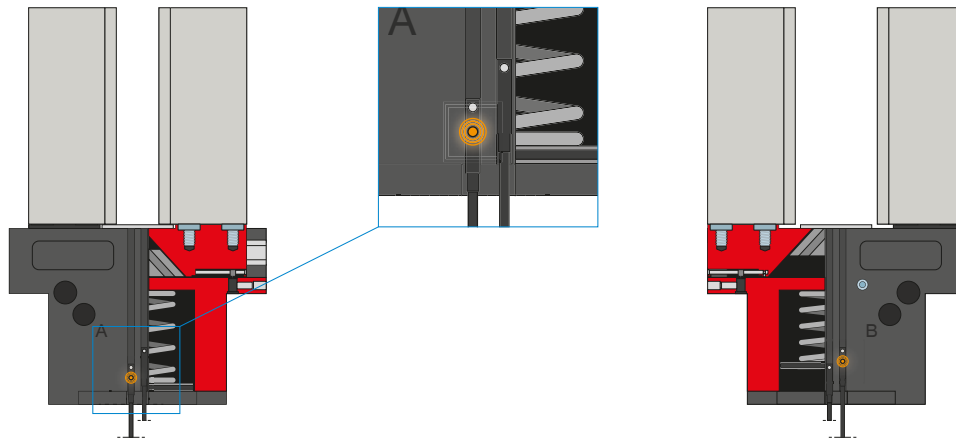

MFS01

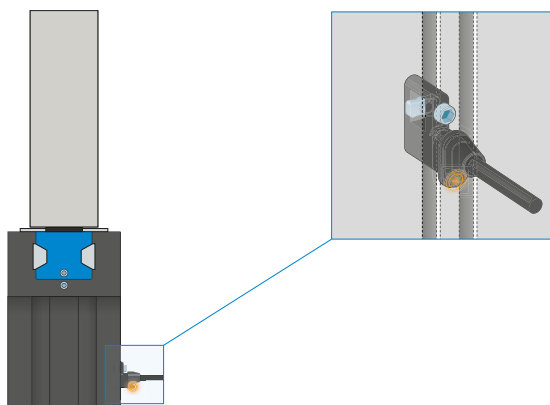

1-point magnetic field sensors – MFS

For non-contact sensing of the piston position

These sensors are installed in the C-groove of the gripper and detect the magnet attached to the piston of the gripper. To ensure use in a wide variety of space conditions, the sensors are available in two variants. While the horizontal MFS02, with straight cable outlet, disappears into the C-groove of the gripper almost completely, the vertical MFS01 is taller, but has a cable outlet that is offset at an angle of 90°. The variants are available in versions with 5 m cables with exposed leads and 0,3 m cable with connector.

2-JAW PARALLEL GRIPPERS

SERIES GPP5000 FUNCTIONAL DESCRIPTION



SENSORS

MFS02

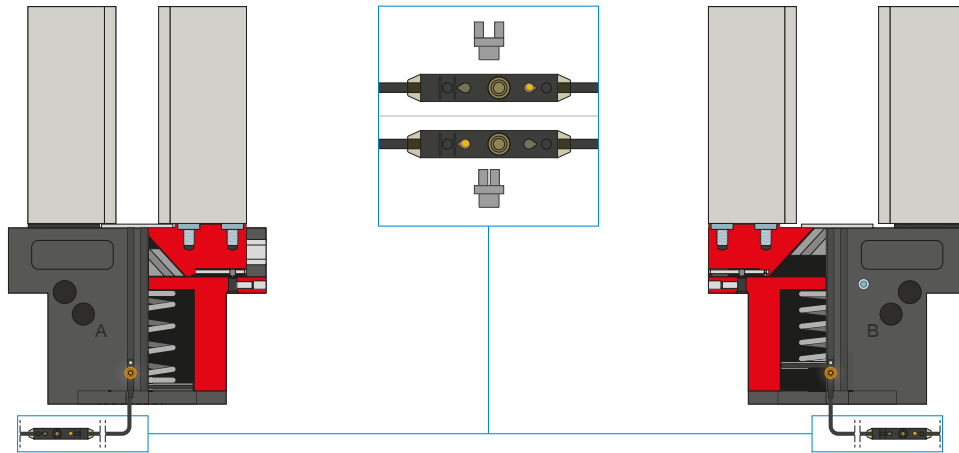

2-point magnetic field sensors - MFS

With two freely programmable switching points

Using the programming unit integrated in the cable, two switch points can be freely defined for this sensor. To do so, the sensor is clamped in the C-groove, the gripper approaches position one and the position is taught in using the teach button. Afterwards, the second position is approached with the gripper and programmed. To ensure use in a wide variety of space conditions, the sensors are available in two variants. While the horizontal MFS02, with straight cable outlet, disappears into the C-groove of the gripper almost completely, the vertical MFS01 is taller, but has a cable outlet that is offset at an angle of 90°. The sensors are available in versions with 5 m cables with exposed leads and 0,3 m cable with connector.



CONNECTIONS / OTHER



Plug-in connectors

For extending and fabricating the connection lines for the sensors

Cables with a length of 5 m with exposed leads are available. Depending on the specific needs, the cables can be shortened or fabricated with connectors in sizes M8 and M12.



CONNECTIONS / OTHER

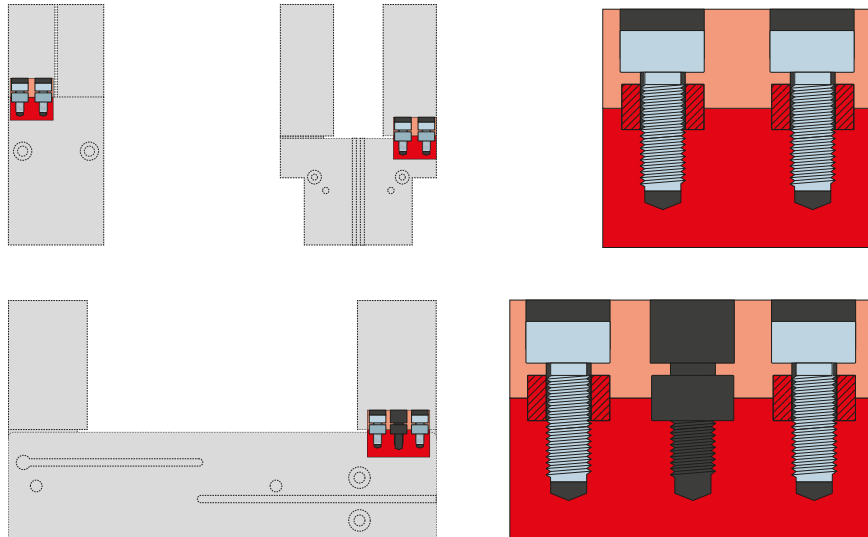

Centering sleeves

For defined position measurement of the gripper fingers

The centering sleeves are inserted into the fits of the gripper jaws to define the position of the gripper fingers. The centering sleeves are comparable to a pin connection.

2-JAW PARALLEL GRIPPERS

SERIES GPP5000 GRIPPER FINGER LENGTH



MAXIMUM GRIPPER FINGER LENGTH

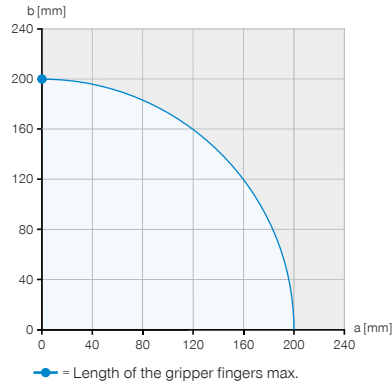
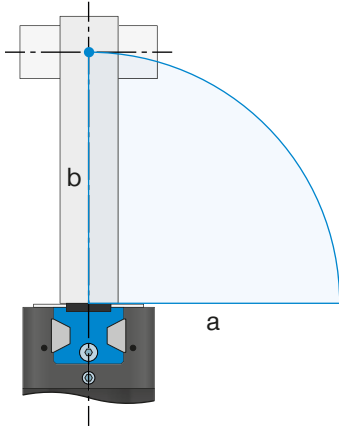

Example 1

Vertical force application point

$a = 0 \text{ mm}$

$b = 200 \text{ mm}$

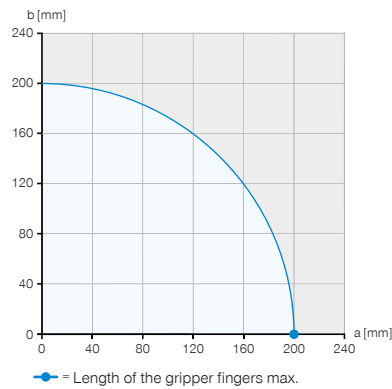
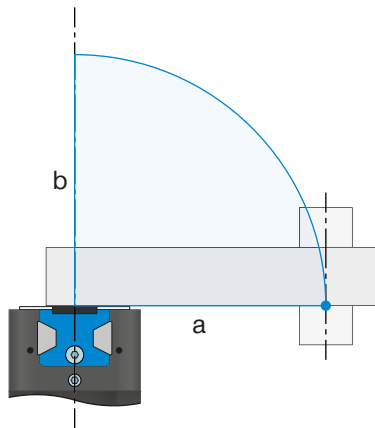

Example 2

Horizontal force application point

$a = 200 \text{ mm}$

$b = 0 \text{ mm}$

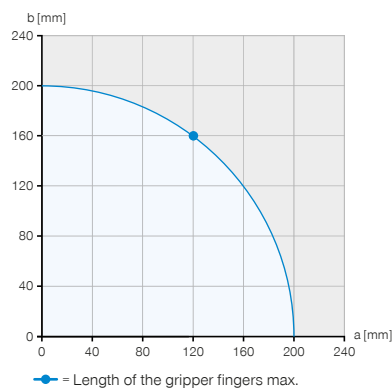
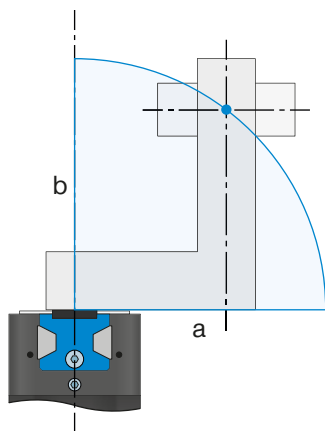

Example 3

Maximum permissible projection

$a = 120 \text{ mm}$

$b = 160 \text{ mm}$

The examples show the maximum horizontal (a) and vertical (b) gripper finger length using the example of a GPP5013N-00-A, which is represented by the blue area.



GRIPPING FORCE AS A FUNCTION OF GRIPPER FINGER LENGTH

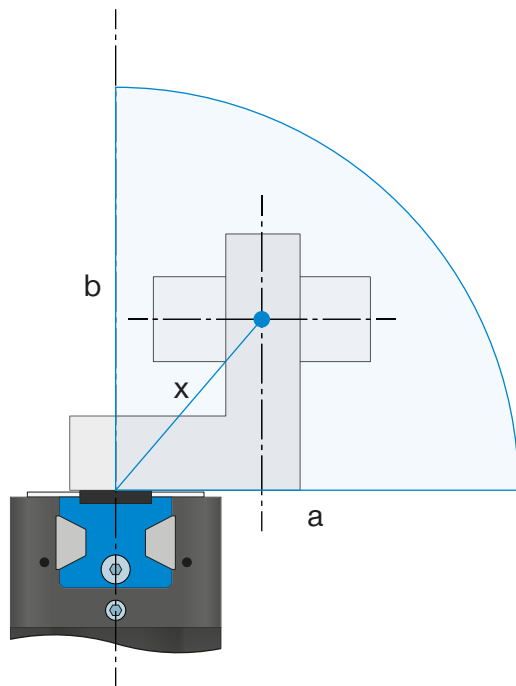

► Gripping force diagram

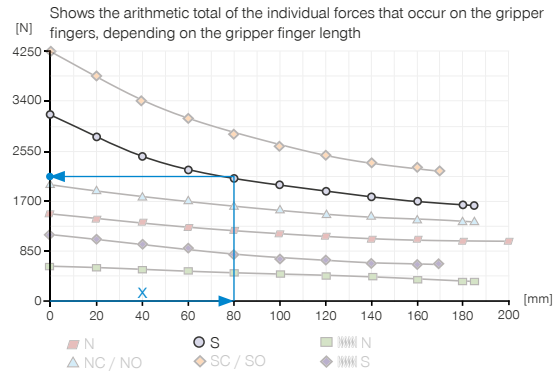

Example 4

Resulting gripper finger length for determining the gripping force

a = 55 mm

b = 58 mm

$$x = \sqrt{55^2 + 58^2} = 80 \Rightarrow 2125 \text{ N}$$



GUIDE CHARACTERISTICS

Steel / aluminum guide and steel / steel guide in comparison

In general, the maximum possible length of gripper fingers of a steel / aluminum guide is lower in comparison to the steel / steel guide, due to the lower yield point of aluminum. While the maximum gripper finger length in the horizontal (a) and vertical (b) direction can be fully utilized for the steel / steel guide, the maximum gripper finger length that is specified in the technical data for the steel / aluminum guide is reduced by 20% at a horizontal (a) projection. The lower efficiency of a steel / aluminum guide also leads to a higher decrease in gripping force at an increased gripping finger length and to a reduction in service life as a result of a lower resistance to wear.

Steel / aluminum guide

Steel / aluminum guides are very common worldwide. They are available in many different forms and are installed in virtually all commercially available grippers from an extremely wide variety of manufacturers. The steel / aluminum grippers from Zimmer Group are available as AL variants of the tried-and-tested 5000 Series. Their designs are geared toward the important aspects and they are very cost-effective.

Steel / steel guide

Steel / steel guides are the best and first choice wherever durability and robustness are essential. The Steel Linear Guide from Zimmer Group is also clearly distinguished from a steel / aluminum guide thanks to its exclusive design featuring higher material characteristics.

Steel Linear Guide – Added value in detail

- + Steel in steel guide
- + IP64 and up to IP67 (with sealing air) in the protector version
- + Corrosion protected
- + Up to 30 million maintenance-free cycles (max.)