

BECKHOFF New Automation Technology

Operating instructions | EN

AX8000

Multi-axis servo system

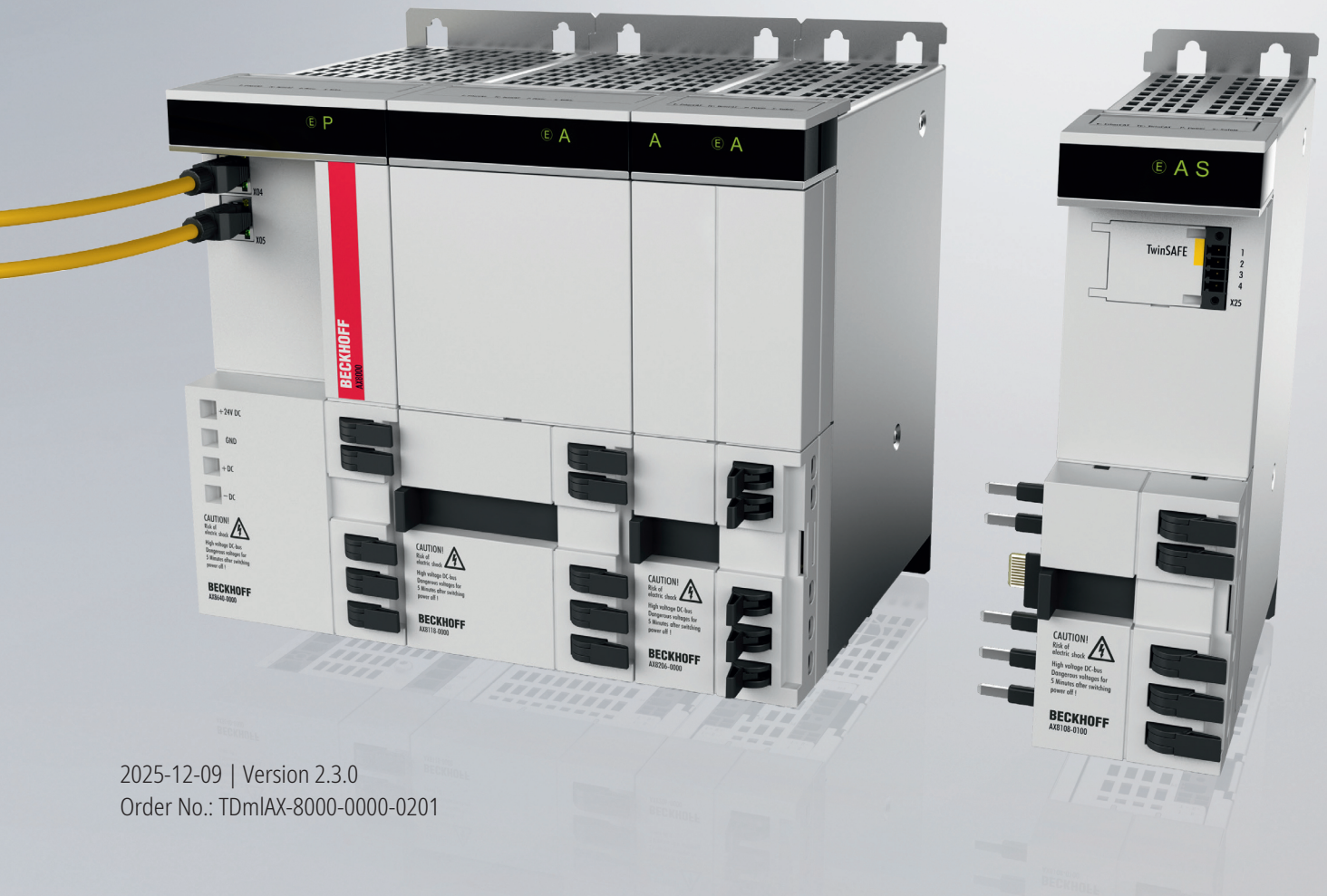

2025-12-09 | Version 2.3.0

Order No.: TDmlAX-8000-0000-0201

Table of contents

1	Documentation notes	7
1.1	Disclaimer	7
1.1.1	Trademarks	7
1.1.2	Limitation of liability	7
1.1.3	Copyright	8
1.1.4	Third-party brands	8
1.2	Version numbers	9
1.3	Scope of the documentation	9
1.4	Staff qualification	10
1.5	Safety and instruction	11
1.5.1	Notes on information security	11
1.6	Explanation of symbols	12
1.7	Beckhoff Services	14
1.7.1	Support services	14
1.7.2	Training offerings	14
1.7.3	Service offerings	14
1.7.4	Headquarters Germany	15
1.7.5	Downloadfinder	15
2	For your safety	16
2.1	Safety pictograms	16
2.2	General safety instructions	17
2.2.1	Before operation	17
2.2.2	During operation	18
2.2.3	After operation	18
3	Product overview	19
3.1	Power supply module AX86xx	19
3.1.1	Name plate AX8600	20
3.1.2	AX8620, AX8640 name plate	21
3.1.3	Type key AX86xx	22
3.2	Axis modules AX81xx, AX82xx	23
3.2.1	Name plate AX81xx, AX82xx	25
3.2.2	Type key AX81xx, AX82xx	26
3.3	Combined modules AX85xx	27
3.3.1	Name plate AX85xx	29
3.3.2	Type key AX85xx	30
3.4	AX8810 capacitor module	31
3.4.1	Name plate AX8810	31
3.4.2	Type key AX8810	32
3.5	Product characteristics	33
3.6	Ordering options	35
3.6.1	TwinSAFE Drive-integrated safety technology	35
3.6.2	Multi-feedback interface	36
3.7	Intended use	38
3.7.1	Improper use	38

3.8	Dual Use	39
4	Technical data	41
4.1	Data for operation and environment.....	41
4.2	Power supply module AX86xx	43
4.2.1	DC power supply module AX8600	43
4.2.2	Power supply module AX8620 (20 A)	44
4.2.3	Power supply module AX8640 (40 A)	46
4.3	Axis modules AX81x8, AX8206	47
4.3.1	1-channel axis modules AX8108, AX8118, AX8128	47
4.3.2	2-channel axis module AX8206.....	50
4.4	Combined power supply modules and axis modules AX8525, AX8540	52
4.5	AX8810 capacitor module	54
4.6	Dimensional drawings	55
4.6.1	Narrow modules (AX8108, AX8206, AX8600, AX8620, AX8810).....	55
4.6.2	Wide modules (AX8118, AX8128, AX8640).....	57
4.6.3	Combined modules (AX8525, AX8540)	58
5	Scope of supply.....	59
5.1	Packaging	60
6	Transport and storage	61
6.1	Conditions	61
6.2	Transport.....	62
6.3	Long-term storage.....	62
7	Technical description	63
7.1	Installation position.....	63
7.2	Residual current circuit breaker	63
7.3	Safe system stop	63
7.4	Wide voltage range of the power supply	64
7.5	Dimensioning	65
7.5.1	DC link capacitance.....	65
7.5.2	Total motor cable length.....	67
7.5.3	Control voltage	69
7.6	Display	70
7.6.1	Power supply module	70
7.6.2	Axis module.....	72
7.6.3	Combined module	73
7.7	AX8810 capacitor module	74
7.7.1	Placement in the group	74
7.8	AX8600 Power supply module DC.....	75
7.9	ZK4875-900x DC link connection cable	77
7.10	Third-party motors.....	77
7.11	TwinSAFE safe drive technology	78
7.11.1	Beckhoff synchronous servomotors	79
7.11.2	Beckhoff linear servomotors.....	80
7.11.3	Third-party motors and TwinSAFE	81
7.12	Forming the capacitors.....	81

8 Mechanical installation	82
8.1 Preparation.....	82
8.1.1 Drilling pattern	84
8.2 Modules.....	84
8.2.1 Power supply modules	84
8.2.2 Axis modules and capacitor modules.....	85
9 Electrical installation	87
9.1 Project planning	87
9.1.1 Energy management.....	88
9.1.2 Control cabinet structure	88
9.1.3 Drivetrain	88
9.2 Block diagrams.....	89
9.2.1 AX8600 DC Power supply module	89
9.2.2 AX8620 Power supply module 20 A.....	90
9.2.3 AX8640 Power supply module 40 A.....	91
9.2.4 AX85xx combined power supply modules and axis modules 25 A, 40 A.....	92
9.2.5 AX81x8 single-axis module 8 A, 18 A, 28 A.....	93
9.2.6 AX8206 Dual-axis module 6 A	94
9.3 Grounding	95
9.3.1 Module connection	95
9.3.2 Protective earth	97
9.4 Connector power supply 24 V.....	98
9.4.1 ZS4800-2001 Connector power supply module AX8620	98
9.4.2 ZS4800-2002 Connector power supply module AX8600	98
9.4.3 ZS4800-2003 Connector combined modules AX85xx	99
9.4.4 ZS4800-2042 Connector power supply module AX8640	99
9.5 Connector voltage input	100
9.5.1 ZS4800-2001 Connector power supply module AX8620	100
9.5.2 ZS4800-2002 Connector power supply module AX8600	100
9.5.3 ZS4800-2041 Connector power supply module AX8640	101
9.5.4 Terminal strip on AX85xx	101
9.6 Connector external brake resistor	102
9.6.1 ZS4800-2001 Connector power supply module AX8620	102
9.6.2 ZS4800-2002 Connector combined modules AX8600	102
9.6.3 ZS4800-2042 Connector power supply module AX8640	103
9.6.4 ZS4500-2047 Connector combined modules AX85xx	103
9.7 DC link.....	104
9.7.1 Terminal strip.....	104
9.8 Fieldbus system	104
9.9 Multi-feedback interface	105
9.9.1 Cables and connection of the cable	105
9.9.2 AX81xx-0x10 with 2 x D-sub	107
9.9.3 AX81xx-0x20 with 1 x D-sub	108
9.9.4 AX82xx-0x10 with 2 x D-sub	109
9.9.5 AX85xx-0x20 with 1 x D-sub	110
9.10 Motor feedback OCT.....	111

Table of contents

9.10.1	ZS4800-2013 / Connector plug for AX8108 / AX8118 / AX8206 axis modules.....	111
9.11	AX8128, AX8525, and AX8540 motor connector.....	112
9.11.1	ZS4800-2043 / AX8128 connector plug and AX85xx combined modules.....	112
9.12	Holding brake / OCT / temperature sensor.....	113
9.12.1	ZS4500-2014 / AX8128 connector plug and AX85xx combined modules.....	113
9.13	Digital inputs.....	114
9.13.1	ZS4800-2015 I/O connector plug.....	114
9.13.2	Modules without TwinSAFE.....	114
9.13.3	Modules with TwinSAFE.....	115
9.14	Leakage currents.....	116
9.15	Supply networks.....	117
9.15.1	Three-phase connection.....	118
9.15.2	Single-phase connection.....	120
9.15.3	Isolating transformers.....	124
9.16	Fuse protection.....	125
9.16.1	CE conform.....	125
9.16.2	UL-compliant.....	127
9.16.3	Device fusing.....	129
10	Commissioning.....	131
10.1	Before commissioning.....	131
10.1.1	Voltage testing and insulation resistance measurement.....	131
10.2	During commissioning.....	132
10.3	Prerequisites during operation.....	132
10.4	After operation.....	132
11	Maintenance and cleaning.....	133
11.1	Intervals.....	133
12	Accessories.....	134
12.1	Brake resistor.....	134
12.2	Braking resistor IP65.....	134
12.3	Mains choke.....	134
12.4	Mains filter.....	135
13	Decommissioning.....	136
13.1	Disassembly.....	136
13.2	Disposal.....	137
14	Guidelines and Standards.....	138
14.1	Standards.....	138
14.2	Guidelines.....	139
14.2.1	Electrical isolation.....	139
14.3	Test centers.....	140
14.4	EU conformity.....	140
14.5	UL certification.....	141
14.5.1	USA and Canada.....	141
	Index.....	142
15	Notes.....	143

1 Documentation notes

1.1 Disclaimer

Beckhoff products are subject to continuous further development. We reserve the right to revise the documentation at any time and without notice. No claims for the modification of products that have already been supplied may be made on the basis of the data, diagrams, and descriptions in this documentation.

This product contains software.

The relevant legal information and licenses can be found in the internal memory of this product or in the open source software declarations in the download area of the product on the Beckhoff website at

 www.beckhoff.com/en-en/products/

You can also send an e-mail to the address below for further information.

 osscompliance@beckhoff.com

By using the product, you agree to the relevant licenses for the software included in the product.

1.1.1 Trademarks

Beckhoff®, ATRO®, EtherCAT®, EtherCAT G®, EtherCAT G10®, EtherCAT P®, MX-System®, Safety over EtherCAT®, TC/BSD®, TwinCAT®, TwinCAT/BSD®, TwinSAFE®, XFC®, XPlanar®, and XTS® are registered and licensed trademarks of Beckhoff Automation GmbH.

The use by third parties of other brand names or trademarks contained in this documentation may lead to an infringement of the rights of the respective trademark owner.



EtherCAT® is a registered trademark and patented technology, licensed by Beckhoff Automation GmbH.

1.1.2 Limitation of liability

All components of this product described in the original operating instructions are delivered in a hardware and software configuration, depending on the application requirements. Modifications and changes to the hardware or software configuration that go beyond the documented options are prohibited and nullify the liability of Beckhoff Automation GmbH & Co. KG.

The following is excluded from the liability:

- Failure to comply with this documentation
- Improper use
- Use of untrained personnel
- Use of unauthorized spare parts

1.1.3 Copyright

© Beckhoff Automation GmbH & Co. KG, Germany

The copying, distribution and utilization of this document as well as the communication of its contents to others without express authorization is prohibited. Offenders will be held liable for the payment of damages.

We reserve all rights in the event of registration of patents, utility models and designs.

1.1.4 Third-party brands

Third-party trademarks and wordmarks are used in this documentation. The corresponding trademark endorsements can be found at

 www.beckhoff.com/trademarks

1.2 Version numbers

On request we can send you a list of revision levels for changes to the documentation. Please send your request to:

✉ motion-documentation@beckhoff.com

Origin of the document

This documentation was originally written in German. All other languages are derived from the German original.

Product features

The valid product features are always those specified in the current documentation. Further information given on the product pages of the Beckhoff homepage, in emails or in other publications is not authoritative.

1.3 Scope of the documentation

Apart from these operating instructions, the following documents are part of the overall documentation:

Documentation	Definition
AX8000 Functional description	Documentation of the various functions of the AX8000 multi-axis servo system
AX8620, AX8640, AX8525 and AX8540 Power supply module Object description	Operating instructions with short descriptions and attribute tables of the power supply modules of the AX8000 multi-axis servo system
AX8620, AX8640, AX8525 and AX8540 Power supply module Diagnosis messages	Documentation of the error messages of the AX8000 multi-axis servo system with attribute tables, problem descriptions and possible solutions
AX8xxx Object description for axis module	Operating instructions with short descriptions and attribute tables for the axis modules of the AX8000 multi-axis servo system
AX8xxx Diagnostic messages for axis module	Documentation of the error messages of the AX8000 multi-axis servo system with attribute tables, problem descriptions and possible solutions
AX2090-BW80 braking resistors	Operating instructions for the use and installation of the AX2090-BW80 braking resistors as accessories for the AX8000 multi-axis servo system
AX2090-BW65 braking resistors IP65	Operating instructions for the use and installation of the AX2090-BW65 braking resistors with the protection rating IP65 as accessories for the AX8000 multi-axis servo system

Documentation	Definition
AX2090-ND80 mains chokes	Operating instructions for the use and installation of the AX2090-ND80 mains chokes as accessories for the AX8000 multi-axis servo system
AX2090-TT80 isolating transformers	Data sheet with mechanical and electrical data as well as initial information on the use of the AX2090-TT80 isolating transformers as accessories for the AX8000 multi-axis servo system
Mains filters AX2090-NF80	Operating instructions for the use and installation of the AX2090-NF80 mains filter as accessories for the AX8000 multi-axis servo system

1.4 Staff qualification

This documentation is aimed at trained specialists working in control technology and automation who have knowledge of the applicable and required standards and directives.

Specialists must have knowledge of drive technology and electrical equipment as well as knowledge of safe working on electrical systems and machines. This includes knowledge of proper setup and preparation of the workplace as well as securing the working environment for other persons.

The documentation published at the time must be used for each installation and commissioning. The products must be used in compliance with all safety requirements, including all applicable laws, regulations, provisions and standards.

Instructed person

Instructed persons have a clearly defined task area and have been informed about the work to be carried out. Instructed persons are familiar with:

- the necessary protective measures and protective devices
- the intended use and risks that can arise from use other than for the intended purpose

Trained person

Trained persons meet the requirements for instructed persons. Trained persons have additionally received training from the machine builder or vendor:

- machine-specific or
- plant-specific

Trained specialists

Trained specialists have received specific technical training and have specific technical knowledge and experience. Trained specialists can:

- apply relevant standards and directives
- assess tasks that they have been assigned
- recognize possible hazards
- prepare and set up workplaces

Electricians

Electricians have extensive technical knowledge from their studies, apprenticeships, or specialist training. They have an understanding of control technology and automation. They are familiar with relevant standards and directives. Electricians can:

- independently recognize, avoid and eliminate sources of danger
- implement specifications from the accident prevention regulations
- assess the work environment
- independently optimize and carry out their work

1.5 Safety and instruction

Read the contents that are related to the activities you will perform with the product. Always read the "For your safety", [Page 16] chapter in the documentation. Observe the warning notes in the chapters so that you can handle the product and work with it properly and safely.

1.5.1 Notes on information security

The products of Beckhoff Automation GmbH & Co. KG (Beckhoff), insofar as they can be accessed online, are equipped with security functions that support the secure operation of plants, systems, machines and networks. Despite the security functions, the creation, implementation and constant updating of a holistic security concept for the operation are necessary to protect the respective plant, system, machine and networks against cyber threats. The products sold by Beckhoff are only part of the overall security concept. The customer is responsible for preventing unauthorized access by third parties to its equipment, systems, machines and networks. The latter should be connected to the corporate network or the Internet only if appropriate protective measures have been set up.

In addition, the recommendations from Beckhoff regarding appropriate protective measures should be observed. Further information regarding information security and industrial security can be found in our <https://www.beckhoff.com/secguide>.

Beckhoff products and solutions undergo continuous further development. This also applies to security functions. In light of this continuous further development, Beckhoff expressly recommends that the products are kept up to date at all times and that updates are installed for the products once they have been made available. Using outdated or unsupported product versions can increase the risk of cyber threats.

To stay informed about information security for Beckhoff products, subscribe to the RSS feed at <https://www.beckhoff.com/secinfo>.

1.6 Explanation of symbols

Various symbols are used for a clear arrangement:

- ▶ The triangle indicates instructions that you should execute.
- The bullet point indicates an enumeration.
- [...] The square brackets indicate cross-references to other text passages in the document.
- [1] The number in the square brackets refers to the position in the adjacent figure.
- [+] The plus sign in square brackets indicates ordering options and accessories.

In order to make it easier for you to find text passages, pictograms and signal words are used in warning notices:

DANGER

Failure to comply will result in serious or fatal injuries.

WARNING

Failure to comply may result in serious or fatal injuries.

CAUTION

Failure to comply may result in minor or moderate injuries.

NOTICE

Notes are used for important information on the product. The possible consequences of failure to observe these include:

- product malfunctions
- damage to the product
- damage to the environment



Information

This symbol indicates information, tips, and notes for handling the product or the software.



Examples

This symbol shows examples of how to use the product or software.



Required tool

This symbol indicates a tool that is required for the following steps.



Required accessories [+]

This symbol shows the accessories required for the following steps. The accessories are not included in the scope of delivery and can be ordered from Beckhoff.



Assembly material required

This symbol shows the assembly material required for the following steps. The assembly material is not included in the scope of delivery and must be purchased separately.



Permitted cleaning agents

This symbol indicates the permitted cleaning agents that the components may be cleaned with. The permitted cleaning agents are not included in the scope of delivery and must be purchased separately.



QR codes

This symbol shows a QR code that you can scan to watch videos or animations. Internet access is required in order to use it.

1.7 Beckhoff Services

Beckhoff and its international partner companies offer comprehensive support and service.

 www.beckhoff.com/en-en/support/global-availability/

1.7.1 Support services

The Beckhoff Support offers technical advice on the use of individual Beckhoff products and system planning. The support engineers offer you competent assistance, for comprehension questions as well as for commissioning.

 +49 5246 963-157

 support@beckhoff.com

 www.beckhoff.com/en-en/support/our-support-services/

1.7.2 Training offerings

Training in Germany takes place at the Beckhoff branches or, after consultation, at the customer's premises. Beckhoff offers both face-to-face and online training courses.

 +49 5246 963-5000

 training@beckhoff.com

 www.beckhoff.com/en-en/support/training-offerings/

1.7.3 Service offerings

The Beckhoff service experts support you worldwide in all areas of after-sales service.

 +49 5246 963-460

 service@beckhoff.com

 www.beckhoff.com/en-en/support/our-service-offerings/

1.7.4 Headquarters Germany

Beckhoff Automation GmbH & Co. KG
Hülshorstweg 20
33415 Verl, Germany

 +49 5246 963-0

 info@beckhoff.com

 www.beckhoff.com/en-en/

A detailed overview of the Beckhoff locations worldwide can be found at:

 www.beckhoff.com/en-en/company/global-presence/

1.7.5 Downloadfinder

In the Download finder you will find configuration files, technical documentation and application reports to download.

 www.beckhoff.com/documentations

2 For your safety

Read this chapter containing general safety information. The chapters in these operating instructions also contain warning notices. Always observe the safety instructions for your own safety, the safety of other persons and the safety of the product.

When working with control and automation products, many dangers can result from careless or incorrect use. Work particularly thoroughly, not under time pressure and responsibly towards other people.

2.1 Safety pictograms

You will find safety symbols on Beckhoff products and packaging. The symbols may be glued, printed, or lasered on and may vary depending on the product. They serve to protect people and to prevent damage to the products. Safety pictograms may not be removed and must be legible for the user.



Warning of high voltage!

The DC link capacitors and test contacts on all modules may carry hazardous voltages up to 848 V_{DC}.

2.2 General safety instructions

This chapter provides you with instructions on safety when handling the product. This product is not capable of stand-alone operation and is therefore categorized as an incomplete machine. The product must be installed in a machine or plant by the machine manufacturer. Read the documentation prepared by the machine manufacturer.

2.2.1 Before operation

Protective equipment

Do not remove or bypass any protective devices. Check all protective devices before operation. Make sure that all emergency switches are present at all times and can be reached by you and other people. People could be seriously or fatally injured by unprotected machine parts.

Shut down and secure the machine or plant

Shut down the machine or plant. Secure the machine or plant against being inadvertently started up.

Correctly ground electrical components or modules

Prevent electric shocks due to incorrect grounding of electrical components or modules. Ground all conductive components according to the specifications in the chapter "Electrical installation", [Page 87].

Keep the immediate environment clean

Keep your workplace and the surrounding area clean. Ensure safe working.

Check safety pictograms

Check whether the designated pictograms are on the product. Replace missing or illegible stickers.

Observe tightening torques

Mount and repeatedly check connections and components, complying with the prescribed tightening torques.

Use the original packaging only

When shipping, transporting, storing and packing, use the original packaging or non-conductive materials.

2.2.2 During operation

Observe the discharge times of the capacitors

Observe the following delay times after disconnecting from the mains supply:

- AX8600, AX8620, and AX8640 **30 minutes**
- AX8108, AX8118, AX8128, and AX8206 **30 minutes**
- AX8525 and AX8540 **30 minutes**

Note: In the power supply module the control word can be set to "Fast discharge DC link" in object 0x8000:11. This can trigger a rapid discharge of the DC link when the mains voltage is switched off. This allows the waiting time to be bypassed. Please note the general conditions of the object.

Do not work on live electrical parts

Do not open the multi-axis servo system while it is live. Measure the voltage on the DC link test contacts DC+ und DC-. Only work on the multi-axis servo system when the voltage has dropped to < 50 V. Ensure that the protective conductor is connected properly. Never loosen electrical connections when live. Disconnect all components from the mains and secure them against being switched on again.

Do not touch hot surfaces

Check the temperature of the surfaces with a thermometer. Do not touch the components during and immediately after operation. Allow the components to cool sufficiently after switching off.

Avoid overheating

Operate the components according to the technical specifications. Refer here to the chapter "Technical data", [Page 41]. Provide for sufficient cooling. Switch the components off immediately if the temperature is too high.

2.2.3 After operation

De-energize and switch off components before working on them

Check the functionality of all safety-relevant devices. Secure the working environment. Secure the machine or plant against being inadvertently started up. Observe the chapter "Decommissioning", [Page 136].

No direct skin contact with solvents or lubricants

In case of improper use, the solvents or lubricants used can lead to skin irritations. Avoid direct skin contact.

3 Product overview

3.1 Power supply module AX86xx

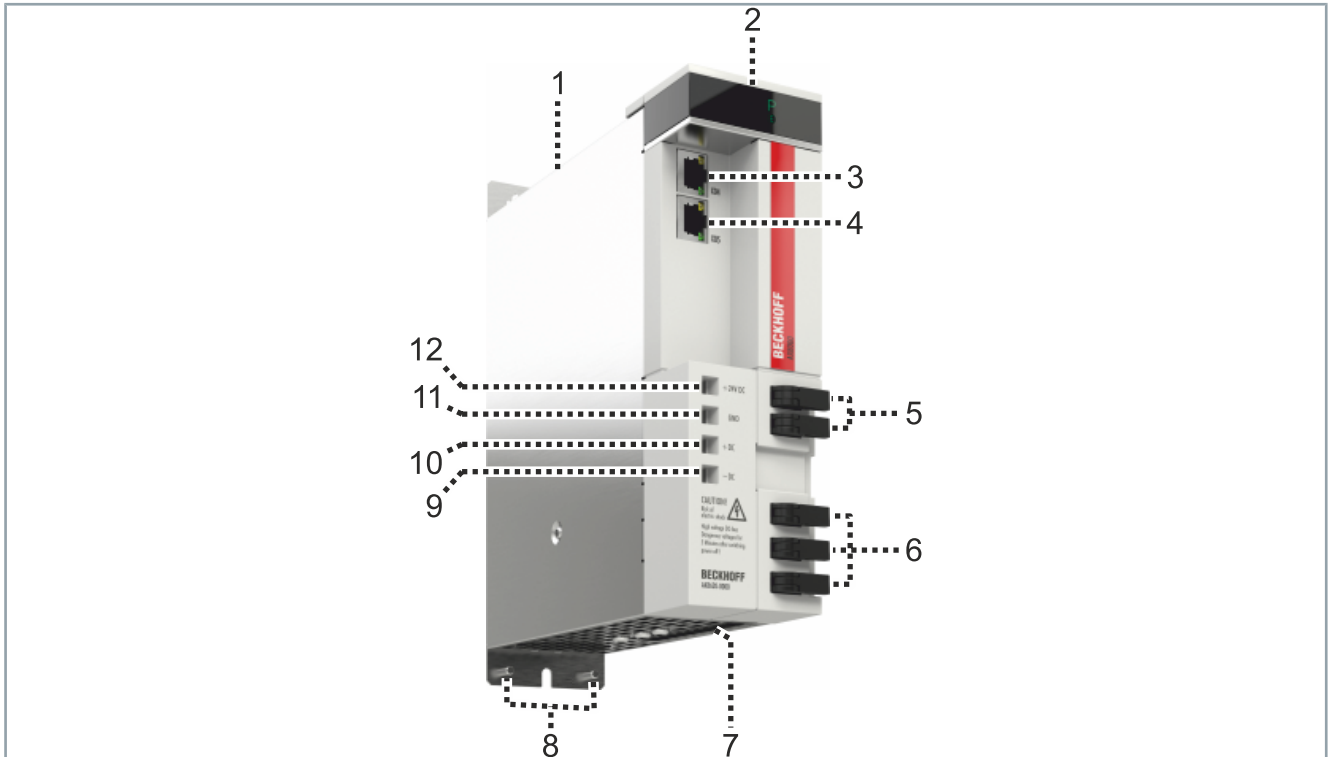

Item number	AX8600	AX8620	AX8640
1	Housing		
2	Display		
3	Fieldbus EtherCAT input X04		
4	Fieldbus EtherCAT output X05		
5	Quick coupling 24 V _{DC} ; AX bridge		
6	Quick coupling, DC link and protective earth PE; AX bridge		
7	Input terminal X01 7-pin; 24 V _{DC} , DC mains, PE and external braking resistor	Input terminal X01 10-pin; 24 V _{DC} , AC mains, PE and external braking resistor	Input terminal X01 4-pin; AC mains, PE
			Input terminal X02 6-pin; 24 V _{DC} , PE and external braking resistor
8	Grounding bolt		
9	Test contact DC link DC-		
10	Test contact DC link DC+		
11	Test contact GND		
12	Test contact +24 V _{DC}		

Product overview

3.1.1 Name plate AX8600

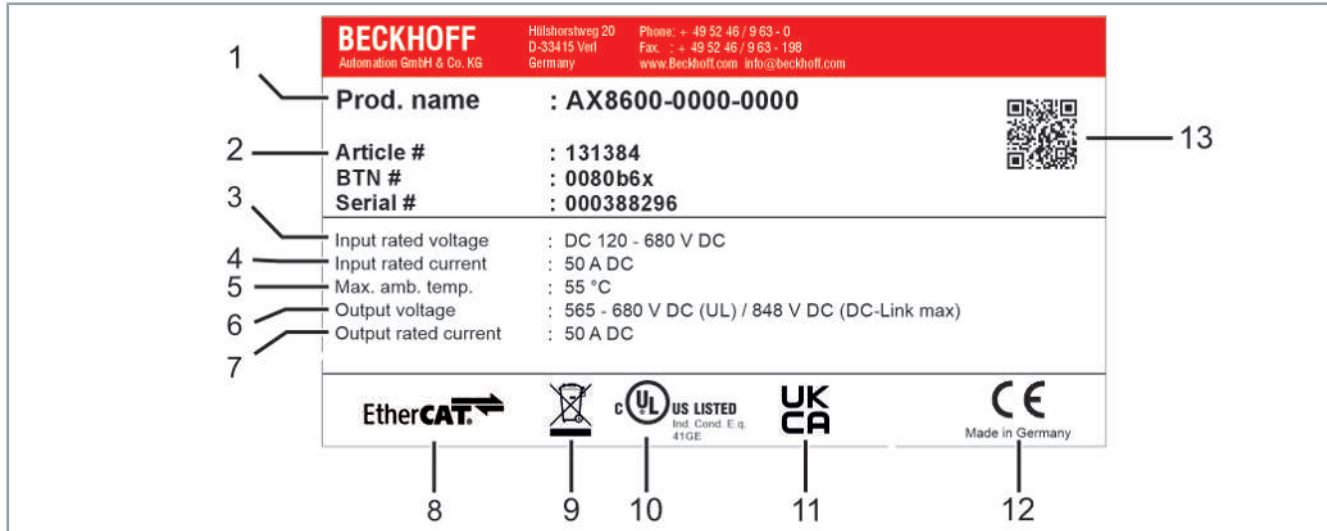

Item number	Explanation
1	Order number
2	Order number Beckhoff Traceability Number Serial number
3	Input rated voltage
4	Input rated current
5	Maximum ambient temperature
6	Output rated voltage
7	Output rated current
8	EtherCAT conformity
9	Disposal according to WEEE directive
10	cULus approval
11	UKCA conformity
12	CE approval
13	Data Matrix Code

3.1.2 AX8620, AX8640 name plate

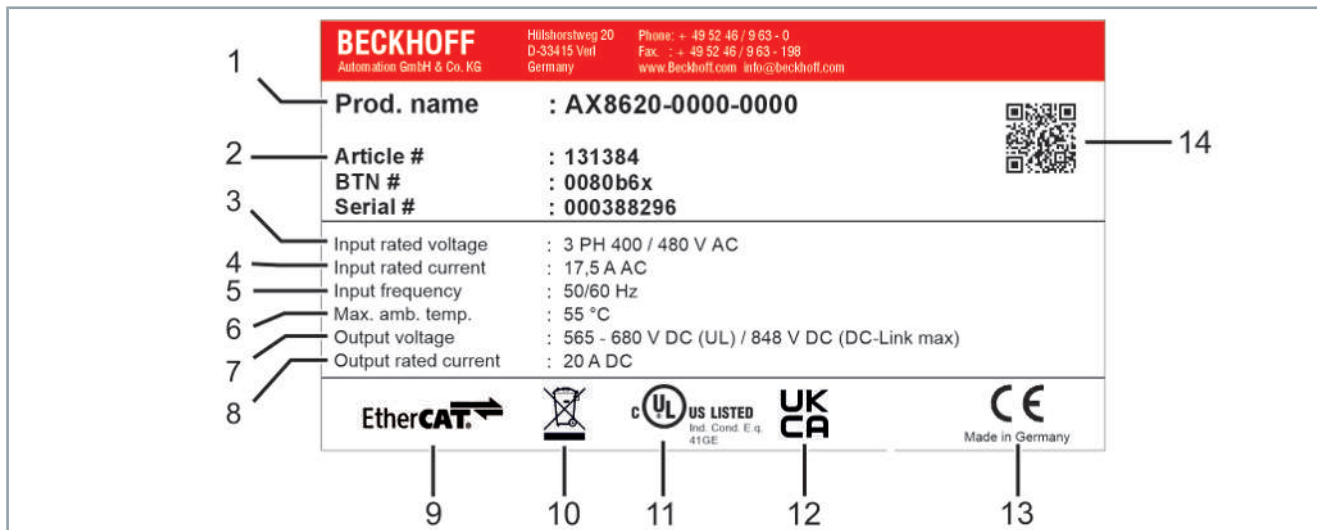

Item number	Explanation
1	Order number
2	Order number Beckhoff Traceability Number Serial number
3	Input rated voltage
4	Input rated current
5	Input frequency
6	Maximum ambient temperature
7	Output rated voltage
8	Output rated current
9	EtherCAT conformity
10	Disposal according to WEEE directive
11	cULus approval
12	UKCA conformity
13	CE approval
14	Data Matrix Code

3.1.3 Type key AX86xx

AX 8x yz - a b c d - 0000	Explanation
AX	<i>Product area</i> • Servo drive
8	<i>Series</i> • AX8000
x	<i>Supply</i> • 6 In combination with "a"
yz	<i>Nominal output current</i> • 00 = maximum 50 A _{DC} - DC power supply • 20 = 7 A _{DC} - Single-phase supply 20 A _{DC} - Three-phase supply • 40 = 40 A _{DC} - Three-phase supply
a	<i>Supply</i> • 0 = single-phase 100 to 240 V _{AC} or three-phase 200 to 480 V _{AC}
b	<i>Version</i> • 0 = Standard
c	<i>Version</i> • 0 = Standard
d	<i>Version</i> • 0 = Standard

3.2 Axis modules AX81xx, AX82xx

Axis module AX8108, AX8118,
AX8206

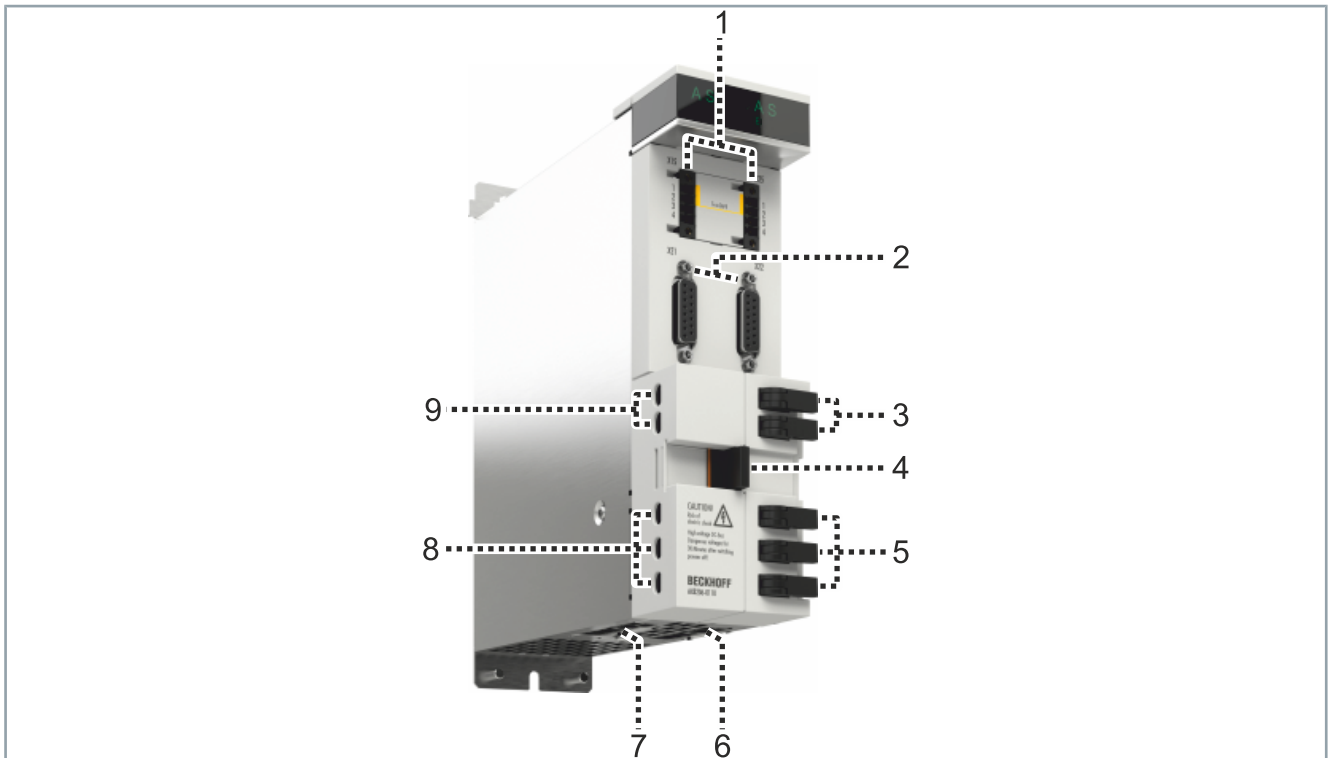

Item number	AX8108, AX8118	AX8206
1	X15: digital inputs channel A	X15: digital inputs channel A
	–	X25: digital inputs channel B
2	X11: Feedback connection, applies to feedback options AX81xx-0x10 and AX81xx-0x20	X11: Feedback connection channel A, applies to feedback option AX8206-0x10
	X12: Feedback connection, applies to feedback option AX81xx-0x10	X21: Feedback connection channel B, applies to feedback option AX8206-0x10
3	Quick coupling 24 V _{DC} ; AX-Bridge	
4	EtherCAT connection	
5	Quick coupling, DC link and protective earth PE; AX-Bridge	
6	X13: Motor connector channel A, 8-pin; U, V, W, PE, T+/OCT+, T-/OCT-, B+, B-	X23: Motor connector channel B, 8-pin; U, V, W, PE, T+/OCT+, T-/OCT-, B+, B-
7	–	X13: Motor connector channel A, 8-pin; U, V, W, PE, T+/OCT+, T-/OCT-, B+, B-
8	AX-Bridge: DC link, FE	
9	AX-Bridge: 24 V _{DC}	

Axis module AX8128

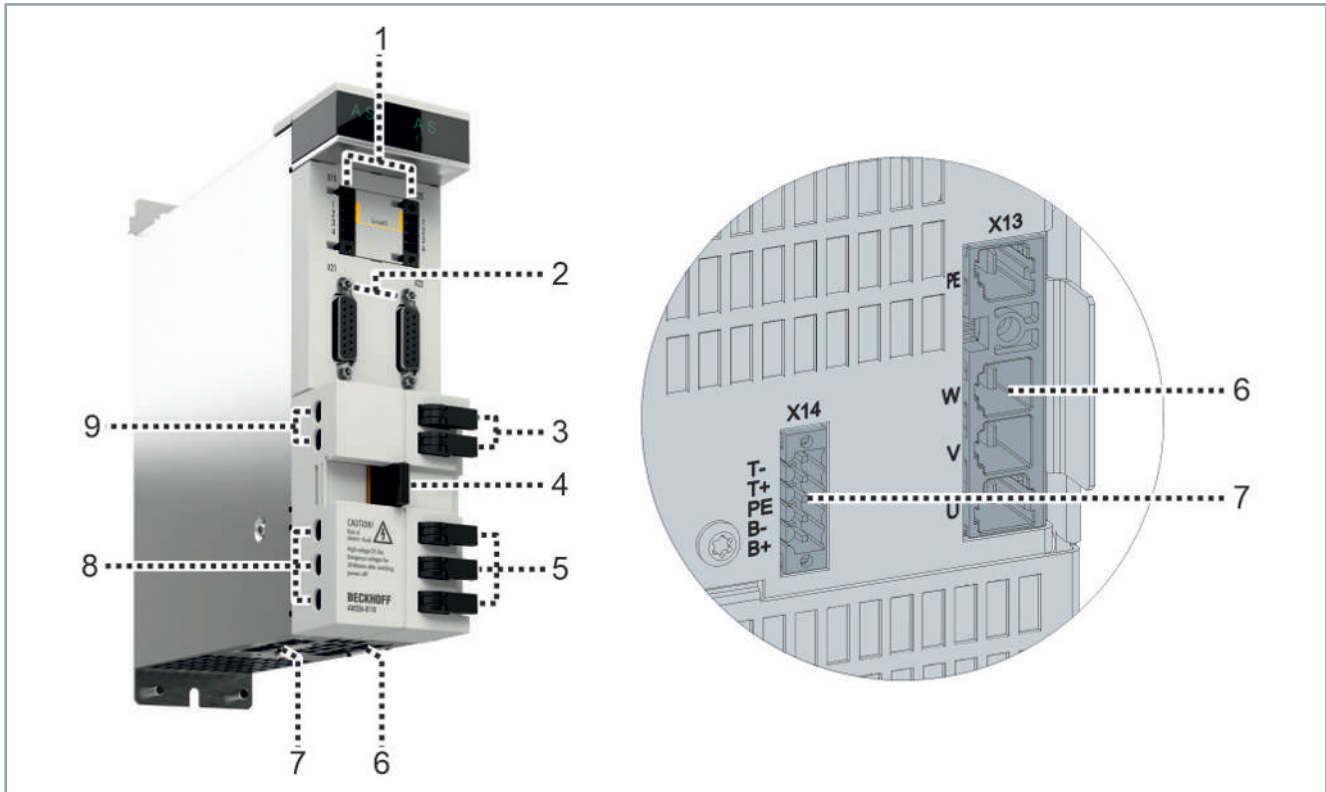

Item number	AX8128
1	X15: digital inputs channel A
2	X11: Feedback connection, applies to feedback options AX8128-0x10 and AX8128-0x20
	X12: Feedback connection, applies to feedback option AX8128-0x10
3	Quick coupling 24 V _{DC} ; AX-Bridge
4	EtherCAT connection
5	Quick coupling, DC link and protective earth PE; AX-Bridge
6	X13: Motor connector channel A, 8-pin; U, V, W, PE
7	X14: T+/OCT+, T-/OCT-, B+, B-
8	AX-Bridge: DC link, FE
9	AX-Bridge: 24 V _{DC}

3.2.1 Name plate AX81xx, AX82xx

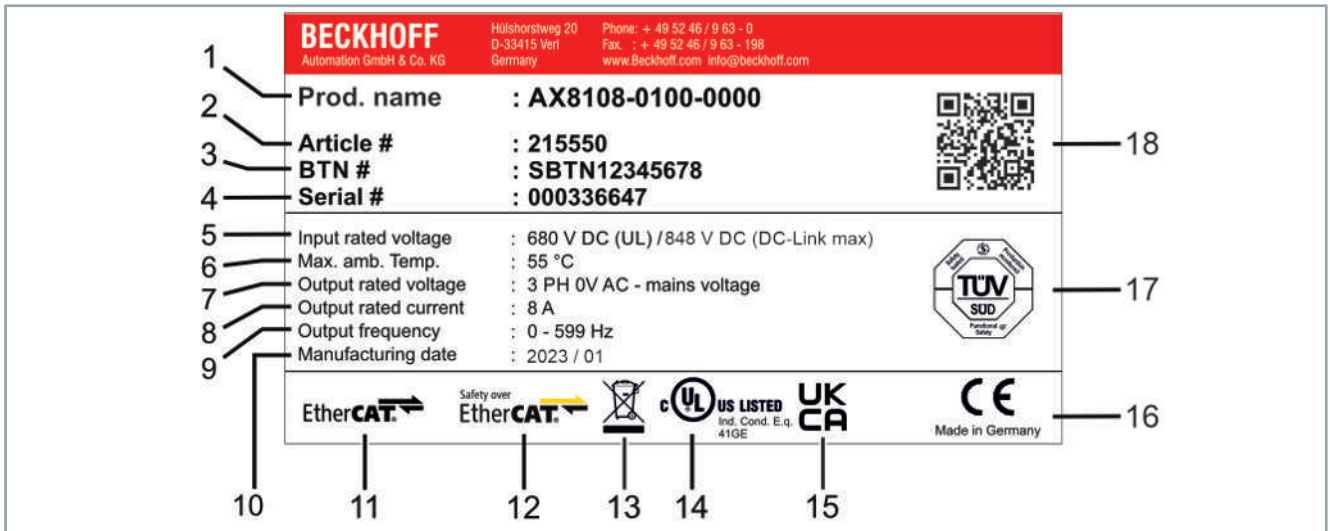

Item number	Explanation
1	Order number
2	Order number
3	Beckhoff traceability number
4	Serial number
5	Input rated voltage
6	Maximum ambient temperature
7	Output rated voltage
8	Output rated current
9	Output frequency range
10	Date of manufacture
11	EtherCAT conformity
12	Safety over EtherCAT conformity • Order designations AX8xxx-x1xx and AX8xxx-x2xx only
13	Disposal according to WEEE directive
14	cULus approval
15	UKCA conformity
16	CE conformity
17	TÜV certification • Order designations AX8xxx-x1xx and AX8xxx-x2xx only
18	Data-Matrix Code

3.2.2 Type key AX81xx, AX82xx

AX 8x yz - a b c d - e f g h	Explanation
AX	<i>Product area</i> • Servo drives
8	<i>Series</i> • AX8000
x	<i>Axis module</i> • 1 = 1-channel axis module • 2 = 2-channel axis module
yz	<i>Channel nominal current</i> • 06 = 2 x 6 A • 08 = 1 x 8 A • 18 = 1 x 18 A • 28 = 1 x 28 A
a	<i>DC link voltage</i> • 0 = 0 to 848 V _{DC}
b	<i>Safety function</i> • 0 = No safety function • 1 = Safety functions TwinSAFE, STO/SS1 • 2 = Safety functions TwinSAFE, Safe Motion (17 safety functions) All information on the safety functions integrated in the drive can be found in the chapter "Ordering options", [Page 35].
c	<i>Hardware features</i> • 0 = OCT/EnDat® 3 • 1 = EnDat® 2.2/22 or BiSS® C • 2 = EnDat® 2.2/22, BiSS® C, TTL (DIFF RS422), SinCos 1 Vpp; only available for 1-channel devices!
d	<i>Version</i> • 0 = standard
e	<i>Version</i> • 0 = standard
f	<i>Version</i> • 0 = standard
g	<i>Dual Use</i> • 0 = maximum rotary field frequency ≤ 599 Hz • 8 = rotary field frequency ≥ 600 Hz For further information, refer to the chapter "Dual Use", [Page 39].
h	<i>Version</i> • 0 = standard

3.3 Combined modules AX85xx

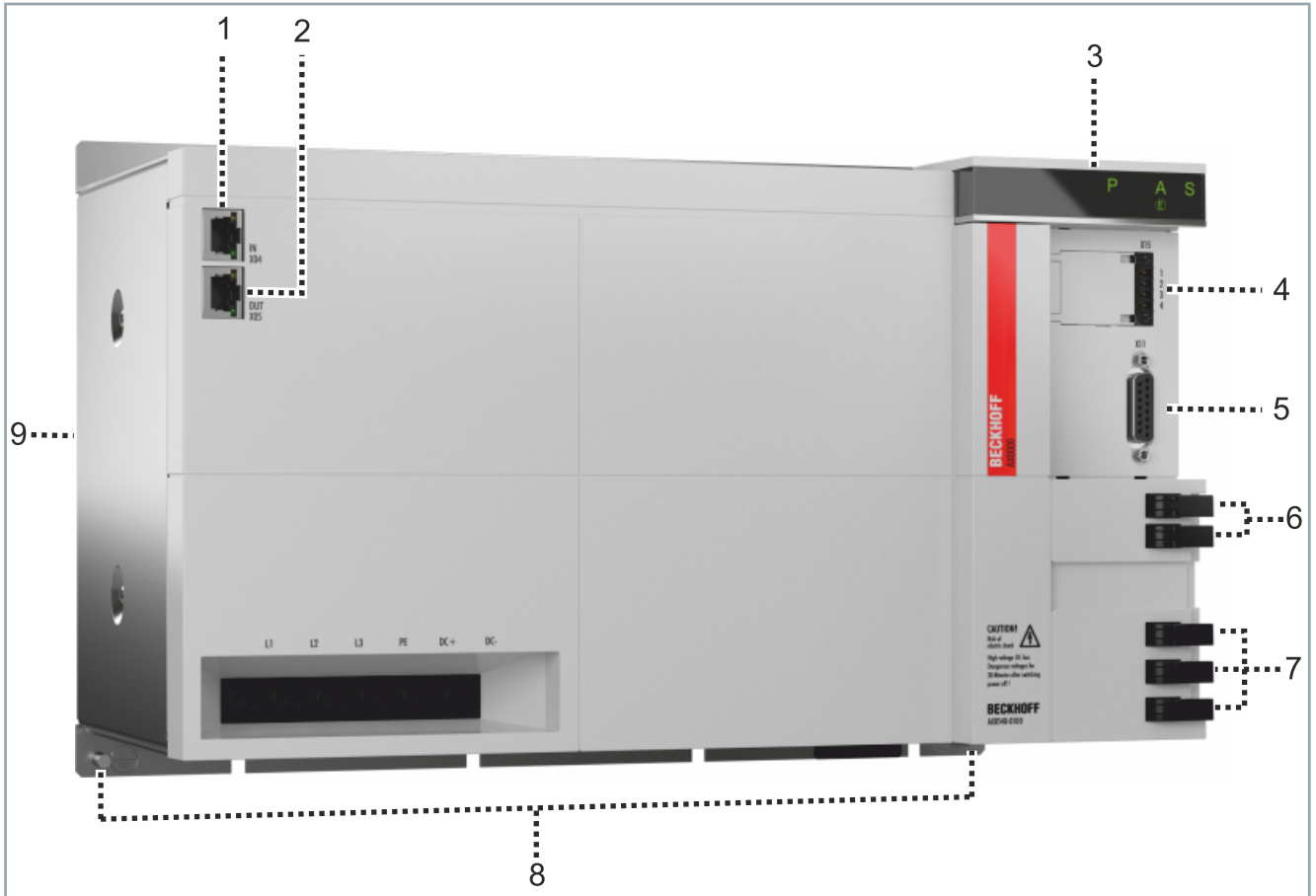

Item number	Explanation
1	Fieldbus EtherCAT input X04
2	Fieldbus EtherCAT output X05
3	Display
4	X15 digital inputs / TwinSAFE STO connection
5	Optional: X11 encoder feedback connection
6	Quick coupling 24 V _{DC} ; AX bridge
7	Quick coupling, DC link and protective earth PE; AX bridge
8	Grounding bolt
9	Housing

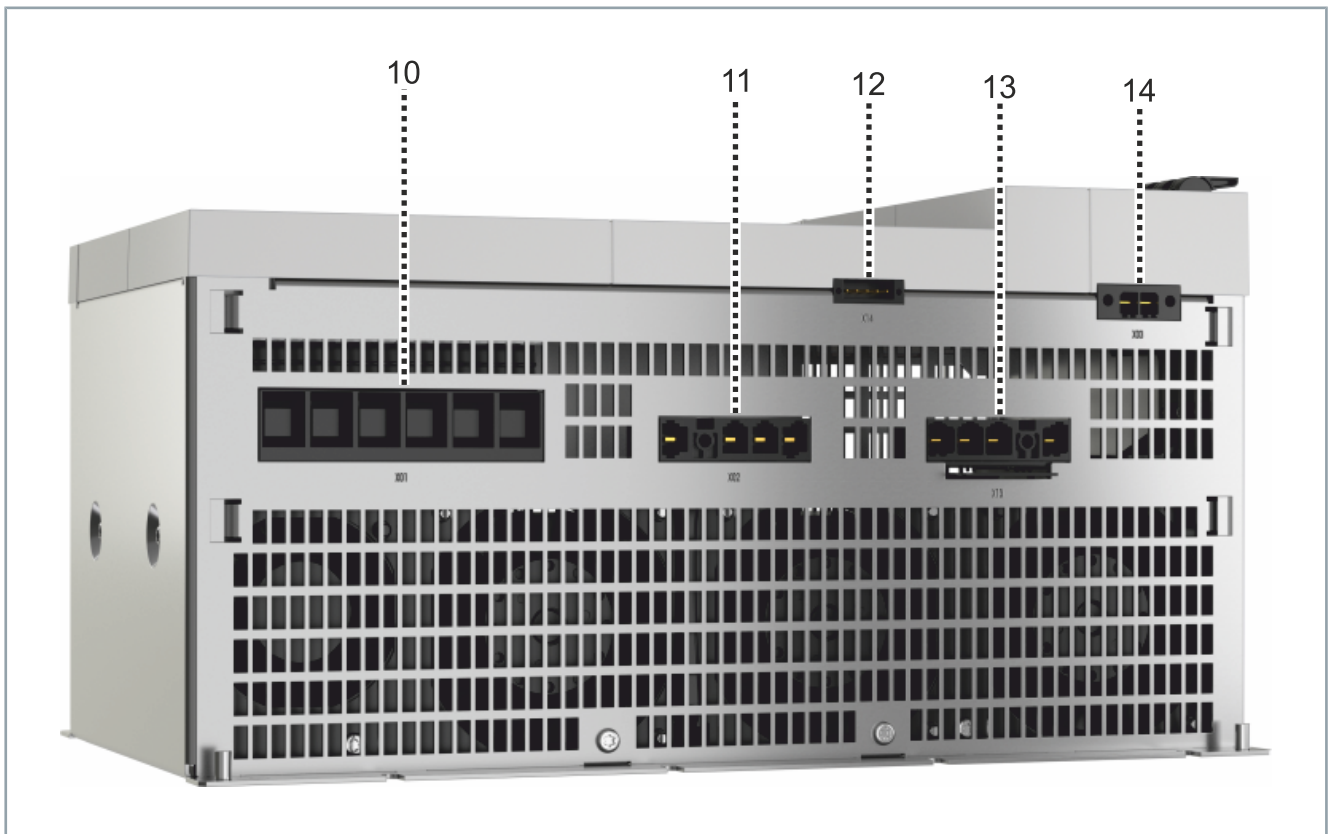

Item number	Explanation
10	X01 connection – mains supply and DC link
11	X02 connection – external braking resistor
12	X14 connection – holding brake, motor temperature / OCT
13	X13 plug – motor connection
14	X03 connection 24 V _{DC}

3.3.1 Name plate AX85xx

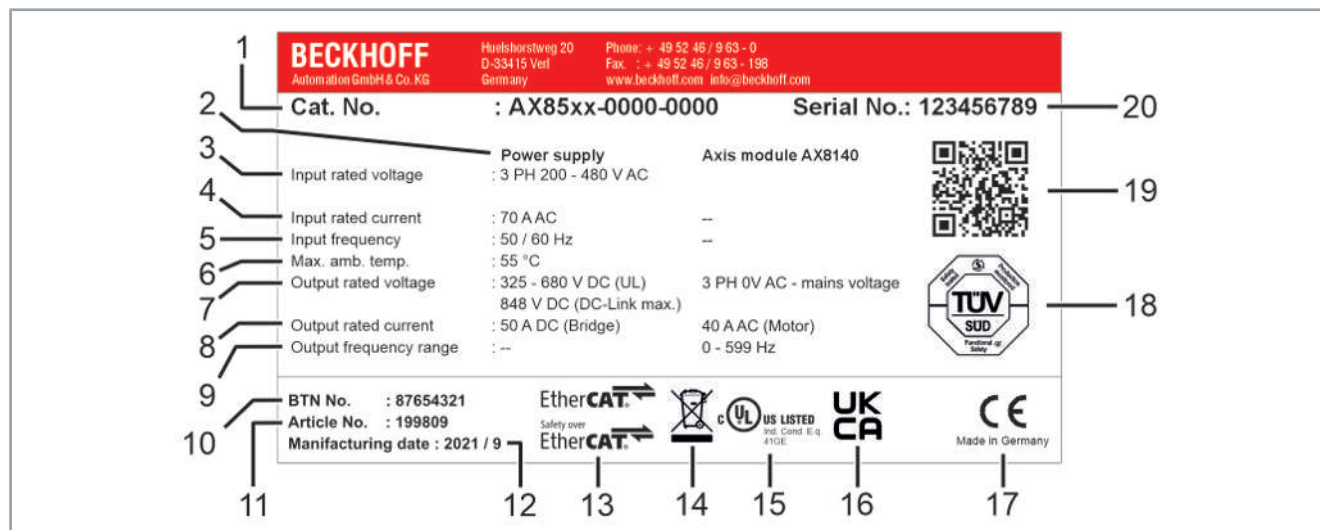

Item number	Explanation
1	Order number
2	Data for power supply module and axis module
3	Input rated voltage
4	Input rated current
5	Input frequency
6	Maximum ambient temperature
7	Output rated voltage
8	Output rated current
9	Output frequency range
10	Beckhoff traceability number
11	Order number
12	Date of manufacture
13	EtherCAT conformity Safety over EtherCAT conformity
14	Disposal according to WEEE directive
15	cULus approval
16	UKCA conformity
17	CE approval
18	TÜV certification
19	Data-Matrix Code
20	Serial number

3.3.2 Type key AX85xx

AX 85 yz - a b c d - e f g h	Explanation
AX	<i>Product area</i> • Servo drives
8	<i>Series</i> • AX8000
5	Combined power supply and axis module
yz	<i>Nominal DC link output current</i> • 25 = up to 50 A _{DC} • 40 = ≥ 35 A _{DC} , depending on the connected nominal motor current <i>Channel nominal current</i> • 25 = 1 x 25 A _{AC} • 40 = 1 x 40 A _{AC}
a	<i>Supply</i> • 0 = 200 to 480 V _{AC} <i>DC link voltage</i> • 0 = 0 to 848 V _{DC}
b	<i>Safety function</i> • 0 = No safety function • 1 = Safety functions TwinSAFE, STO/SS1 • 2 = Safety functions TwinSAFE, Safe Motion (17 safety functions) All information on the safety functions integrated in the drive can be found in the chapter "Ordering options", [Page 35].
c	<i>Hardware features</i> • 0 = OCT, EnDat® 3 • 1 = not available • 2 = EnDat® 2.2/22, BiSS® C, TTL (DIFF RS422), SinCos 1 Vpp
d	<i>Version</i> • 0 = standard
e	<i>Version</i> • 0 = standard
f	<i>Version</i> • 0 = standard
g	<i>Dual Use</i> • 0 = maximum rotary field frequency ≤ 599 Hz • 8 = rotary field frequency ≥ 600 Hz Further information can be found in the "Dual Use", [Page 39] chapter.
h	<i>Version</i> • 0 = standard

3.4 AX8810 capacitor module

3.4.1 Name plate AX8810

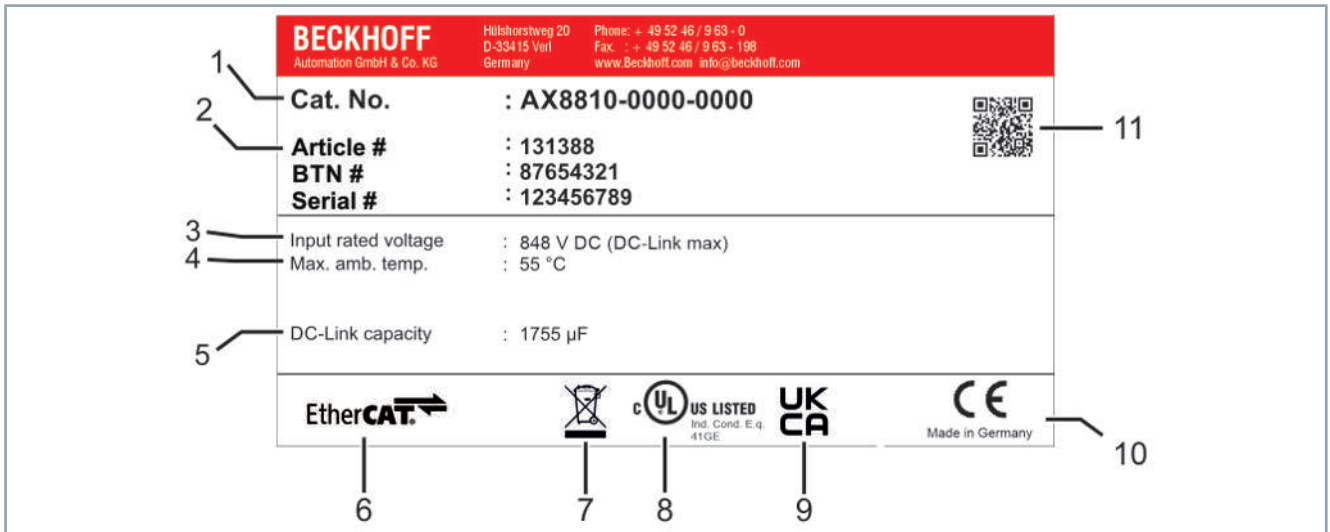

Item number	Explanation
1	Order number
2	Order number Beckhoff Traceability Number Serial number
3	Input rated voltage
4	Maximum ambient temperature
5	DC link capacitance
6	EtherCAT conformity
7	Disposal according to WEEE directive
8	cULus approval
9	UKCA conformity
10	CE conformity
11	Data-Matrix Code

3.4.2 Type key AX8810

AX 8 8 yz - a b c d - 0000	Explanation
AX	<i>Product area</i> • Servo drive
8	<i>Series</i> • AX8000
8	Option module
yz	<i>Option modules</i> • 10 = capacitor module
a	<i>Supply</i> • 0 = 0 to 848 V _{DC}
b	<i>Version</i> • 0 = Standard
c	<i>Version</i> • 0 = Standard
d	<i>Version</i> • 0 = Standard

3.5 Product characteristics

Short cycle times

With the servo drive you can implement fast and highly dynamic positioning tasks through the integrated control technology. EtherCAT enables the ideal connection to the PC-based control technology. With EtherCAT and the AX8000 multi-axis servo system and distributed clocks you can achieve minimum cycle times of 62.5 μ s, synchronicity and simultaneity in the drive technology.

Scalable nominal motor power

With the axis modules you can operate different nominal motor powers through scalable motor current measurement. A nominal motor current of between 1 A and 8 A can be set on an 8 A module without influencing the quality of the resolution.

Operation of different motor sizes

With a two-channel axis module you can connect two identical motor sizes or also different ones. The sum of the nominal currents of both servomotors is relevant for the selection of the axis module. The sum of the nominal currents of the axis modules is the most that can be provided at the same time here.

OCT – One Cable Technology

The AX8000 multi-axis servo system supports OCT, the one cable solution for power and feedback, in which the feedback signals are transmitted directly via the motor cable. All information required for control is transmitted interference-free and reliably via a digital interface.

The total cable length of an OCT connection is up to 100 m. One motor cable and a maximum of two extension cables can be used.

EnDat 3

In addition to OCT, the AX8000 multi-axis servo system also supports the transmission of EnDat® 3 signals directly via the Beckhoff motor cable.

The total cable length of an EnDat® 3 motor cable is up to 100 m. One motor cable and a maximum of two extension cables can be used.

Multi-feedback interface

The multi-feedback interface of the AX8000 multi-axis servo system supports the digital encoder systems EnDat 2.2/22 and BiSS C and the analog encoder systems TTL (DIFF RS422) and SinCos 1 Vpp:

- To increase the accuracy of axes with OCT, secondary feedback can be connected via the multi-feedback interface.
- When using AL8000 linear motors, the commutation encoder (primary feedback) is connected here.
- For third-party motors that do not support OCT, a different feedback system can be used here as the primary feedback.

Supported encoders and feedback systems

A wide range of different encoders and feedback systems are supported via the various encoder connections. These in turn are offered by many vendors. The firmware protocols are sometimes very extensive and, in the case of safety encoders, also very specific. However, the scope of implementation varies from vendor to vendor. Beckhoff Automation has implemented the respective interfaces to the best of its knowledge. However, compatibility with different vendor implementations cannot be guaranteed.

Some restrictions are listed below:

Hiperface DSL

- EKS / EKM36 is not supported
- EEK / EEM is supported as a standard encoder, but not as a safety encoder
- EDS / EDM35 is fully supported

EnDat 2.2 FS / EnDat® 3 FS

For the permitted EnDat® 2.2/22 FS and EnDat® 3 FS encoders, please refer to the operating instructions for the [AX8911 TwinSAFE option card](#).

High-speed capture inputs

The digital high-speed capture inputs record binary control signals from the process level and make them available for "latching" / "capturing" an encoder position. The signal propagation time of these inputs is 15 µs. There are two digital inputs per axis.

Diagnostics and parameter display

The display of the AX8000 multi-axis servo system shows error groups in various categories and is based on the 7-segment technology.

Toolless connection

The simple and fast connection of the DC link of power supply modules and several axis modules is enabled by the AX bridge. The connection takes place without tools with spring-loaded terminals for DC link, control circuit and EtherCAT. The compact design of the AX8000 multi-axis servo system enables simple mounting inside the control cabinet.

TwinSAFE safe drive technology

The AX8000 multi-axis servo system can be used to implement both basic functions (TwinSAFE STO/SS1) and complex safety functions (TwinSAFE Safe Motion) for safe drive technology. Depending on the product, the functionality can be realized via safe FSoE communication, with direct wiring or locally in the servo drive using the integrated TwinSAFE Logic.

3.6 Ordering options

Ordering options are defined via the type key and must be ordered separately. It is not possible to fit one at a later date.

3.6.1 TwinSAFE Drive-integrated safety technology

The TwinSAFE safety-related drive technology can be used to implement both basic functions (TwinSAFE STO/SS1) and sophisticated safety functions (TwinSAFE Safe Motion). Depending on the product, the functionality can be realized via safe FSoE communication, with direct wiring or locally in the servo drive using the integrated TwinSAFE Logic.

AX81xx-x1xx-xxxx
AX82xx-x1xx-xxxx
AX85xx-x1xx-xxxx

Axis module with TwinSAFE Logic and TwinSAFE STO/SS1

Technical data	
Function	Axis module with TwinSAFE Logic
Implementation STO	via local TwinSAFE Logic, via FSoE or fixed via safe inputs
Safe stop functions	Safe Torque Off (STO), Safe Stop 1 (SS1)
Safety standard	EN ISO 13849-1:2015 (Cat 4, PL e), EN 61508:2010 (SIL 3) and EN 62061:2005 + A1:2013/A2:2015 (SIL CL3)

AX81xx-x2xx-xxxx
AX82xx-x2xx-xxxx
AX85xx-x2xx-xxxx

Axis module with TwinSAFE Logic and TwinSAFE Safe Motion

Technical data	
Function	Axis module with TwinSAFE Logic
Implementation STO	via local TwinSAFE Logic, via FSoE or fixed via safe inputs
Safe stop functions	Safe Torque Off (STO), Safe Operating Stop (SOS), Safe Stop 1 (SS1), Safe Stop 2 (SS2)
Safe acceleration functions	Safe Maximum Acceleration (SMA), Safe Acceleration Range (SAR)
Safe brake functions	Safe Brake Control (SBC), Safe Brake Test (SBT)
Safe direction functions	Safe Direction positive (SDIp), Safe Direction negative (SDIn)
Safe speed functions	Safely Limited Speed (SLS), Safe Speed Range (SSR), Safe Speed Monitor (SSM), Safe Maximum Speed (SMS)
Safe position functions	Safely Limited Position (SLP), Safe CAM (SCA), Safely Limited Increment (SLI)
Safety standard	EN ISO 13849-1:2015 (Cat 4, PL e), EN 61508:2010 (SIL 3) and EN 62061:2005 + A1:2013/A2:2015 (SIL CL3)

Further information on this can be found in the chapter "TwinSAFE safe drive technology", [Page 78].

3.6.2 Multi-feedback interface

All axis modules of the AX8000 multi-axis servo system support OCT or EnDat 3. Linear servomotors AL8000 and third-party motors can also be operated with the digital encoder systems (EnDat 2.2/22, BiSS C) and analog encoder systems (TTL (DIFF RS422), SinCos 1 Vpp) via the optional multi-feedback interface. Only one feedback protocol can be selected per module.

Further information can be found in the "Multi-feedback interface", [Page 105] chapter.

AX81xx | Single-axis modules

Digital encoder systems

The following protocols are supported:

- EnDat® 2.2/22
- BiSS® C

The following modules of the AX8000 multi-axis servo system with multi-feedback interface support digital encoder systems:

Ordering information	Description
AX8108-0110-0000	Single-axis module, 8 A
AX8108-0210-0000	
AX8118-0110-0000	Single-axis module, 18 A
AX8118-0210-0000	

Digital and analog encoder systems

The following protocols are supported:

- EnDat® 2.2/22
- BiSS® C
- TTL (DIFF RS422)
- SinCos 1 Vpp

The following modules of the AX8000 multi-axis servo system with multi-feedback interface support digital and analog encoder systems:

Ordering information	Description
AX8108-0120-0000	Single-axis module, 8 A
AX8108-0220-0000	
AX8118-0120-0000	Single-axis module, 18 A
AX8118-0220-0000	
AX8128-0120-0000	Single-axis module, 28 A
AX8128-0220-0000	

AX82xx | Dual-axis modules

Digital encoder systems

The following protocols are supported:

- EnDat[®] 2.2/22
- BiSS[®] C

The following modules of the AX8000 multi-axis servo system with multi-feedback interface support digital encoder systems:

Ordering information	Description
AX8206-0110-0000	Dual-axis module, 2 x 6 A
AX8206-0210-0000	

AX85xx | Combined power supply and axis modules

Digital and analog encoder systems

The following protocols are supported:

- EnDat[®] 2.2/22
- BiSS[®] C
- TTL (DIFF RS422)
- SinCos 1 Vpp

The following modules of the AX8000 multi-axis servo system with multi-feedback interface support digital and analog encoder systems:

Ordering information	Description
AX8525-0120-0000	Combined power supply and axis module, 25 A
AX8525-0220-0000	
AX8540-0120-0000	Combined power supply and axis module, 40 A
AX8540-0220-0000	

3.7 Intended use

The modules of the AX8000 multi-axis servo system may be operated only for the intended activities defined in this documentation, taking into account the prescribed environmental conditions.

The components are to be installed only in closed control cabinets in electrical plants or machines and put into operation only as integrated components of the plant or machine.



Read the entire drive system documentation:

- This translation of the original instructions
- Complete machine documentation provided by the machine manufacturer

3.7.1 Improper use

Any type of use that exceeds the permissible values from the technical data is regarded as inappropriate and is thus prohibited.

The modules of the AX8000 multi-axis servo system are not suitable for use in the following areas:

- ATEX zones without suitable housing
- Areas with aggressive environments, for example aggressive gases or chemicals

The relevant standards and directives for EMC interference emissions must be complied with in residential areas.

3.8 Dual Use

According to the published EU Regulation No. 2021/821, commercially available frequency inverters are categorized as dual use items. This means that the Beckhoff AX8000 multi-axis servo system belongs to the category of goods that could be included in a dual use listing.

The goods list, "Annex 1" of the Dual Use directive 2021/821 has been amended accordingly:

- Frequency inverters (listed in goods list position 3A225) with a rotary field frequency of ≥ 600 Hz are subject to export control.
- Frequency inverters (listed in goods list position 3A225) with a rotary field frequency of ≤ 599 Hz are not subject to export control.

Dual use listing information

The type key of the AX8000 multi-axis servo system determines whether export control in accordance with a dual use listing is required. If the type key for the axis modules of the Beckhoff AX8000 multi-axis servo system contains a "g", export control in accordance with the dual use listing is required.

AX8xyz-abcd-efgh

Ordering information	Description
g =	dual use
0	product not subject to authorization as the rotating field frequency is limited to 599 Hz during production.
8	product subject to export authorization, if applicable

AX8xxx-xxxx-xx0x

In the standard design and according to the current state of production, the AX8000 multi-axis servo system is delivered with a maximum rotary field frequency of 599 Hz.

Ordering information	Description
AX8108-xxxx-xx0x	Single-axis module, 8 A, standard
AX8118-xxxx-xx0x	Single-axis module, 18 A, standard
AX8128-xxxx-xx0x	Single-axis module, 28 A, standard
AX8206-xxxx-xx0x	Dual-axis module, 2 x 6 A, standard
AX8525-xxxx-xx0x	Combined power supply and axis module, 25 A, standard
AX8540-xxxx-xx0x	Combined power supply and axis module, 40 A, standard

AX8xxx-xxxx-xx8x

Under certain conditions, the modules of the AX8000 multi-axis servo system are suitable for operating high-frequency spindles with a maximum speed of up to 96,000 rpm. In this version, the rotary field frequency is ≥ 600 Hz and the device is subject to export control.

Ordering information	Description
AX8108-xxxx-xx8x	Single-axis module, 8 A, dual use
AX8118-xxxx-xx8x	Single-axis module, 18 A, dual use
AX8128-xxxx-xx8x	Single-axis module, 28 A, dual use
AX8206-xxxx-xx8x	Dual-axis module, 2 x 6 A, dual use
AX8525-xxxx-xx8x	Combined power supply and axis module, 25 A, dual use
AX8540-xxxx-xx8x	Combined power supply and axis module, 40 A, dual use

4 Technical data

4.1 Data for operation and environment

NOTICE

Operate servo drives only under the specified environmental conditions

Operate the servo drives only in accordance with the specifications for operation and the environment listed in this chapter. This ensures a long service life and proper operation.

The lifetime of the servo drive may be shortened at temperatures above 40 °C and with encapsulated installation.

Beckhoff products are designed for operation under certain environmental conditions, which vary according to the product. The following specifications must be observed for operation and environment in order to achieve the optimum service life of the products.

Environmental requirements	
Climate category – operation	2K3 according to EN 60721
Ambient temperature during operation	-0 °C ... +40 °C Extended temperature range up to +55 °C with power derating of 2 % / K
Ambient temperature during transportation	-25 °C ... +70 °C, maximum fluctuation 20 K per hour
Ambient temperature during storage	-25 °C to +55 °C, maximum fluctuation 20 K per hour
Power derating	No power derating up to 1000 m above sea level From 1000 m up to a maximum of 3000 m above sea level with a power derating of 1 % / 100 m
Installation altitude	A reduction of the overvoltage category is necessary from an installation altitude of 2000 m up to maximally 3000 m above sea level. Observe derating.
Permissible humidity in operation	5 % to 95 % relative humidity, no condensation
Permissible humidity during transport and storage	5 % to 95 % relative humidity, no condensation
Corrosion protection	Not required: Special measures are to be taken in consultation with the vendor if the environmental conditions are extreme or if they differ from those described in this chapter.
Pollution degree	2 according to EN 60204 and EN 50178

Specifications for intended use	
Ventilation	Integrated and temperature-controlled fan
Insulation material class	F according to IEC 60085 and UL1446 class F
Protection rating	Devices IP20 Terminals IP00
Installation position	vertical
Vibration resistance	1 g, 150 Hz according to EN 61800-5-1
Shock resistance	5 g, 30 ms according to EN 60068-2-27
EMC requirements	conforms to EN 61800-3:2004 + A1:2012
Approvals	CE cULus UKCA See chapter: "Directives and standards", [Page 138]

4.2 Power supply module AX86xx

4.2.1 DC power supply module AX8600

Electrical data	DC
	AX8600-0000
Mains supply	
Rated input current [A_{DC}]	50
Rated supply voltage [V_{DC}]	560 / 640
SCCR value [kA]	65
System and peripheral voltage supply	
System voltage and peripheral voltage [V]	24 V DC +6/-10 %
Current consumption of the device [mA]	120
permissible sum current of all connected AX modules [A]	20
Rated output power	
At 600 V DC supply voltage [kW]	30
Basic power loss and power-dependent power loss	
Basic power loss [W]	8
Power-dependent power loss [W/kW]	6
<i>Example: With a rated output power of 5 kW, the total power loss is 8 W + (5 kW x 6 W/kW) = 38 W</i>	
DC link	
Maximum voltage [V_{DC}]	848
Capacitance [μ F]	405
Maximum peak output current [A_{DC}] for maximum 5 seconds	100
External braking resistor Dependent on the connected resistor	
Continuous braking power [kW]	1.6
Maximum braking power [kW]	21.8
Minimum braking resistor [Ω]	33
Mechanical data	DC
	AX8600-0000
Width [mm]	60
Height without connectors [mm]	230
Depth without connectors / accessories [mm]	192
Weight [kg]	2.5

Technical data

4.2.2 Power supply module AX8620 (20 A)

AX8620 - single-phase connection

Electrical data	Single-phase
	AX8620-0000
Mains supply	
Rated input current [A AC]	10
Maximum rated input current [A AC]	20
Rated supply voltage [V AC]	1 x 100 / 240
Mains filter	Integrated, category C3
SCCR value [kA]	65
System and peripheral voltage supply	
System voltage and peripheral voltage [V]	24 V DC +6/-10 %
Current consumption of the device [mA]	120
permissible sum current of all connected AX modules [A]	20
Rated output power	
240 V AC mains connection voltage [kW]	2
Basic power loss and power-dependent power loss	
Basic power loss [W]	8
Power-dependent power loss [W/kW]	6
<i>Example: With a rated output power of 5 kW, the total power loss is 8 W + (5 kW x 6 W/kW) = 38 W</i>	
DC link	
Maximum voltage [V _{DC}]	848
Capacitance [μF]	405
Rated output current without mains choke [A _{DC}]	5
Rated output current with mains choke [A _{DC}]	7
Peak output current [A _{DC}] for maximum 5 seconds	14
Internal braking resistor	
Continuous braking power [W]	75
Maximum braking power [kW]	21.8
External braking resistor	
Dependent on the connected resistor	
Continuous braking power [kW]	1.6
Maximum braking power [kW]	21.8
Minimum braking resistor [Ω]	33
Mechanical data	Single-phase
	AX8620
Width [mm]	60
Height without connectors [mm]	230
Depth without connectors / accessories [mm]	192
Weight [kg]	2.5

AX8620 - three-phase connection

Electrical data	Three-phase
	AX8620-0000
Mains supply	
Rated input current [I_{AC}]	17.5
Maximum rated input current [I_{AC}]	35
Rated supply voltage [V_{AC}]	3 x 200 / 480
Mains filter	Integrated, category C3
SCCR value [kA]	65
System and peripheral voltage supply	
24 V system voltage and peripheral voltage [V]	24 V DC +6/-10 %
24 V current consumption [mA]	120
permissible sum current of all connected AX modules [A]	20
Rated output power	
400 V_{AC} mains connection voltage [kW]	10.7
Basic power loss and power-dependent power loss	
Basic power loss [W]	8
Power-dependent power loss [W/kW]	6
<i>Example: With a rated output power of 5 kW, the total power loss is $8\text{ W} + (5\text{ kW} \times 6\text{ W/kW}) = 38\text{ W}$</i>	
DC link	
Maximum voltage [V_{DC}]	848
Capacitance [μF]	405
Rated output current without mains choke [I_{DC}]	20
Rated output current with mains choke [I_{DC}]	20
Peak output current [I_{DC}] for maximum 5 seconds	40
Internal braking resistor	
Continuous braking power [W]	75
Maximum braking power [kW]	21.8
External braking resistor	
Dependent on the connected resistor	
Continuous braking power [kW]	1.6
Maximum braking power [kW]	21.8
Minimum braking resistor [Ω]	33
Mechanical data	Three-phase
	AX8620-0000
Width [mm]	60
Height without connectors [mm]	230
Depth without connectors / accessories [mm]	192
Weight [kg]	2.5

Technical data

4.2.3 Power supply module AX8640 (40 A)

AX8640 - three-phase connection

Electrical data	Three-phase
	AX8640-0000
Mains supply	
Rated input current [A_{AC}]	35
Maximum rated input current [A_{AC}]	70
Rated supply voltage [V_{AC}]	3 x 200 / 480
Mains filter	Integrated, category C3
SCCR value [kA]	65
System and peripheral voltage supply	
24 V system voltage and peripheral voltage [V]	24 V DC +6/-10 %
24 V current consumption [mA]	120
permissible sum current of all connected AX modules [A]	20
Rated output power	
400 V_{AC} mains connection voltage [kW]	21.4
Basic power loss and power-dependent power loss	
Basic power loss [W]	8
Power-dependent power loss [W/kW]	6
<i>Example: With a rated output power of 5 kW, the total power loss is 8 W + (5 kW x 6 W/kW) = 38 W</i>	
DC link	
Maximum voltage [V_{DC}]	848
Capacitance [μF]	625
Rated output current without mains choke [A_{DC}]	40
Rated output current with mains choke [A_{DC}]	40
Peak output current [A_{DC}] for maximum 5 seconds	80
Internal braking resistor	
Continuous braking power [W]	125
Maximum braking power [kW]	43.6
External braking resistor	
Dependent on the connected resistor	
Continuous braking power [kW]	3.2
Maximum braking power [kW]	40.1
Minimum braking resistor [Ω]	18
Mechanical data	Three-phase
	AX8640-0000
Width [mm]	90
Height without connectors [mm]	230
Depth without connectors / accessories [mm]	192
Weight [kg]	3.5

4.3 Axis modules AX81x8, AX8206

4.3.1 1-channel axis modules AX8108, AX8118, AX8128

AX8108 (8 A)

Electrical data	Single-axis module 8 A
	AX8108-0000
Nominal output current [A]; 8/16 kHz	8 / 4
Minimum nominal output current with full current resolution [A]	1
24 V current consumption without holding brake [mA]	500
Maximum current brake output [A]	1
Basic power loss and power-dependent power loss	
Basic power loss [W]	12
Power-dependent power loss at 230 V _{AC} [W/A]	9
Power-dependent power loss at 400 V _{AC} [W/A]	11
Power-dependent power loss at 480 V _{AC} [W/A]	12.5
<i>Example for AX8108: With a nominal output current of 5 A at 400 V, the total power dissipation is 12 W + (5 A x 11 W/A) = 67 W</i>	
DC link	
Voltage range [V _{DC}]	0 to 848
Capacitance [μF]	135
Output current at 400 V_{AC} mains connection voltage	
Nominal output current [A]; 8/16 kHz	8 / 4
Peak output current [A] I _{rms} for maximum 5 seconds; 8 / 16 kHz	20 / 10
Output current at 480 V_{AC} mains connection voltage	
Nominal output current [A]; 8/16 kHz	8 / 4
Peak output current [A] I _{rms} for maximum 5 seconds; 8 / 16 kHz	18 / 9
Output frequency	
Output frequency of the limited standard version [Hz]	0...599
Output frequency of the dual-use version [Hz]	0...1600
Mechanical data	
Single-axis module 8 A	
AX8108-0000	
Width [mm]	60
Height without connectors [mm]	230
Depth without connectors / accessories [mm]	192
Weight [kg]	2

AX8118 (18 A)

Electrical data	Single-axis module 18 A
	AX8118-0000
Nominal output current [A]; 8/16 kHz	18 / 9
Minimum nominal output current with full current resolution [A]	5
24 V current consumption without holding brake [mA]	530
Maximum current brake output [A]	2
Basic power loss and power-dependent power loss	
Basic power loss [W]	12
Power-dependent power loss at 230 V _{AC} [W/A]	8
Power-dependent power loss at 400 V _{AC} [W/A]	10
Power-dependent power loss at 480 V _{AC} [W/A]	11
<i>Example for AX8108: With a nominal output current of 5 A at 400 V, the total power dissipation is 12 W + (5 A x 11 W/A) = 67 W</i>	
DC link	
Voltage range [V _{DC}]	0 to 848
Capacitance [μF]	405
Output current at 400 V_{AC} mains connection voltage	
Nominal output current [A]; 8/16 kHz	18 / 9
Peak output current [A] I _{rms} for maximum 5 seconds; 8 /16 kHz	40 / 20
Output current at 480 V_{AC} mains connection voltage	
Nominal output current [A]; 8/16 kHz	18 / 9
Peak output current [A] I _{rms} for maximum 5 seconds; 8 /16 kHz	36 / 18
Output frequency	
Output frequency of the limited standard version [Hz]	0...599
Output frequency of the dual-use version [Hz]	0...1600
Mechanical data	Single-axis module 18 A
	AX8118-0000
Width [mm]	90
Height without connectors [mm]	230
Depth without connectors / accessories [mm]	192
Weight [kg]	2.5

AX8128 (28 A)

Electrical data	Single-axis module 28 A
	AX8128-0000
Nominal output current [A]; 8/16 kHz	28 / 14
Minimum nominal output current with full current resolution [A]	7
24 V current consumption without holding brake [mA]	530
Maximum current brake output [A]	2
Basic power loss and power-dependent power loss	
Basic power loss [W]	12
Power-dependent power loss at 230 V _{AC} [W/A]	2
Power-dependent power loss at 400 V _{AC} [W/A]	3
Power-dependent power loss at 480 V _{AC} [W/A]	3.5
<i>Example for AX8108: With a nominal output current of 5 A at 400 V, the total power dissipation is 12 W + (5 A x 11 W/A) = 67 W</i>	
DC link	
Voltage range [V _{DC}]	0 to 848
Capacitance [μF]	660
Output current at 400 V_{AC} mains connection voltage	
Nominal output current [A]; 8/16 kHz	28 / 14
Peak output current [A] I _{rms} for maximum 5 seconds; 8 /16 kHz	50 / 40
Output current at 480 V_{AC} mains connection voltage	
Nominal output current [A]; 8/16 kHz	28 / 14
Peak output current [A] I _{rms} for maximum 5 seconds; 8 /16 kHz	50 / 36
Output frequency	
Output frequency of the limited standard version [Hz]	0...599
Output frequency of the dual-use version [Hz]	0...1600
Mechanical data	Single-axis module 28 A
	AX8128-0000
Width [mm]	90
Height without connectors [mm]	230
Depth without connectors / accessories [mm]	192
Weight [kg]	2.5

4.3.2 2-channel axis module AX8206

AX8206 (6 A)

Electrical data	Dual-axis module 6 A
	AX8206-0000
Nominal output current [A]	Per channel: 6
Minimum nominal output current with full current resolution [A]	1
24 V current consumption without holding brake [mA]	570
Maximum current brake output [A]	1
Basic power loss and power-dependent power loss	
Basic power loss [W]	12
Power-dependent power loss at 230 V _{AC} [W/A]	9
Power-dependent power loss at 400 V _{AC} [W/A]	11
Power-dependent power loss at 480 V _{AC} [W/A]	12.5
<i>Example for AX8108: With a nominal output current of 5 A at 400 V, the total power dissipation is 12 W + (5 A x 11 W/A) = 67 W</i>	
DC link	
Voltage range [V _{DC}]	0 to 848
Capacitance [μF]	135
Output current at 400 V_{AC} mains connection voltage	
Nominal output current [A]	Per channel: 6
Maximum nominal output current [A] for channel A; 8 / 16 kHz	8 / 4 <i>Up to FW 1.02: 6 / -</i>
Maximum nominal output current [A] for channel B; 8 / 16 kHz	8 / 4
Nominal output current as total device current [A]; 8 / 16 kHz	12 / 5.3
Peak output current [A] I _{rms} for maximum 5 seconds for channel A; 8 / 16 kHz	20 / 10 <i>Up to FW 1.02: 14 / -</i>
Peak output current [A] I _{rms} for maximum 5 seconds for channel B; 8 / 16 kHz	20 / 10
Peak output current I _{rms} for maximum 5 seconds as total device current [A]; 8 / 16 kHz	28 / 14
Output current at 480 V_{AC} mains connection voltage	
Nominal output current [A]	Per channel: 6
Maximum nominal output current [A] for channel A; 8/16 kHz	8 / 4 <i>Up to FW 1.02: 6 / -</i>
Maximum nominal output current [A] for channel B; 8/16 kHz	8 / 4
Nominal output current as total device current [A]; 8/16 kHz	12 / 5.3
Peak output current [A] I _{rms} for maximum 5 seconds for channel A; 8/16 kHz	18 / 9 <i>Up to FW 1.02: 14 / -</i>

Electrical data	Dual-axis module 6 A
	AX8206-0000
Peak output current [A] I_{rms} for maximum 5 seconds for channel B; 8/16 kHz	18 / 9
Peak output current I_{rms} for maximum 5 seconds as total device current [A]; 8/16 kHz	28 / 14
Output frequency	
limited output frequency of the standard version [Hz]	0...599
Output frequency of the dual-use version	0...1600
Mechanical data	Dual-axis module 6 A
	AX8206-0000
Width [mm]	60
Height without connectors [mm]	230
Depth without connectors / accessories [mm]	192
Weight [kg]	2

4.4 Combined power supply modules and axis modules AX8525, AX8540

Electrical data	Combined power supply modules and axis modules 25 A	Combined power supply modules and axis modules 40 A
	AX8525-0xx0	AX8540-0xx0
Mains supply		
Rated input current at 40 °C [I_{AC}]	70	
Maximum rated input current [I_{AC}]	140	
Rated supply voltage [V_{AC}]	3 x 200 / 480	
Mains filter	Integrated; category C3	
SCCR value [kA]	65	
System and peripheral voltage supply		
24 V system voltage and peripheral voltage [V]	24 V DC +6/-10 %	
24 V current consumption without holding brake [mA]	750	
Maximum current brake output [A]	2000	
permissible sum current of all connected AX modules [A]	20	
Rated output power		
At 400 V_{AC} mains connection voltage [kW]	42.8	
Basic power loss and power-dependent power loss [Basic power loss of the power supply module + power-dependent power loss of the power supply module + power-dependent power loss of the integrated axis module]		
Basic power loss [W]	18	
Power-dependent power loss at 230 V_{AC} [W/kW + W/A]	4 W/kW + 8 W/A	
Power-dependent power loss at 400 V_{AC} [W/kW + W/A]	4 W/kW + 10 W/A	
Power-dependent power loss at 480 V_{AC} [W/kW + W/A]	4 W/kW + 11 W/A	
Example: With a rated input power of 20 kW and a motor current from the directly connected motor of 8 A, the total power loss is $18 \text{ W} + (4 \text{ W/kW} \times 20 \text{ kW} + 10 \text{ W/A} \times 8 \text{ A}) = 178 \text{ W}$ The maximum power loss at 400 V_{AC} , rated power and highest rated motor current is $18 \text{ W} + (4 \text{ W/kW} \times 42.8 \text{ kW} + 10 \text{ W/A} \times 40 \text{ A}) = 590 \text{ W}$		
DC link		
Maximum voltage [V_{DC}]	848	
Capacitance [μF]	1520	
Rated output current [I_{DC}]	80; of which maximum 50 to the AX-Bridge	
Maximum rated output current [I_{DC}] for maximum 5 seconds	160; of which maximum 100 to the AX-Bridge	
Integrated axis module		
Output current at 400 V_{AC} mains connection voltage		
Rated output current [A]; 8 / 16 kHz	25 / 14	40 / 23.5
Peak output current I_{rms} [A] for maximum 5 seconds; 8 / 16 kHz	50 / 23	80 / 37.5
Output current at 480 V_{AC} mains connection voltage		
Rated output current [A]; 8 / 16 kHz	25 / 13	40 / 21
Peak output current I_{rms} [A] for maximum 5 seconds; 8 / 16 kHz	50 / 19	80 / 30.5
Output frequency		
Output frequency of the limited standard version [Hz]	0...599	
Output frequency of the dual-use version [Hz]	0...1600	

Electrical data	Combined power supply modules and axis modules 25 A	Combined power supply modules and axis modules 40 A
	AX8525-0xx0	AX8540-0xx0
Internal braking resistor		
Continuous braking power [W]	200	
Maximum braking power [kW]	68	
External braking resistor		
Minimum resistance value [Ω]	10	
Continuous braking power [kW]	6	
Maximum braking power [kW]	68	
Mechanical data	Combined power supply modules and axis modules 25 A	Combined power supply modules and axis modules 40 A
	AX8525-0xx0	AX8540-0xx0
Width [mm]	360	
Height [mm]	230	
Depth [mm]	192	
Weight [kg]	15	

4.5 AX8810 capacitor module

Electrical data	AX8810-0000
DC link	
Maximum voltage [V_{DC}]	848
Capacitance [μF]	1755
Mechanical data	AX8810-0000
Width [mm]	60
Height without connectors [mm]	230
Depth without connectors / accessories [mm]	192
Weight [kg]	1.9

4.6 Dimensional drawings

- Dimensions without connectors and cables
- All figures in millimeters

4.6.1 Narrow modules (AX8108, AX8206, AX8600, AX8620, AX8810)

AX8600, AX8620

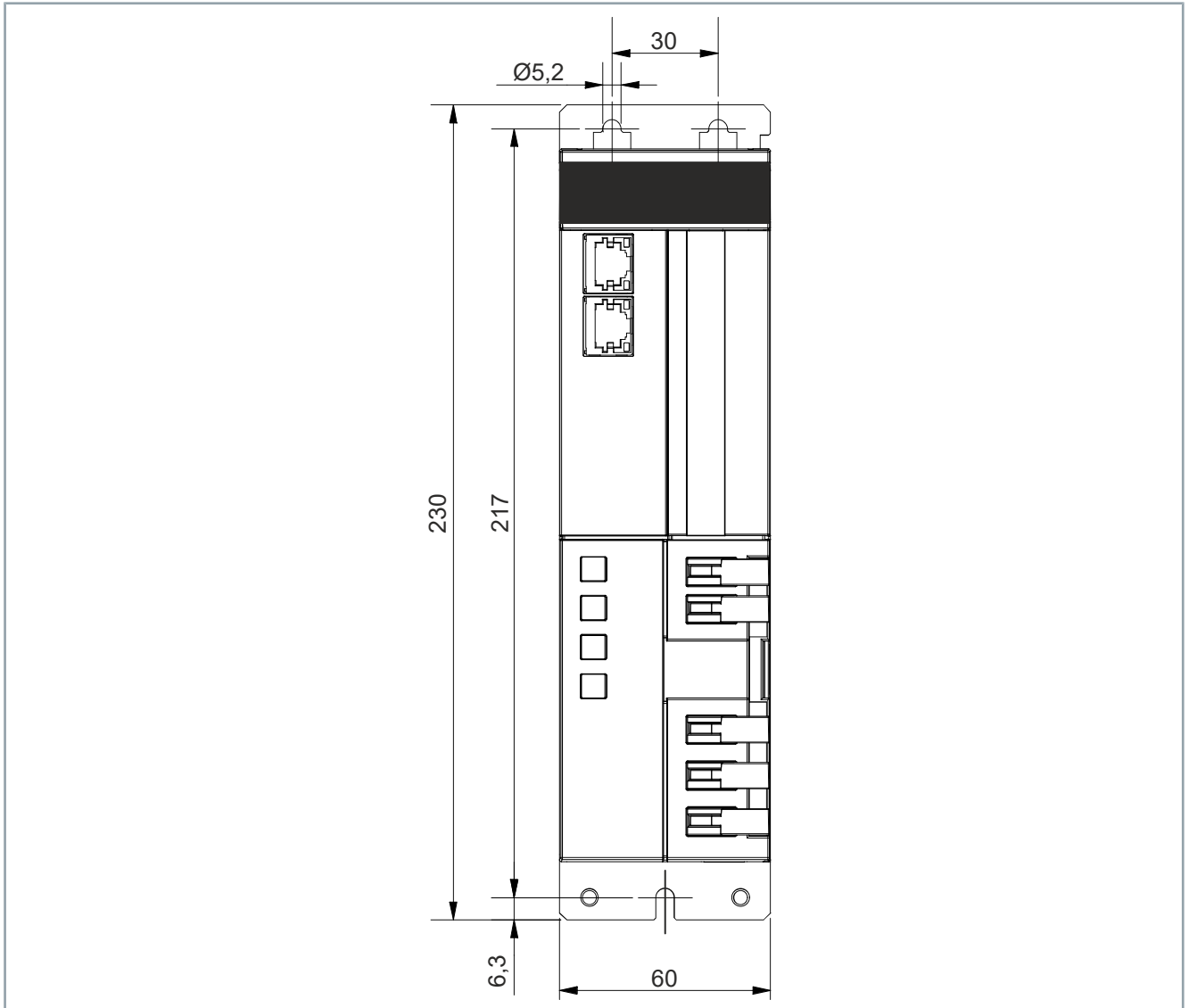

AX8108, AX8206, AX8810

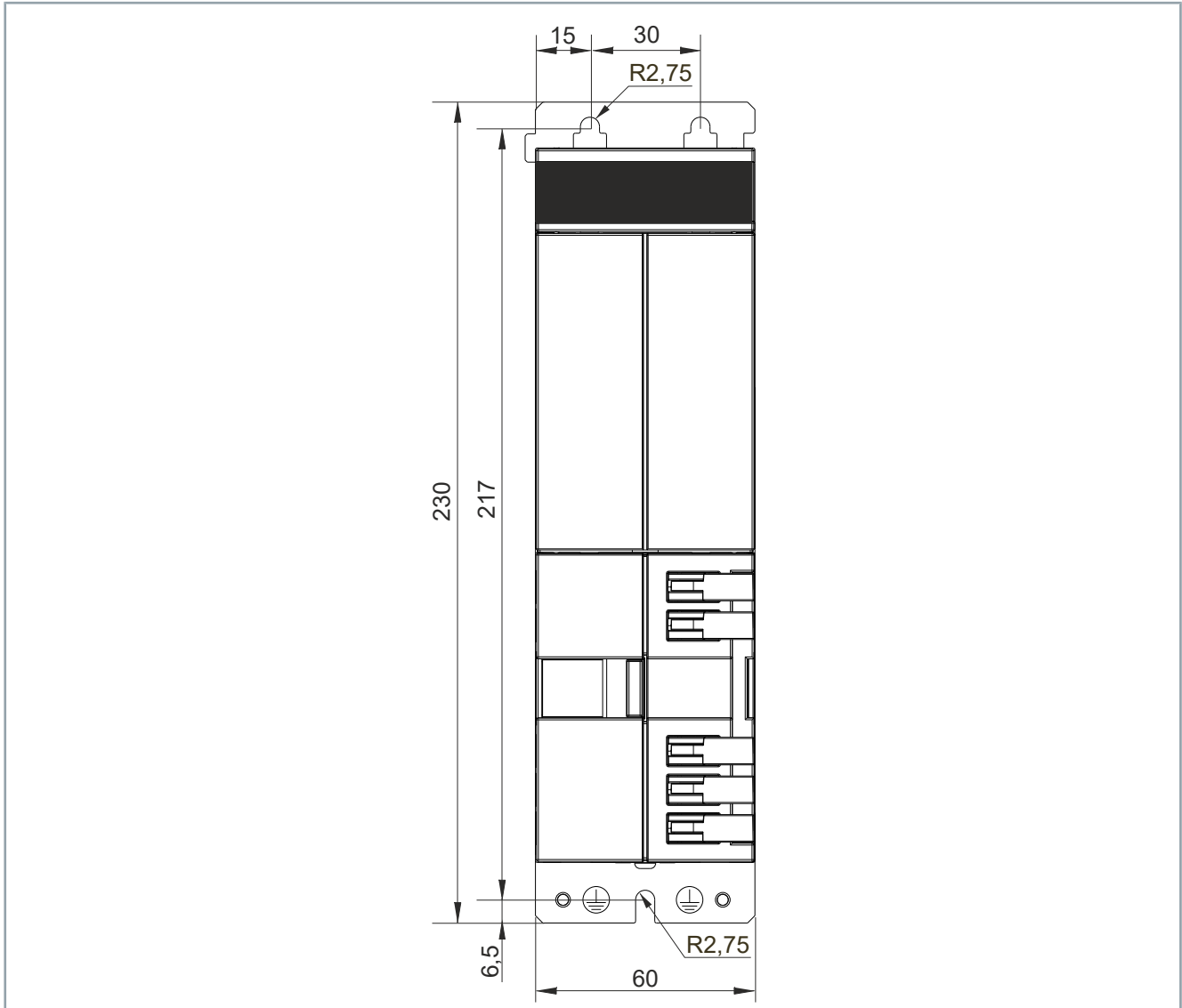

Illustration: Axis modules AX8108, AX8206 and capacitor module AX8810

4.6.2 Wide modules (AX8118, AX8128, AX8640)

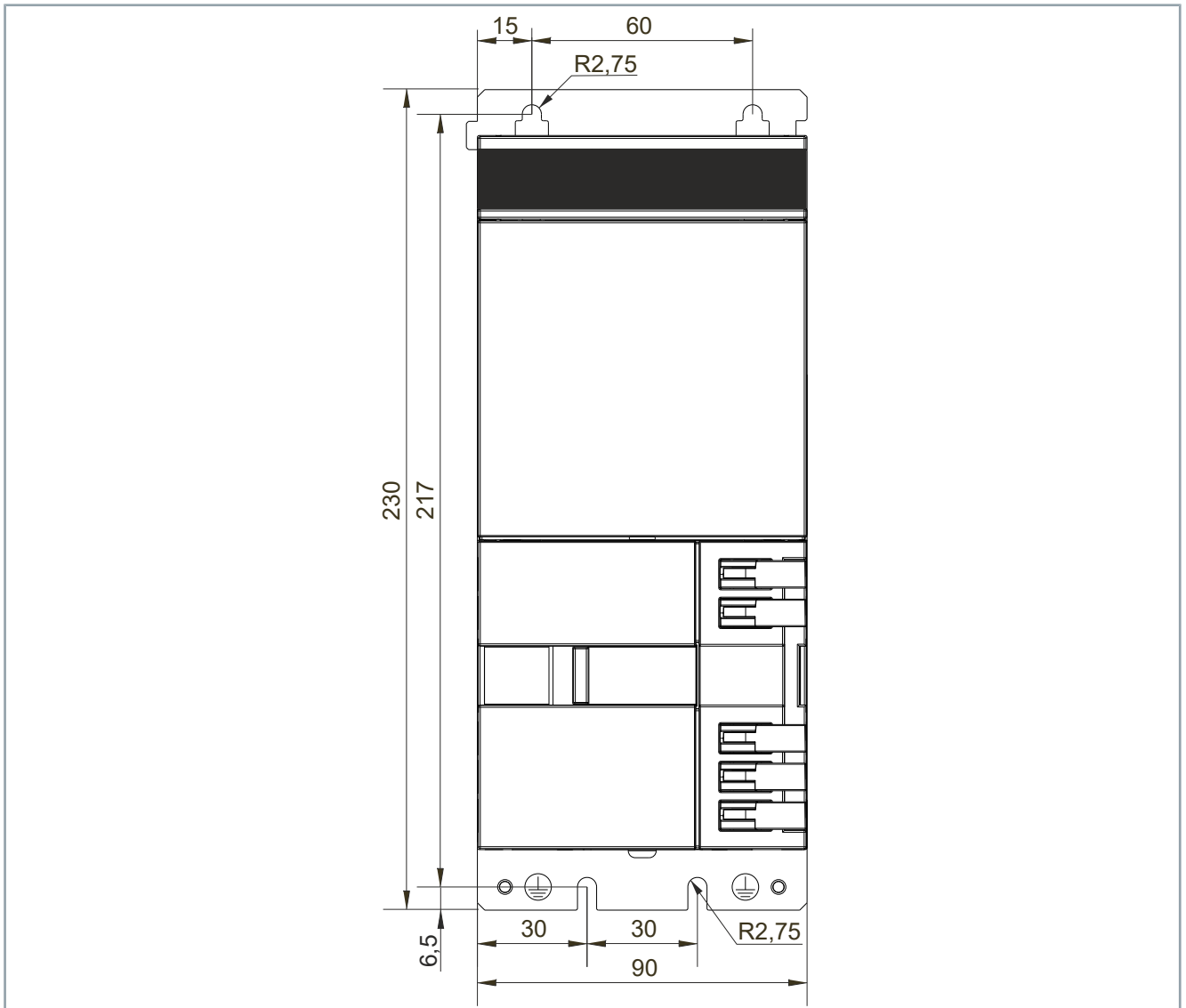

Illustration: Power supply modules AX8640 and Axis modules AX8118

4.6.3 Combined modules (AX8525, AX8540)

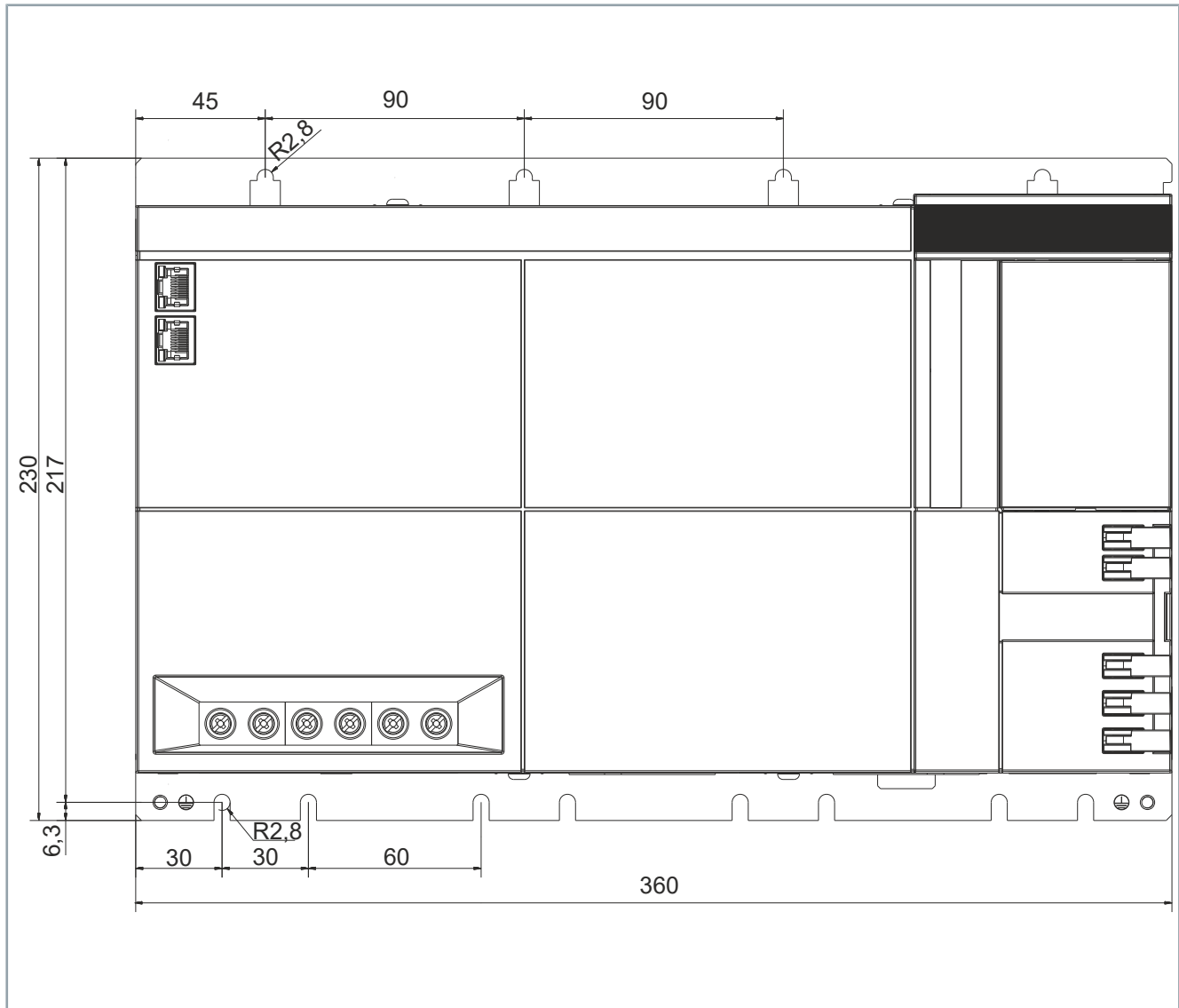

Illustration: Combined power supply modules and axis modules AX8525, AX8540

5 Scope of supply



Check the scope of supply for missing or damaged parts

Check your delivery for completeness. If any parts are missing or became damaged during transport, contact the carrier, vendor or our service department immediately.

Depending on the application, the scope of delivery may consist of different components and documents. Please check the delivery.

Power supply module AX8600

Name	Function
Quick reference guide	• Information
Hexagon nuts	• 2 pieces
ZS4800-2002 connector plug for slot X01	• DC link • 24 V DC supply • External braking resistor [+]

Power supply module AX8620

Name	Function
Operating Instructions	• Information
Hexagon nuts	• 2 pieces
ZS4800-2001 connector plug for slot X01	• Mains supply • DC link • 24 V DC supply • External braking resistor [+]

Power supply module AX8640

Name	Function
Operating Instructions	• Information
Hexagon nuts	• 2 pieces
ZS4800-2041 connector plug for slot X01	• Mains supply
ZS4800-2042 connector plug for slot X02	• DC link • 24 V DC supply • External braking resistor [+]

AX8108, AX8118, AX8128 axis modules

Name	Function
Short information	• Information
Grounding hanger	• Grounding
Hexagon nuts	• 2 pieces
ZS4800-2015 connector plug for slot X15	• Digital inputs and outputs

Axis module AX8206

Name	Function
Short information	• Information
Grounding hanger	• Grounding
Hexagon nuts	• 2 pieces
ZS4800-2015 connector plug for slot X15	• Digital inputs and outputs, channel 1
ZS4800-2015 connector plug for slot X25	• Digital inputs and outputs, channel 2

Scope of supply

Combined AX85xx power supply modules and axis modules





Name	Function
Operating Instructions	• Information
Hexagon nuts	• 2 pieces
ZS4500-2047 connector plug for slot X02	• External braking resistor [+]
ZS4800-2003 connector plug for slot X03	• 24 V DC supply
ZS4800-2015 connector plug for slot X15	• Digital inputs and outputs

AX8810 capacitor module

Name	Function
Short information	• Information
Grounding hanger	• Grounding
Hexagon nuts	• 2 pieces

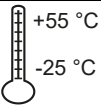
5.1 Packaging

Instructions for handling are printed on the packaging:

Symbol	Explanation
	That is the highest and lowest temperature at which you may store.
	This is the correct position for the packaging.
	The packaging must be protected from moisture.
	The contents are fragile.

The table below shows the dimensions of the packages:

Module type	Altitude	Width	Depth
AX8108, AX8206, AX8600, AX8620, AX8810	370	275	130
AX8118, AX8128, AX8640	395	275	170
AX8525, AX8540	490	385	290

All dimensions in mm.

6 Transport and storage

⚠ WARNING

Protect the servo drive against damage

Protect the servo drive against damage during transport and storage and adhere to the conditions.

Damage may result in hazardous voltages being present on the housing or exposed components and can lead to serious or even fatal injuries.

NOTICE

Avoid damage to the servo drive and loss of the guarantee

Observe the conditions and the following chapters on transport and storage.

Disregarding the conditions can lead to damage to the servo drive and invalidation of the guarantee.

NOTICE

Avoid short-circuit due to moisture

Condensed water can form during transport in cold weather or in case of extreme temperature differences. Make sure that no moisture collects in the servo drive. Equalize room temperatures slowly. Switch the servo drive on only when it is dry.

If the servo drive is not fully dry, condensed water can lead to a short circuit and damage to the servo drive when switching on.

6.1 Conditions

Care must be taken that the servo drive and individual components are not damaged during transport and storage. Observe the specifications in the following chapters and comply with the following conditions:

- Avoid electrostatic charging
- Avoid contact with highly insulating materials
- Temperature: -25 °C to +55 °C, maximum fluctuation 20 K/hour
- Air humidity: Max. relative humidity 95 %, non-condensing
- Use of suitable means of transport
- Use of the vendor's original packaging

The table shows the maximum stacking height in which you may store and transport the servo drives in their original packaging on a pallet:

AX8000 multi-axis servo system	Stacking height [pieces]
Power supply modules, axis modules, capacitor modules	8
Combined modules	3

6.2 Transport

NOTICE

Avoid high mechanical stresses

Use suitable means of transport and secure servo drives against high mechanical stress.

High mechanical stresses damage the servo drive and individual components.

All modules can be transported without aids.

6.3 Long-term storage

NOTICE

Limited functionality due to unformed capacitors

The dielectric in the DC link capacitors decreases over a very long storage period and the capacitors lose their forming. This can lead to considerable functional restrictions and even a shortened service life of the device.

- If the storage period exceeds 5 years, "reform the capacitors", [Page 81]

You have the option to store the servo drive over a short or longer period.

- ▶ Store the product in its original packaging.
- ▶ Adhere to the conditions specified in the chapter: "Transport and storage", [Page 61].
- ▶ Ensure the storage space is vibration-free.

7 Technical description

7.1 Installation position

The standard installation position of the servo drives in the control cabinet is the vertical installation position.

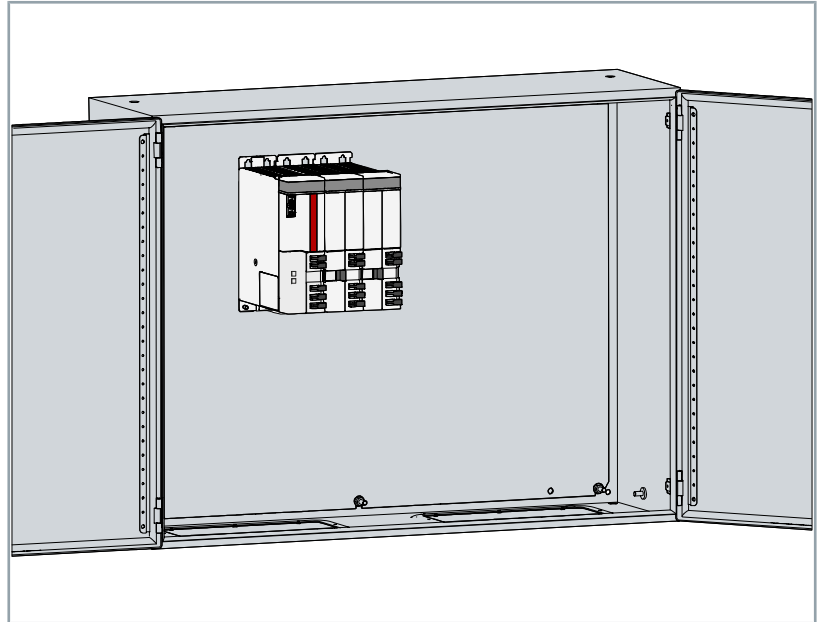

7.2 Residual current circuit breaker

Servo drives with a built-in mains filter may exhibit a small leakage current due to the capacitors in the filter. This fault current may cause malfunctions of standard residual current circuit breakers. Therefore, use so-called AC/DC-sensitive residual current circuit breakers type B, in which DC current is also accounted for. Beckhoff recommends residual current circuit breakers with switch-on delay.

7.3 Safe system stop

A power failure can lead to the uncontrolled run-out of the drive axes. Linear axes or lifting axes could then drive without braking against the end stop. Via the uninterruptible power supply in the Industrial PC, you have the possibility to buffer the supply voltage to the control electronics until all axes are safely stopped.

7.4 Wide voltage range of the power supply

Due to the wide voltage range of the power supply modules, the AX8000 multi-axis servo system can be operated worldwide on different voltage systems.

All networks with a grounded center point are permitted; TT / TN.

Data are given below for the wide voltage range of the power supply modules for the different supply networks:

Single-phase supply networks	Three-phase supply networks
1 x 100 _{-10%} V _{AC} to 1 x 240 _{+10%} V _{AC}	3 x 200 _{-10%} V _{AC} to 3 x 480 _{+8%} V _{AC}



Supply networks

Further information on all supply networks in the chapter:
→ Electrical installation, "supply networks", [Page 117]



Country-specific examples

The following table contains examples of different network systems in various countries:

Country	Single-phase supply networks	Three-phase supply networks
Japan	1 x 100 V _{AC}	3 x 200 V _{AC}
North America	1 x 115 V _{AC}	3 x 480 V _{AC}
Europe	1 x 230 V _{AC}	3 x 400 V _{AC}

7.5 Dimensioning

Important information on the DC link capacitance, the total motor cable lengths and the dimensioning of the 24 V_{DC} control voltage can be found below. Subsequently, there is a practical example.

7.5.1 DC link capacitance



Observe the maximum chargeable DC link capacitance

The maximum chargeable DC link capacitance must be considered when designing the machine or plant:

- The capacitances can be taken from the table below.

The power supply modules charge up the entire DC link when the mains supply is first switched on.

Maximum chargeable DC link capacitance

- All data in μF

Module	230 V _{AC}	400 V _{AC}	480 V _{AC}
AX8600-0000	25000	8500	6000
AX8620-0000	25000	8500	6000
AX8640-0000	40000	13500	9500
AX8525-0000	70000	23000	13000
AX8540-0000	70000	23000	13000

Special cases

AX8600 DC power supply module

If further axis and option modules are connected to an AX8600 DC power supply module that is coupled to the previous group in the DC link, the DC link capacitance of this new group does not have to be taken into account. The AX8600 module has its own charging circuit.

AX8831/AX8832 coupling module for AMP8000

AMP8805 distribution modules that are connected to an AX883x coupling module do not have to be taken into account in the chargeable DC link capacitance calculation, as the coupling modules have their own charging circuit.



Maximum chargeable DC link capacitance at 400 V_{AC}

The system includes:

- 1 x AX8640-0000 with 625 μF
- 10 x AX8206-0000 with 1350 μF
- 1 x AX8810-0000 with 1755 μF

That makes a total capacitance of 3730 μF.

The system is permissible, because a power supply module on the 400 V_{AC} supply network can charge up a capacitance of 13500 μF.



Charging time DC link capacitance

Charging time of the DC link when switched on the first time:

The charging time is calculated as follows:

- $\tau = R \times C$

After about 5 τ the charging time is completed.

Examples

AX8620 at 400 V_{AC} with maximum number of axis modules:

- $\tau = 33 \text{ ohm} \times 8500 \text{ } \mu\text{F} = 280 \text{ ms}$
Charging time = $5 \times 280 \text{ ms} = 1.4 \text{ s}$

AX8540 at 400 V_{AC} with maximum number of axis modules:

- $\tau = 10 \text{ ohm} \times 23000 \text{ } \mu\text{F} = 230 \text{ ms}$
Charging time = $5 \times 230 \text{ ms} = 1.15 \text{ s}$

7.5.2 Total motor cable length

In compliance with the EMC category C3, various total motor cable lengths apply for the AX8000 multi-axis servo system.

Without mains choke

Motor cable length	Total motor cable length	Number of axes per drive system
Maximum 25 m* per motor	Maximum 300 m per drive system	Limited by the maximum chargeable DC link capacitance and the 24 V _{DC} supply with a maximum of 20 A _{DC} The requirement is determined via the module current and motor braking current.

With mains choke

• Mains choke to be used: AX2090-ND80-xxxx

Motor cable length	Total motor cable length	Number of axes per drive system
Maximum 100 m* per motor	Maximum 500 m per drive system	Limited by the maximum chargeable DC link capacitance and the 24 V _{DC} supply with a maximum of 20 A _{DC} The requirement is determined via the module current and motor braking current.

*) Only applies for Beckhoff motors

When using cable lengths of individual axes greater than 15 m and a supply voltage greater than 400 V_{AC}, the motor cable length actually used (22 m here) must be entered in TwinCAT 3 Drive Manager 2:



Compliance with EMC category C2

The following requirements apply for compliance with EMC category C2:

Power supply module	Category C2	Max. total motor cable length
AX8620 1-phase	with mains filter AX2090-NF80-0010	up to 300 m
AX8620 3-phase	with mains filter AX2090-NF80-0020 and mains choke AX2090-ND80-0020	up to 500 m
AX8640	with mains filter AX2090-NF80-0040 and mains choke AX2090-ND80-0040	
AX8525 and AX8540	with mains filter AX2090-NF80-0080 and mains choke AX2090-ND80-0080	

Further information on mains filters can be found in the chapter Accessories under "Mains filters", [Page 135].

7.5.3 Control voltage



Dimensioning the 24 V_{DC} control voltage

The connected consumers must be summed in order to dimension the control voltage power supply unit:

- Power supply module
- Axis modules
- Capacitor module
- Motors with holding brake

Data for 24 V_{DC} power requirement

- "Technical data", [Page 41] or
- In the original operating instructions for the [AM8000 & AM8500 Synchronous Servomotors](#)

7.5.3.1 Practical example

The configured 480 V_{DC} drive system consists of:

Number	Component
4	Servomotors from the AM8031-0D21 series with a cable length of 4 m, 10 m, 15 m and 22 m
4	Servomotors from the AM8051-0G21 series with a cable length of 16 m, 18 m, 21 m and 25 m
4	Dual-axis modules from the AX8206 series
1	Power supply modules from the AX8620 series

Total standstill current I₀

The total standstill current I₀ relates to all servomotors listed in the practical example and corresponds to:

- 4 x 1.95 A for the AM8031 + 4 x 4.75 A for the AM8051 = 26.8 A

The total standstill current I₀ is now multiplied by the simultaneity factor. In the case of a machine tool this is relatively high, e.g. 0.9, because all axes can drive into the material at the same time. In the case of a handling system the factor is more likely to be 0.7. This then corresponds to:

- 26.8 A x 0.7 = 18.76 A

The AX8620 power supply module was selected on the basis of the calculations.

24 V_{DC} current consumption

The 24 V_{DC} current consumption relates to all the components listed in the practical example and corresponds to:

- 0.12 A for the AX8620 + 4 x 0.57 A for the AX8206 + 4 x 0.33 A for the holding brake with the AM8031 + 4 x 0.54 A for the holding brake with the AM8051 = 5.88 A_{DC}

Result

The maximum single cable length for the AM8051-0G21 is 25 m and is thus ≤ 25 m

The total cable length of all servomotors is 131 m and is thus ≤ 300 m

- No AX2090-ND80-xxxx mains choke required

The 24 V_{DC} current consumption of all components is 5.88 A_{DC} and is therefore ≤ 20 A_{DC}

- 24 V_{DC} power supply unit with at least 6 A nominal current provided

The maximum DC link capacitance is always related to the connection to a common AX8620 power supply module with 945 μ F and is thus ≤ 6000 μ F

7.6 Display

Information about the states of the individual modules is shown on the display of the AX8000 multi-axis servo system. There are different symbols for each module.

Display black:

The module is switched off.



7.6.1 Power supply module

Information about the meaning of the different symbols on the display of the power supply module is given below:

7.6.1.1 EtherCAT

E = EtherCAT

EtherCAT symbol lights up green:

The EtherCAT master is active.

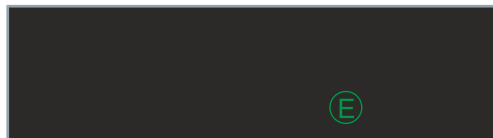

EtherCAT symbol flashes green:

The EtherCAT master is active, the configuration is inactive.

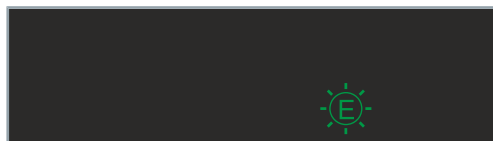

EtherCAT symbol flashes red:

EtherCAT error.



7.6.1.2 Mains voltage

P = Power supply



Power symbol lights up green:

The mains voltage is connected, and the DC link is charged.



Symbol flashes green:

The DC link is being charged / discharged.

Fast blinking: DC link voltage > 48 V

Slow flashing: DC link voltage ≤ 48 V



Power symbol lights up red:

Error.



Power symbol flashes red:

An error has occurred, but the DC link is being charged/discharged:

Fast blinking: DC link voltage > 48 V

Slow flashing: DC link voltage ≤ 48 V



EtherCAT and power symbol light up green:

The power supply module is ready to operate.

7.6.1.3 Debug firmware

D = Debug firmware



Debug firmware symbol flashes green:

a preliminary test version, debug firmware, is installed. Replace the version as soon as possible by a released firmware.

7.6.2 Axis module

In the case of a two-channel axis module, the display is vertically divided. The left column shows the symbols for channel A, the right column shows the symbols for channel B. The EtherCAT symbol is shown in the center.

Information on the meaning of the different symbols on the display of the single-channel axis module is given below:

7.6.2.1 EtherCAT

E = EtherCAT

Corresponds to the description for the power supply module:
See chapter "Power supply module display", [Page 70]

7.6.2.2 Axis module

A = axis module

Axis symbol lights up green:

The axis is enabled and free from errors.

Axis symbol flashes green:

Fast blinking: The axis is disabled and is being initialized.

Slow flashing: The axis is disabled and free from errors.

Axis symbol lights up red:

The module is in EtherCAT INIT state.

Axis symbol flashes red:

Error.

Axis symbol flashes green-red:

The error reaction of the axis is active.

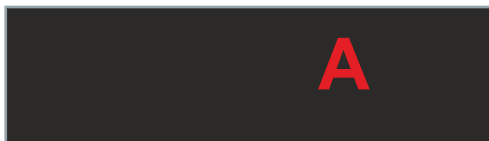

7.6.2.3 Safety

Information on the meaning of the different symbols on the display of the safety axis module is given below:

S = Safety



Safety symbol lights up green:

No safety error.

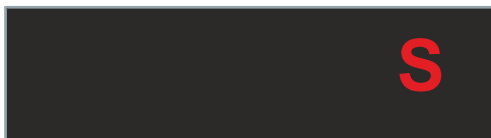

Safety symbol lights up red:

The axis is in state "STO".



Symbols of EtherCAT, axis module and safety light up green:

The safety axis module is in the normal operating state.

These symbols are only visible when the two-channel safety axis module has reached its operating state.

7.6.2.4 Debug firmware

D = Debug firmware



Debug firmware symbol flashes green:

a preliminary test version, debug firmware, is installed. Replace the version as soon as possible by a released firmware.

7.6.3 Combined module

The display of the combined module contains the information from the display of the "power supply module", [Page 70] and the "axis module", [Page 72]:

- EtherCAT
- Mains voltage
- Axis module
- Safety
- Debug firmware

7.7 AX8810 capacitor module

The AX8810 capacitor module expands the DC link capacity and is suitable for supporting the DC link. It is used to save energy: voltage peaks that occur when motors brake are recorded and stored. As a result, the AX8810 minimizes the use of the braking resistor as much as possible and reduces power loss. The capacitor module reduces the total connected load of the drive, and the fuse can be made smaller.

Use in combination with the single-phase supply to the AX8620 is particularly suitable for supporting the DC link.

7.7.1 Placement in the group



Example: system group with capacitor module

- Power supply module AX8620
- AX8810 capacitor module
- AX8118 axis module; 18 A
- AX8206 axis module; 2 x 6 A
- AX8108; 8 A

Beckhoff recommends that you place the optional capacitor module [2] directly adjacent to the power supply module [1]. Construct the AX8000 multi-axis servo system in decreasing order from the highest to the lowest rated output current.

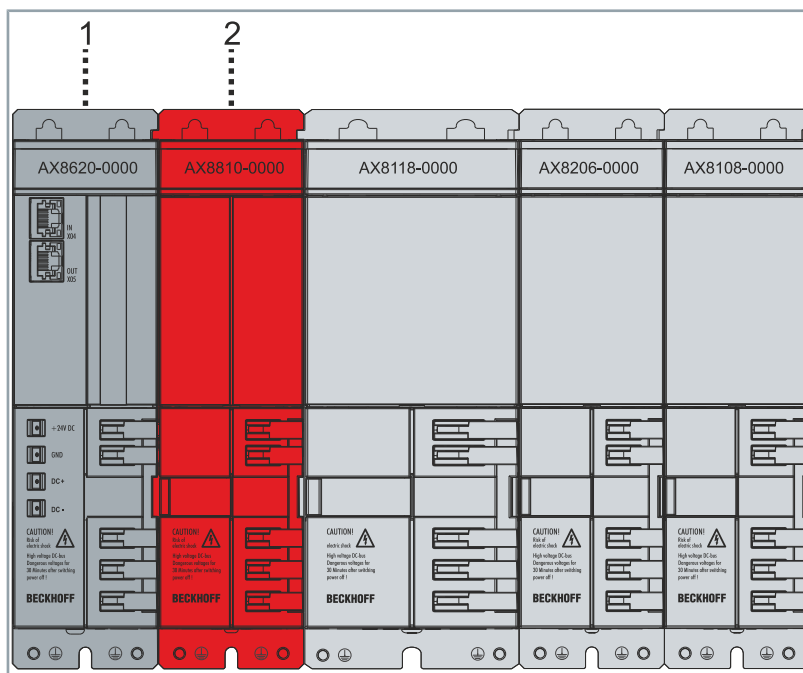

7.8 AX8600 Power supply module DC

⚠ DANGER

Warning of high voltage!

Even after switching off the mains voltage, a life-threatening DC link voltage can be present at the contacts of the AX8000 system for up to 30 minutes. Before removing the connector [1] of the ZK4875-900x DC link connection cable, the following steps must be observed:

- Check the DC voltage
- First disconnect the opposite side of the DC connection cable on the AX8600 DC power supply module

NOTICE

Possible loss of IEC and UL approval

The AX8600 DC power supply module and the DC link connection cable may only be used within the AX8000 system. Connecting third-party equipment to the line or feeding DC voltage from an external source is not covered by the IEC and UL approval of the components.

If, for example, an AX8000 multi-axis servo system is to be coupled with another system in the DC link in a multi-row configuration, you can implement this case using a ZK4875-900x-zzzz DC link connection cable and an AX8600 DC power supply module. The plug of the DC link connection cable [1] is connected to the AX-Bridge of the last AX8000 axis module [2] and the plug [3] in the next row is connected to the AX8600 [4].

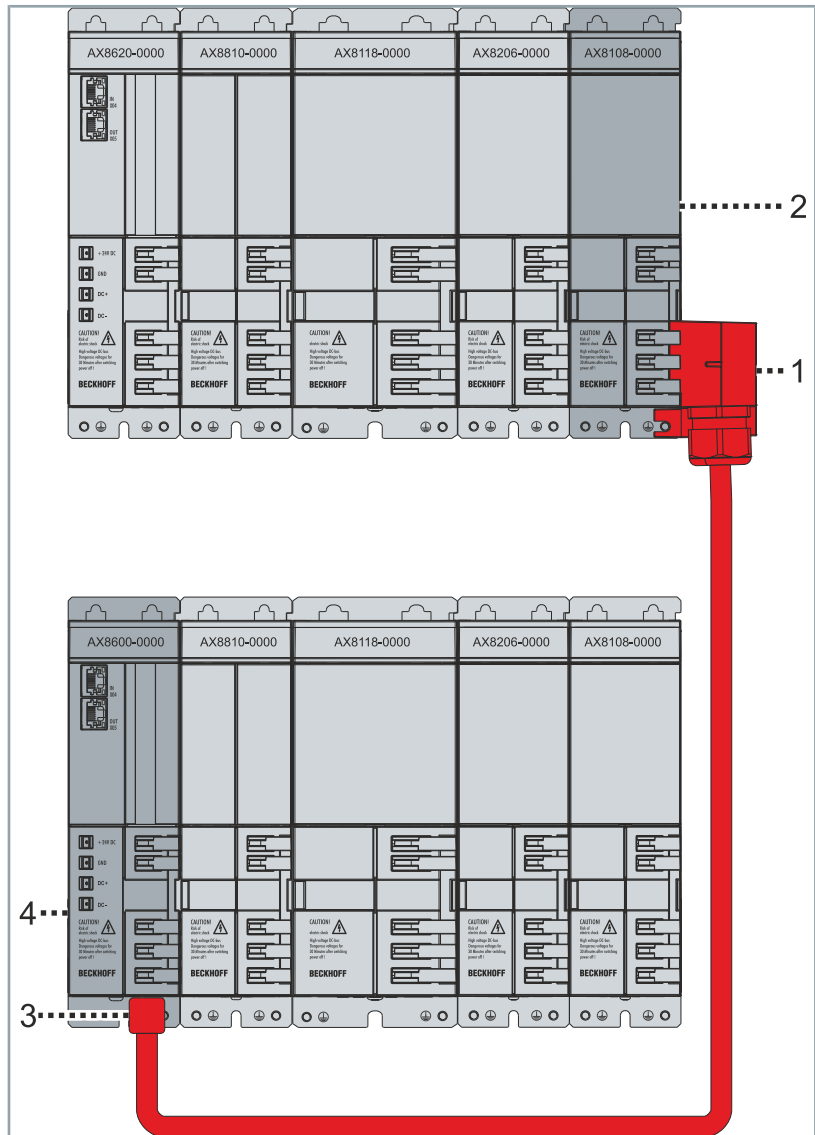

7.9 ZK4875-900x | DC link connection cable

Three different cables are available, depending on the power supply module used and the application:

- ZK4875-9004-xxxx | DC link connection cable between AX8620-powered AX-Bridge and AX8600
- ZK4875-9006-xxxx | DC link connection cable with integrated DC fuses between AX8xxx-powered AX-Bridge and the AX8820 universal regenerative unit
- ZK4875-9007-xxxx | DC link connection cable between AX8640/AX85xx-powered AX-Bridge and AX8600

The maximum cable length is 5 meters and the connection may only be made in the same control cabinet.

7.10 Third-party motors

The AX8000 axis modules also support the connection of third-party motors. This includes, for example, asynchronous motors, synchronous motors, linear motors and torque motors.

- Asynchronous motors can be operated in U/f mode without feedback.
- Synchronous motors can be operated without feedback in the "sensorless vector control" mode.
- For "closed loop vector control", an encoder with EnDat 2.2/22, BiSS C, Sin/Cos or TTL (RS422 diff.) can be connected via the multi-feedback interface.



The insulation system of the motor must comply with the stress category IVIC C (Impulse Voltage Insulation Class C).

7.11 TwinSAFE safe drive technology

AX8911 – TwinSAFE card for servo drives of the AX8xxx series

The AX8911 TwinSAFE drive option card is an optional extension of the Beckhoff AX8xxx servo drive series, in which it is permanently installed. The card enables you to define the safety functions by application. The type key of the servo drive determines whether it is a servo drive with STO (AX8xxx-x1xx) or Safe Motion (AX8xxx-x2xx). In the delivery state, a factory setting project with the safety function STO according to EN 61800-5-2 is integrated as an example. Further information can be found in the original operating instructions for the cards.

WARNING

Failure to observe the documentation for the TwinSAFE drive option cards may compromise safety

Only operate the TwinSAFE drive option card for the intended activities defined in the corresponding documentation, taking into account the specified values.

- Refer primarily to the documentation for the TwinSAFE drive option card.

Axis modules with TwinSAFE Safe Motion

The axis modules are optionally available with integrated safety functions. These conform to IEC 61800-5-2 and fulfill the following safety standards:

- DIN EN ISO 13849-1:2015, up to Cat 4, PL e
- EN 61508:2010, up to SIL 3
- EN 62061:2005 + A1:2013/A2:2015 up to SILCL3

Communication takes place via the FailSafe-over-EtherCAT protocol FSoE according to IEC 61784-3-12. When using the factory setting project, the safety function STO can be enabled either via two safe integrated digital inputs or FSoE.

Original operating instructions | AX8911 for AX8xxx-x1xx

 [Direct link to the original operating instructions of the TwinSAFE drive option card for servo drive AX8xxx-x1xx](#)

Original operating instructions | AX8911 for AX8xxx-x2xx

 [Direct link to the original operating instructions of the TwinSAFE drive option card for servo drive AX8xxx-x2xx](#)

Encoder connection for safe encoders (functional safety)

Original Beckhoff OCT motor cables or encoder cables are available for connecting Beckhoff servo or linear motors with a safe encoder (functional safety) for the implementation of TwinSAFE safety functions.

NOTICE Only OCT motor cables in which both the OCT wire pair and the brake wire pair are shielded separately may be used.



Third-party motors with safety encoders are not covered by the certification

The TÜV SÜD certificate applies to the list of approved components. Other components are not covered by the certificate. When using a third-party motor with a safety encoder, you are responsible for the correct installation of the safety encoder and the correctly assembled encoder connection cable. In addition, an FMEDA (Failure modes, effects and diagnostic analysis) and the necessary EMC and environmental tests must be carried out.

7.11.1 Beckhoff synchronous servomotors

Feedback system SIL 2-capable or higher

The encoder of the servomotor's feedback system must be at least SIL 2-capable in order to use TwinSAFE safe drive technology. In the type key of the Beckhoff servomotors, the feedback system is indicated by the letter "y". The servomotors with feedback options G...L are suitable for TwinSAFE in accordance with the ordering information.

AM8tuv-wxyz-a00

Ordering information	Description
y =	Feedback system
G	One Cable Technology for power and feedback; [...] Single-turn, absolute position within one revolution, 24-bit resolution, SIL 2-capable [...]
H	One Cable Technology for power and feedback; [...] Multi-turn, absolute position within 4096 revolutions, 24-bit resolution, SIL 2-capable [...]
I	EnDat® 3; One Cable Technology for power and feedback; [...] Single-turn, absolute position within one revolution, 19-bit resolution, SIL 3-capable [...]
J	EnDat® 3; One Cable Technology for power and feedback; [...] Multi-turn, absolute position within 4096 revolutions, 19-bit resolution 19, SIL 3-capable [...]
L	One Cable Technology for power and feedback; [...] Multi-turn, absolute position within 4096 revolutions, 24-bit resolution, SIL 2-capable [...]; Beckhoff Smart System Diagnosis (B/SSD)

¹⁾ To achieve SIL 3 or PLe, the notes in the [TwinSAFE Application Guide](#), chapter 7.2 *AdvPosMon with integrated EnDat® 3 encoder* must be observed.

7.11.2 Beckhoff linear servomotors

The axis modules of the AX8000 servo system also support safe drive technology with AL8000 linear servomotors. A suitable external encoder system must be selected. Please observe the following notes.

NOTICE

TwinSAFE STO/SS1

The basic TwinSAFE STO/SS1 functions can be used with linear motors. The connected feedback is not relevant here.

NOTICE

TwinSAFE Safe Motion

The sophisticated TwinSAFE Safe Motion safety functions require the connection of a functional safety encoder (Safe Motion Encoder):

- Hiperface DSL (Functional Safety)
- EnDat® 2.2/22 (Functional Safety)
- EnDat® 3 (Functional Safety)

NOTICE

Non-observance may endanger product safety

If an external encoder is used, the machine builder is responsible for

- the right choice of components
- correct installation in accordance with the encoder operating instructions
- assembling and testing the required encoder connection cable in accordance with the encoder operating instructions
- the FMEDA (Failure modes, effects and diagnostic analysis)

7.11.3 Third-party motors and TwinSAFE

The axis modules of the AX8000 servo system can be used to implement safe drive technology with third-party motors. Please observe the following notes.

NOTICE

TwinSAFE STO/SS1

The basic TwinSAFE STO/SS1 functions can be used with third-party motors. The connected feedback is not relevant here.

NOTICE

TwinSAFE Safe Motion

The sophisticated TwinSAFE Safe Motion safety functions require the connection of a functional safety encoder (Safe Motion Encoder):

- Hiperface DSL (Functional Safety)
- EnDat® 2.2/22 (Functional Safety)
- EnDat® 3 (Functional Safety)

NOTICE

Non-observance may endanger product safety

If an external encoder is used, the machine builder is responsible for

- the right choice of components
- correct installation in accordance with the encoder operating instructions
- assembling and testing the required encoder connection cable in accordance with the encoder operating instructions
- the FMEDA (Failure modes, effects and diagnostic analysis)

7.12 Forming the capacitors

If the storage period exceeds 5 years, the installed DC link capacitors must be reformed. The following steps must be carried out:

- ▶ Connect mains voltage to the servo drive system
- ▶ Leave the servo drive system connected to the mains voltage for 60 minutes and do not operate under load

The device can then be used as usual.

8 Mechanical installation

8.1 Preparation

⚠ WARNING

Establish voltage-free and de-energized condition

Remove all fuses in the supply network and turn off the main switch on the control cabinet. Secure the control cabinet against being switched on again.

Although a motor is no longer rotating, voltage on the control and power connections or a residual voltage in the capacitors of the servo drive can lead to serious injuries.

NOTICE

Mount servo drives vertically and with sufficient ventilation

Observe the permissible data for operation and environment as well as the notes in this chapter.

Inadequate ventilation and incorrect installation can lead to damage to the servo drive and its components due to heat development.

Note that when dimensioning the control cabinet you may have to mount input filters, mains chokes and braking resistors for your application. Allow sufficient space in the control cabinet for these components so that cooling air circulation is ensured.

8.1.1 Drilling pattern



Beckhoff universal drilling pattern

You have the possibility – at any time and without having to drill new holes – to change the configuration of the servo drive modules if you provide the mounting plate with the universal drilling pattern.

Information is given in the illustration below on how to make tapped holes in the mounting plate in accordance with the drilling pattern.

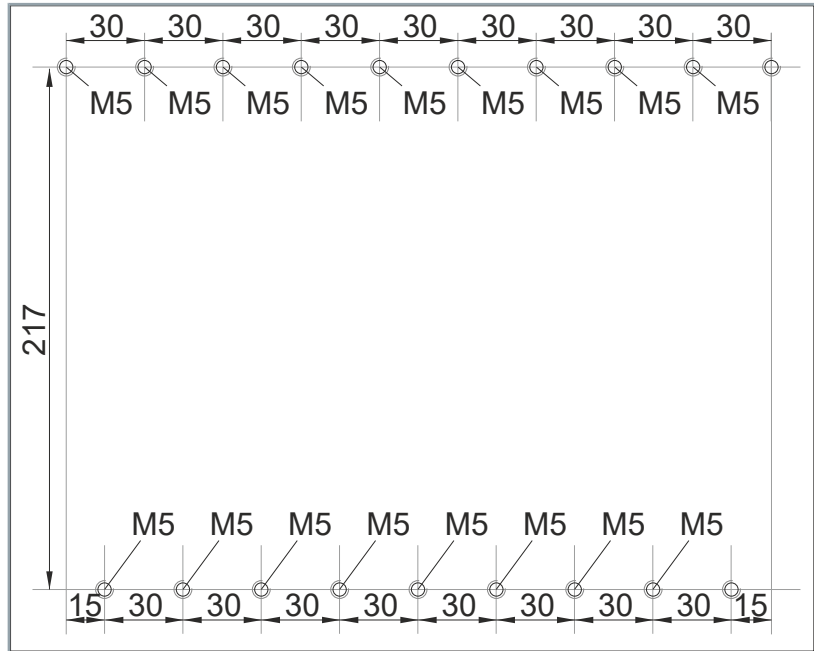

8.2 Modules



Mounting example

This chapter provides information on the mounting of power supply modules and other modules. A power supply module and other axis modules are bayed as an example.

8.2.1 Power supply modules

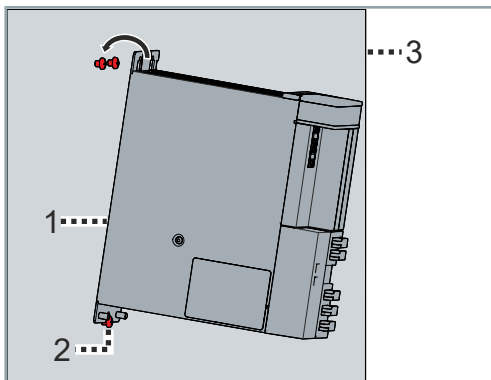

- ▶ Screw screws into the control cabinet mounting plate in accordance with the drilling pattern
- ▶ Place the power supply module [1] onto the screw [2] and carefully press against the mounting plate [3]

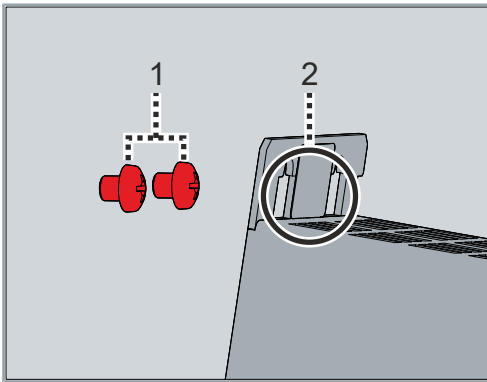

- ▶ Guide the screws [1] through the rectangular cut-outs in the module housing [2]
- ▶ Screw all the screws tight in the elongated holes in the module housing
- ▶ Observe tightening torques:

Components	Tightening torque [Nm]
Screws M5 x 5 Strength class 8.8	6

8.2.2 Axis modules and capacitor modules

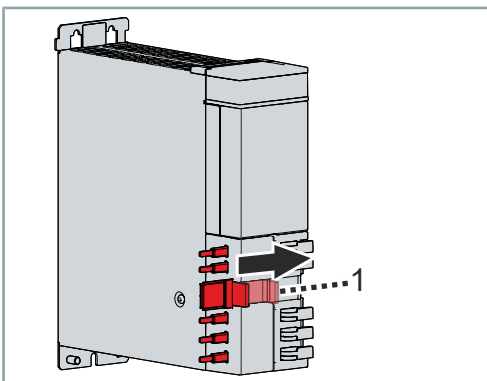

- ▶ On all relevant modules, slide the bar for the AX bridge [1] to the right

The contacts can then no longer be seen.

- ▶ Screw screws once again into the control cabinet mounting plate in accordance with the drilling pattern

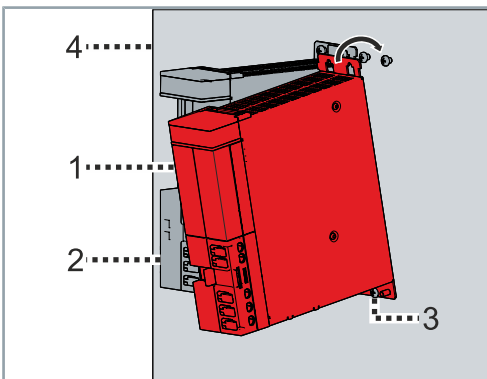

- ▶ Place the axis module [1] at the right side of the power supply module [2] onto the screw [3] and carefully press against the mounting plate [4]

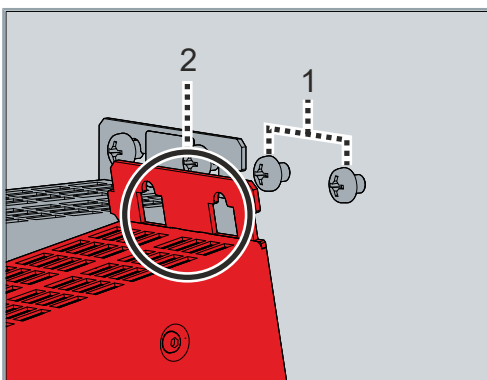

- ▶ Once again, guide the screws [1] through the rectangular cut-outs in the module housing [2]

Mechanical installation

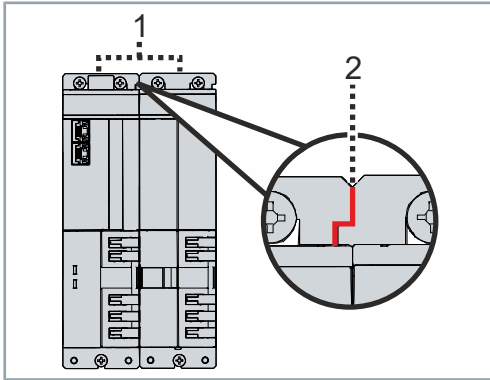

- ▶ Make sure that the plates of the rear panel of Module [1] are not overlapping and that the modules are sitting flush in cut-out [2].

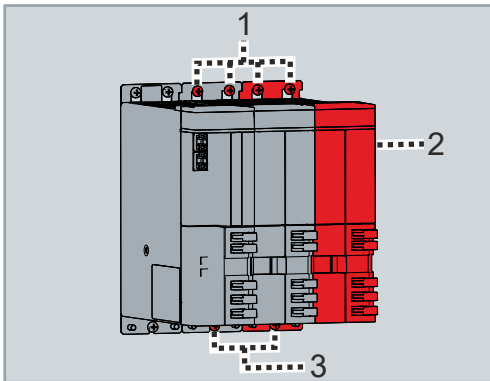

- ▶ Bay further modules [2] and screw all remaining screws [1] and [3] tight on the module housings

- ▶ Observe tightening torques:

Components	Tightening torque [Nm]
Screws M5 x 5 Strength class 8.8	6

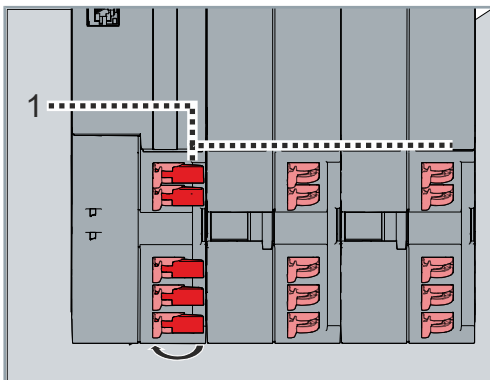

- ▶ On all modules that you wish to connect, open the quick connectors [1] and place them in the 90° position

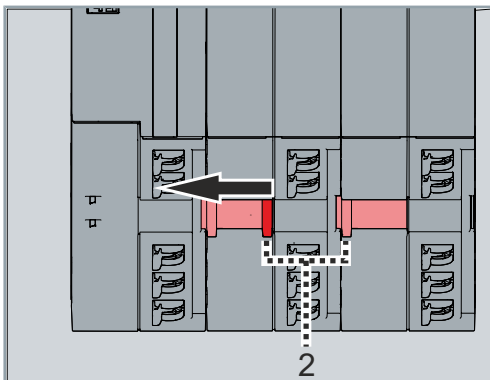

- ▶ Slide all bars [2] for the AX bridge to the left

- ▶ Close all quick connectors again

The modules are now connected to one another.

9 Electrical installation

⚠ WARNING

Avoid contact with DC link DC+ and DC-

Measure the voltage on the DC link test contacts DC+ und DC-. Wait 30 minutes after disconnecting from the mains supply.

There is still a life-threatening voltage of $> 848 V_{DC}$ on the capacitors after disconnection from the supply network. Serious or even fatal injuries may result if this is ignored.

NOTICE

Electromagnetic compatibility

Connect all components and use only shielded cables. Ground the shields of the assembled cables via the mounting plate and place the star point centrally on the unpainted mounting plate.

For larger applications, implement the potential equalization via PE rails.

Improper grounding or faulty contacting can lead to damage to the multi-axis servo system or to EMC interference emissions.

The minimum cross-sections of separate protective conductors can be found in EN 61439-1.

9.1 Project planning

The project planning is the detailed planning of your drivetrain. Taking into account various views, you can design your drive system with the help of the following information. Please note that this support is only an example.

9.1.1 Energy management

If the supply network is impaired due to high voltage fluctuations, you must consider the specifications of the servo drive and the speed range of the servomotor. Observe the upper limit value of the wide voltage input on the AX8000.

Check whether the lowering of the speed due to lacking voltage is permissible.

If the supply network does not correspond to the specification for the operation of the servo drive, then isolating transformers, mains chokes, mains filters or other measures must be added.

This system operates in a drive system with a common DC link and a commonly used internal or external brake resistor. In the case of already existing drive systems, you can determine the utilization rate of the brake resistor with the aid of the diagnostic system and transfer the values. The Beckhoff software "[TE5910 | TwinCAT 3 Motion Designer](#)" is available for energy management purposes.

9.1.2 Control cabinet structure



Observe the voltage tolerances for safe operation

When connecting servomotors with a holding brake, observe the prescribed voltage tolerances.

Observe the order of connection

The nominal current of the device should reduce from the power supply module. Beckhoff recommends the following order of connection of the modules:

- AX8640 – AX8118 – AX8206 – AX8108

You must dimension the control cabinet in such a way that you can install all components with the prescribed spacing.

Forced cooling must be used in case of high temperatures. Place the control cabinet as close as possible to the machine. Dimension the motor cables as short as possible. Apart from that, the control cabinet must have a metallic, grounded rear panel, to which the AX8000 and the peripherals are attached. This makes secure grounding possible.

9.1.3 Drivetrain

The application, servo drives, motors and gear units must be matched to one another so that sufficient safety is ensured for all components. Mechanical stiffness can occur after a while due to wear.

Make sure that the components in the working area of the system have adequate reserves so that the working life is not impaired and the necessary control quality can be maintained.

The Beckhoff software "[TE5910 | TwinCAT 3 Motion Designer](#)" is available for configuration of the drivetrain and selection of suitable components.

9.2 Block diagrams

Sample connection scenarios are presented below using schematic connection diagrams for the power supply modules and axis modules.

9.2.1 AX8600 DC Power supply module

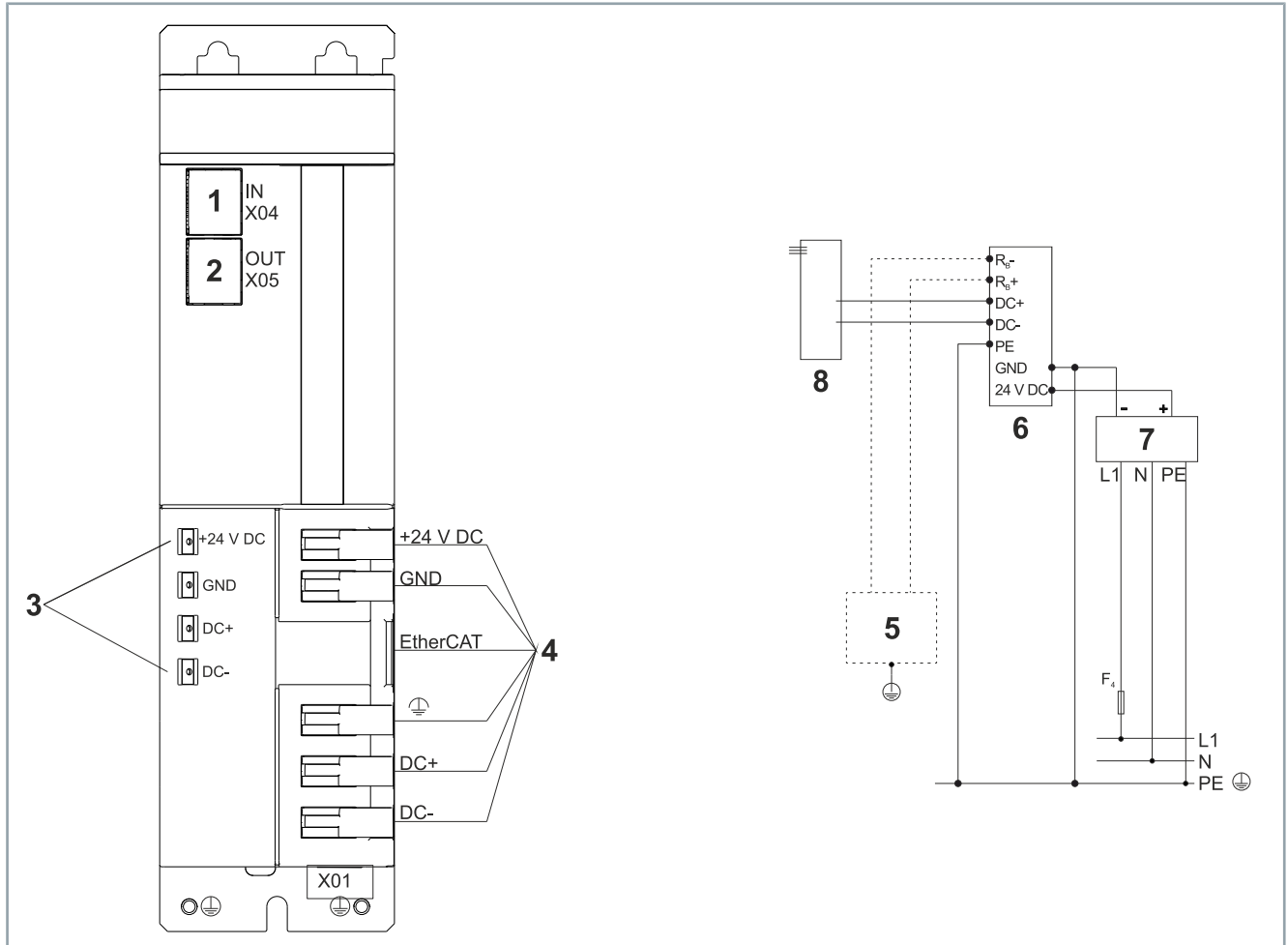

Item number	Explanation
1	Connection socket for incoming EtherCAT cable
2	Connection socket for outgoing EtherCAT cable
3	Measuring and test contacts on the devices
4	Quick coupling of the AX8000 multi-axis servo system; AX bridge
5	Optional braking resistor
6	Schematic contacts on the 7-pin supply plug "X01"
7	Power supply unit with 24 V _{DC} supply voltage
8	ZK4875-900x-zzzz; DC link connection

9.2.2 AX8620 Power supply module 20 A

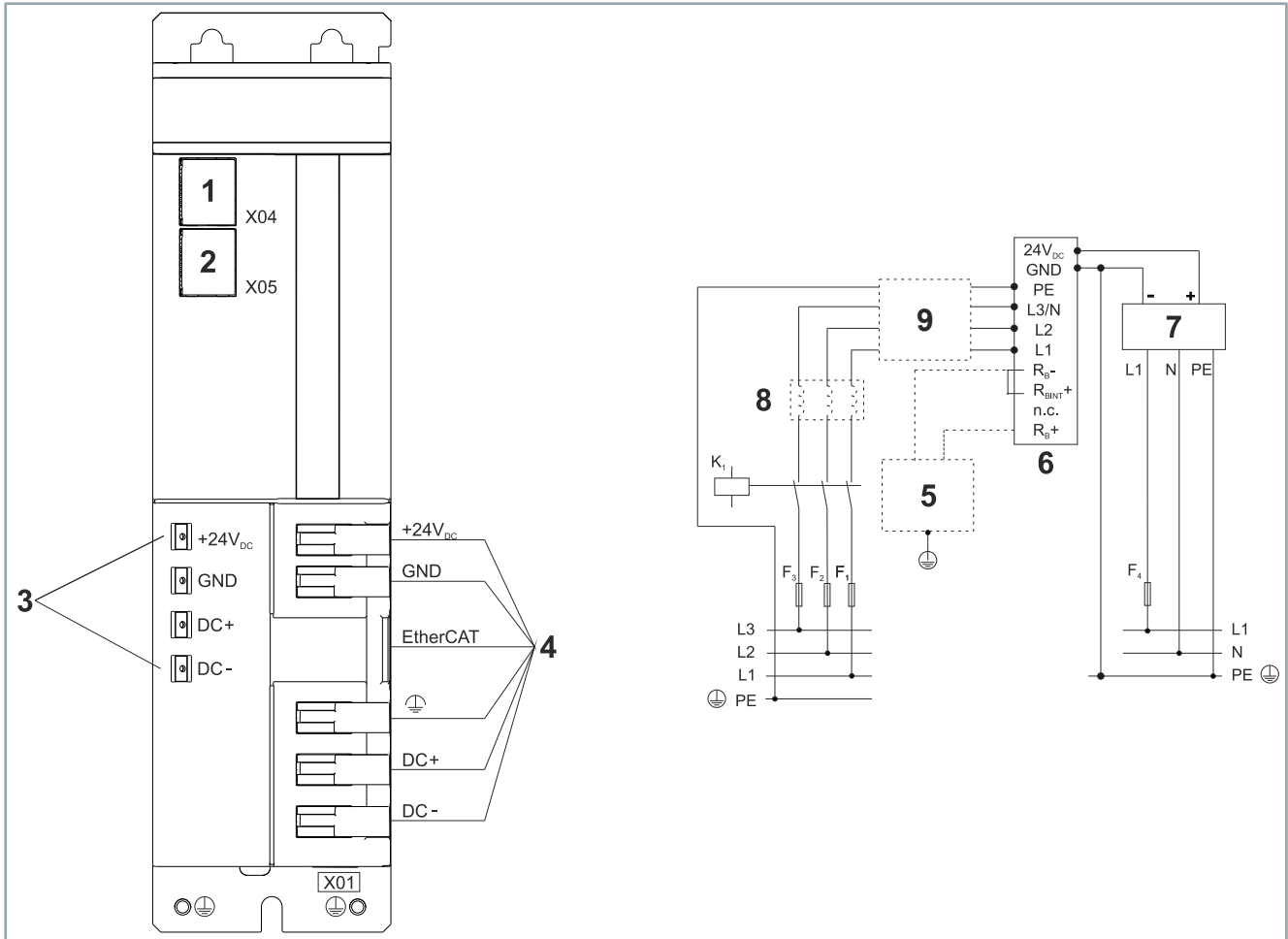

Item number	Explanation
1	Connection socket for incoming EtherCAT cable
2	Connection socket for outgoing EtherCAT cable
3	Measuring and test contacts on the devices
4	Quick coupling of the AX8000 multi-axis servo system; AX bridge
5	Optional braking resistor When using an optional braking resistor on the AX8000 multi-axis servo system, the bridge of the 10-pin supply plug X01 between R _{B-} and R _{Bint+} must be removed
6	Schematic contacts on the 10-pin supply plug X01
7	Power supply unit with 24 V DC supply voltage
8	Optional mains choke
9	Optional mains filter

9.2.3 AX8640 Power supply module 40 A

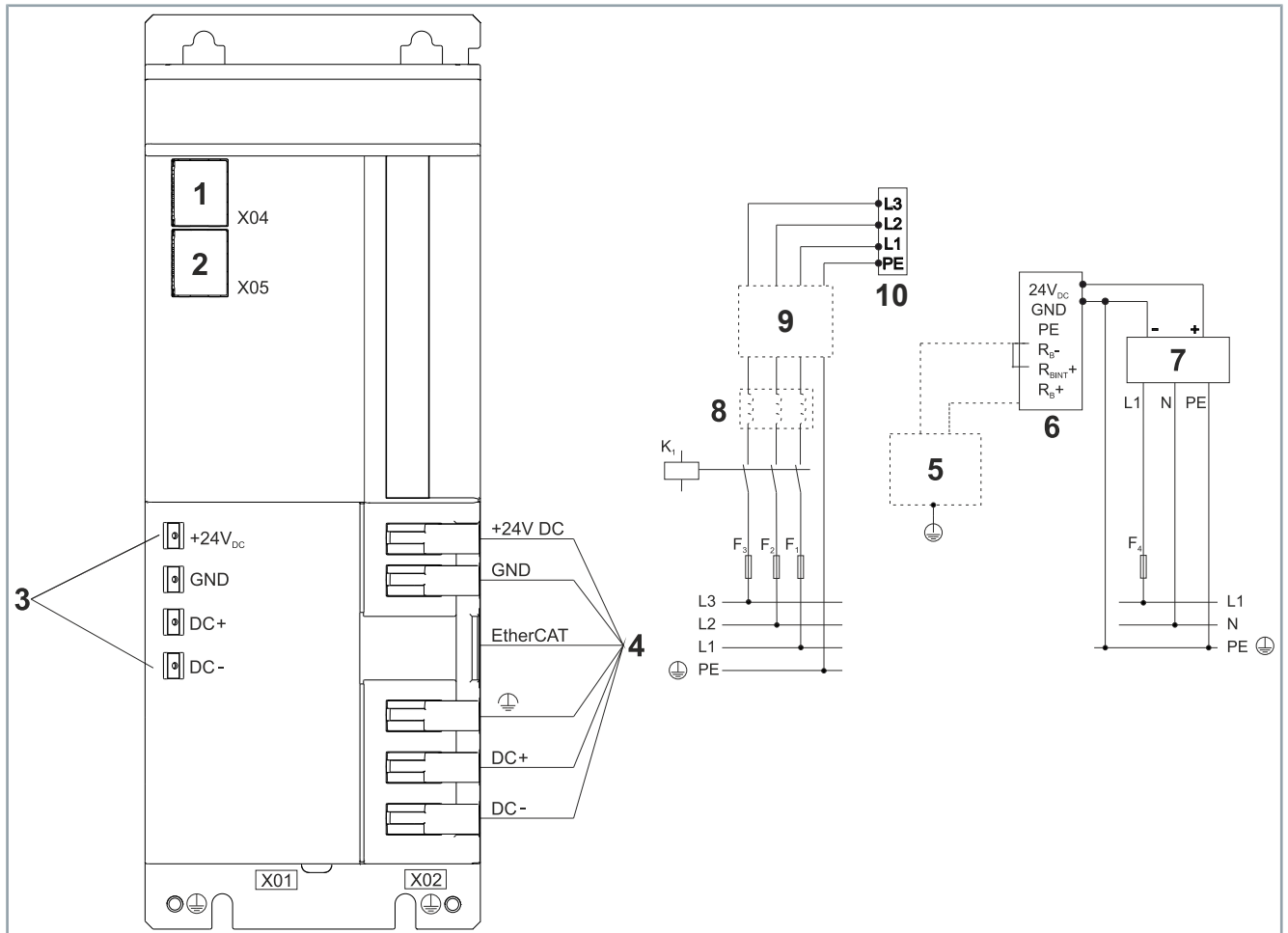

Item number	Explanation
1	Connection socket for incoming EtherCAT cable
2	Connection socket for outgoing EtherCAT cable
3	Measuring and test contacts on the devices
4	Quick coupling of the AX8000 multi-axis servo system; AX bridge
5	Optional braking resistor When using an optional braking resistor with the AX8000 multi-axis servo system, the bridge of the 6-pin supply plug X02 between R_{B-} and R_{Bint+} must be removed
6	Schematic contacts on the 6-pin supply plug "X02"
7	Power supply unit with 24 V DC supply voltage
8	Optional mains choke
9	Optional mains filter
10	Schematic contacts on the 4-pin supply plug X01

9.2.4 AX85xx combined power supply modules and axis modules 25 A, 40 A

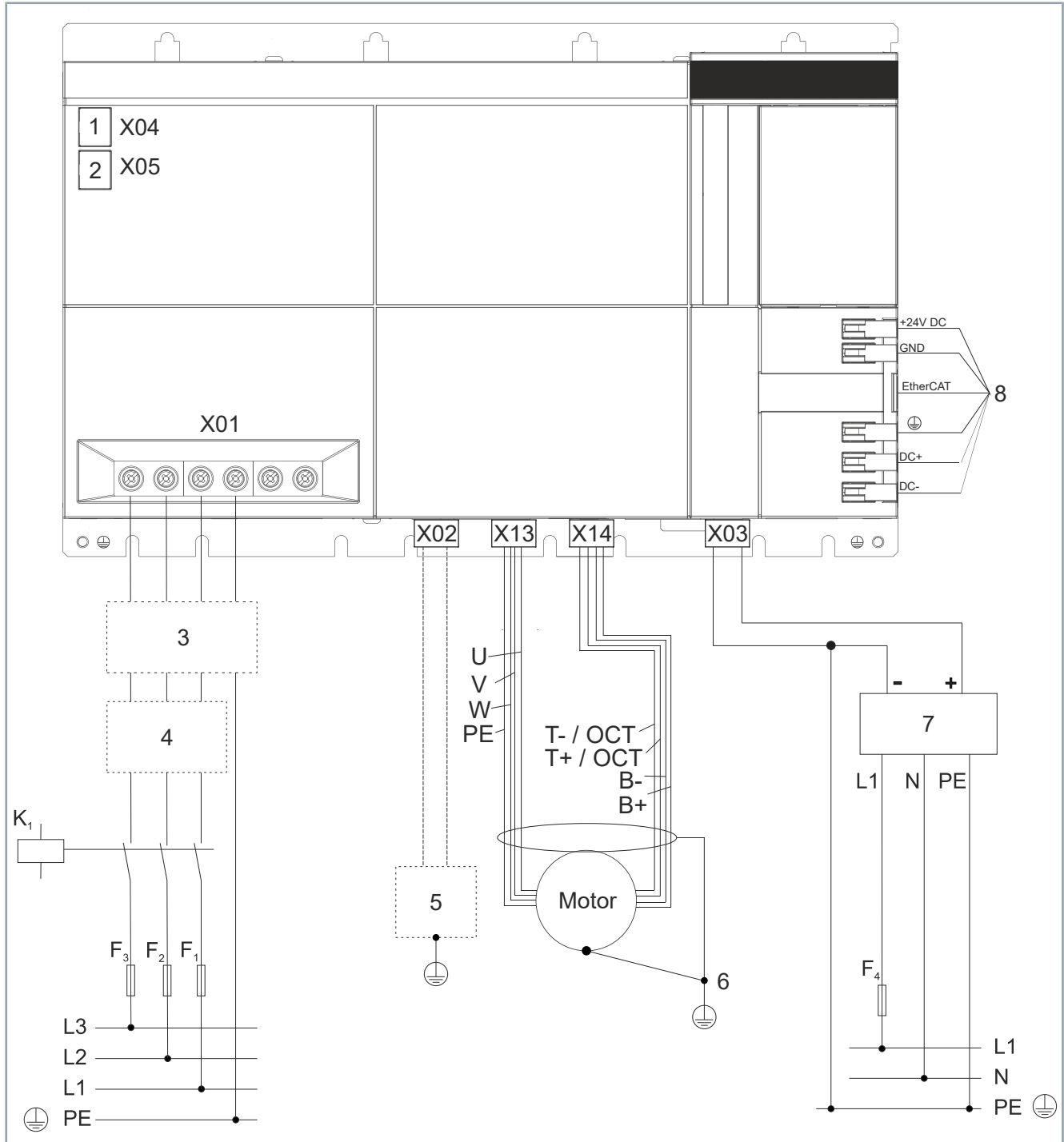

Item number	Explanation
1	Connection socket for incoming EtherCAT cable
2	Connection socket for outgoing EtherCAT cable
3	Optional mains filter
4	Optional mains choke
5	Optional braking resistor When using an optional braking resistor on the AX8000 multi-axis servo system, the bridge of the 4-pin connector plug external braking resistor X02 between R _{B+} and R _{Bint+} must be removed.
6	ZK4800-85xx motor cable; including OCT
7	Power supply unit with 24 V _{DC} supply voltage
8	Quick coupling of the AX8000 multi-axis servo system; AX bridge

9.2.5 AX81x8 single-axis module 8 A, 18 A, 28 A

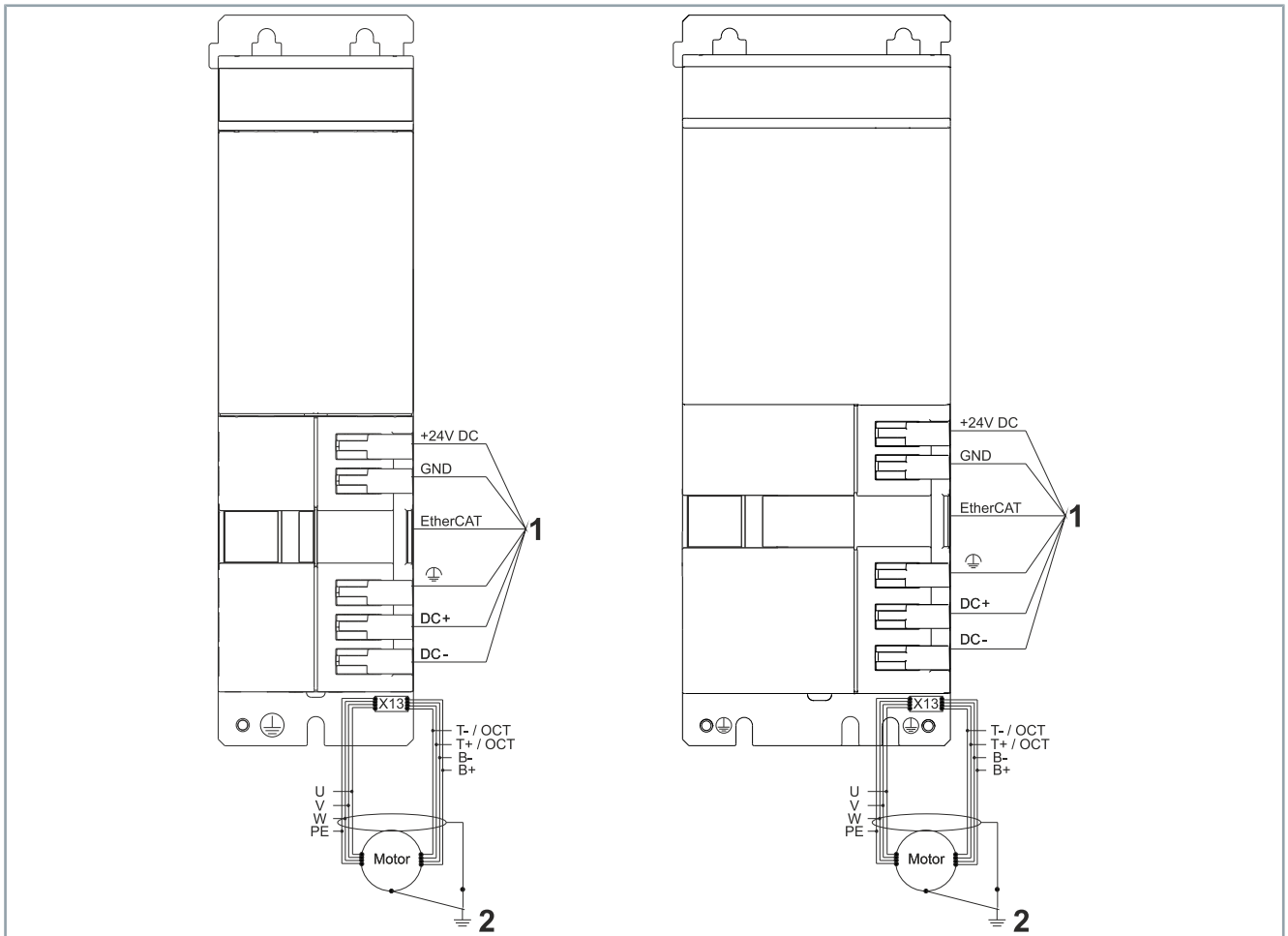

Item number	Explanation
1	Quick coupling of the AX8000 multi-axis servo system; AX bridge
2	ZK4800-8xxx-xxxx motor cable; including OCT

9.2.6 AX8206 Dual-axis module 6 A

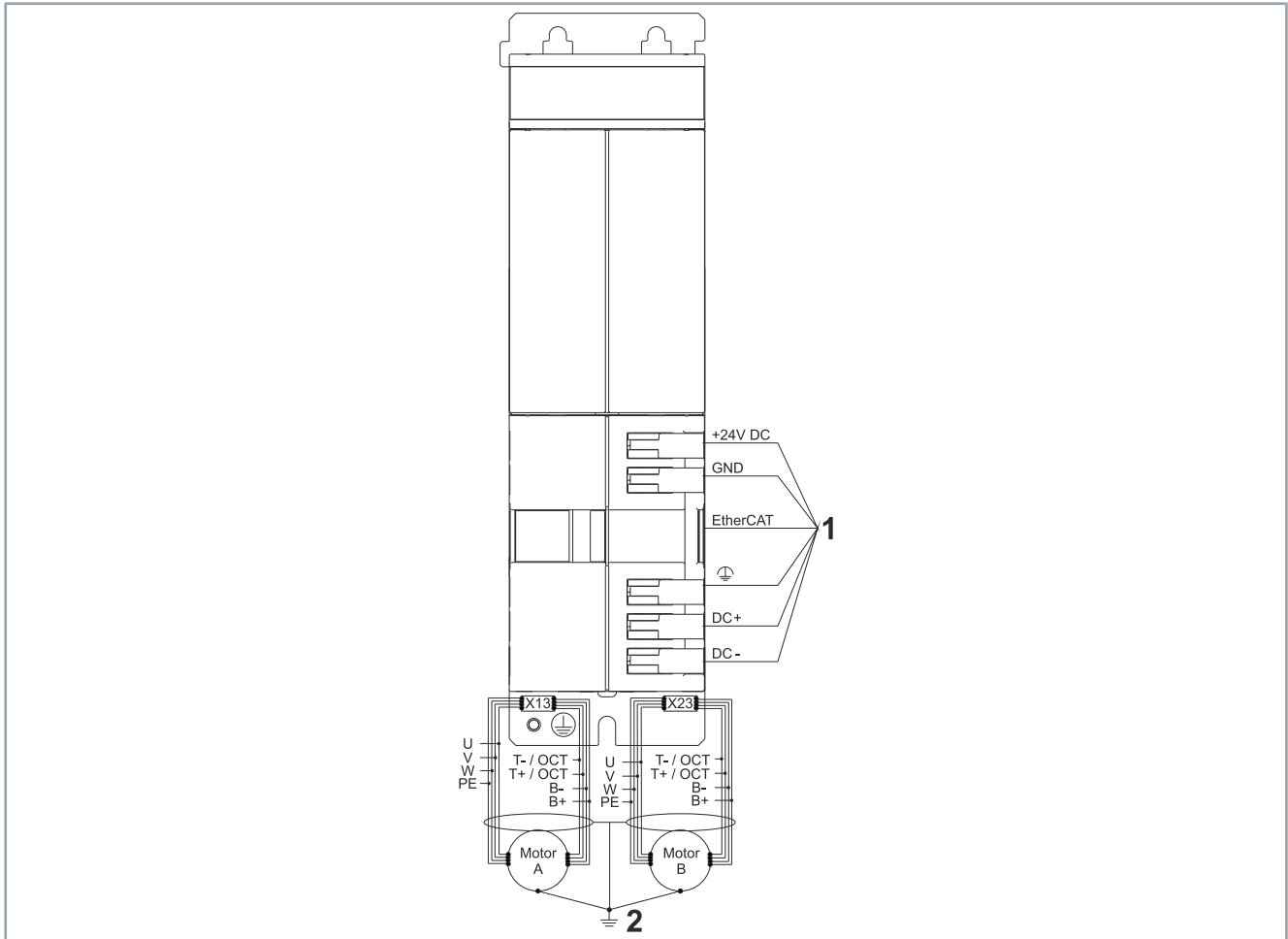

Number	Explanation
1	Quick coupling of the AX8000 multi-axis servo system; AX bridge
2	ZK4800-80xx-xxxx motor cable; including OCT

9.3 Grounding

The ground connection of all relevant components must be executed with the largest possible cross-section, with a low impedance, over a large area and via a short connection to a conductive fastener with a large area. The shields have to be applied with a sufficiently large contact area on both sides.

The earth connection of the AX8000 multi-axis servo system is connected via the grounding hangers and hexagonal nuts, similar to DIN 6923 with class 8 flange and serrations with a galvanized surface. These components are included with all AX8206, AX8118, AX8128 and AX8108 axis modules, all AX8525 and AX8540 combination modules and the AX8810 optional module.

Use of components in a higher EMC category

The AX8000 multi-axis servo system conforms to EMC category C3 for industrial areas with respect to conducted interference emissions. If you wish to use components that conform to a higher category, you can limit the conducted interference emissions using additional filters to the extent that the EMC category C2 for residential and industrial areas is complied with.

Drive system example

In this chapter, the device connection is shown using a multi-axis drive system consisting of an AX8620 power supply module and two AX8206 and AX8108 axis modules.



9.3.1 Module connection

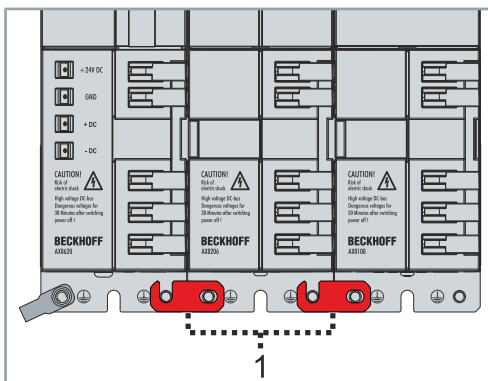

The connection of the individual modules in a drive system takes place via the grounding hangers [1]. These are each mechanically locked to the right-hand earthing bolt of the module and swiveled onto the left-hand earthing bolt of the adjacent module, where they are mechanically locked by the nuts and serrations.

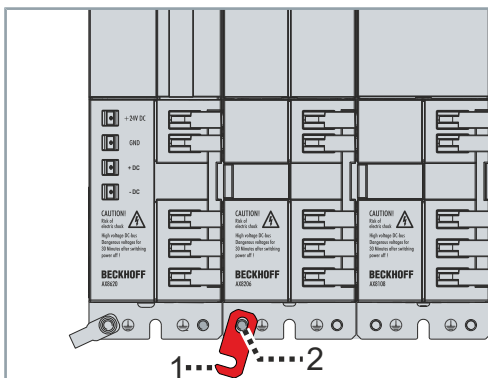

- ▶ Push the grounding hanger [1] onto the earthing bolt [2] of the right-hand module
- ▶ Make sure that the opening in the grounding hanger [1] is facing upwards

Electrical installation

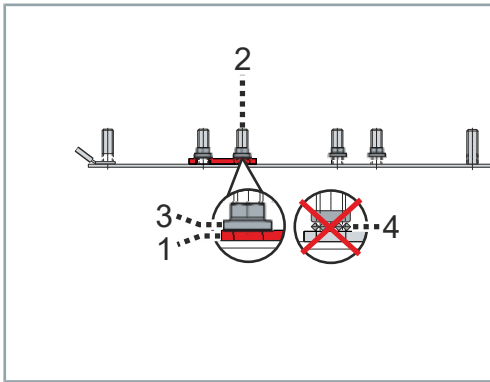

- ▶ Screw the nut [3] onto the earthing bolt [2] on top of the grounding hanger [1]
- ▶ Do not use a spring washer [4]

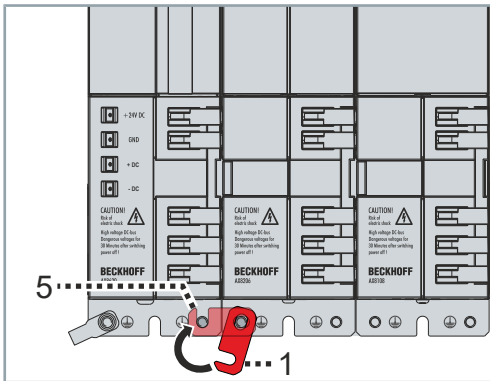

- ▶ Swivel the grounding hanger [1] onto the earthing bolt [5] of the left-hand module

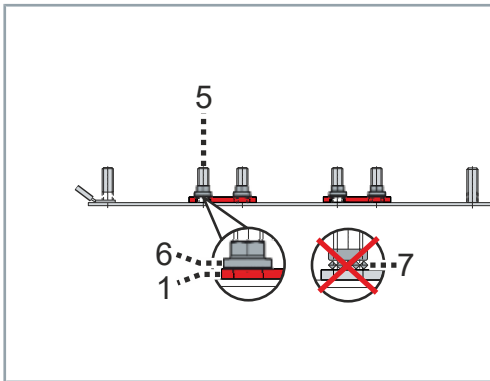

- ▶ Screw the nut [6] onto the earthing bolt [5] on top of the grounding hanger [1]
- ▶ Do not use a spring washer [7]
- ▶ Tighten both nuts firmly
- ▶ Observe tightening torques:

Components	Tightening torque [Nm]
Serrated hexagonal nut M5, strength class A2-50	2.7

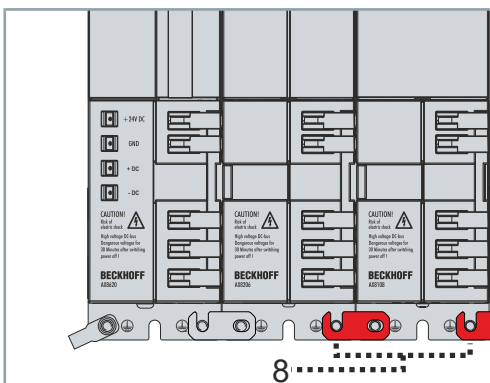

- ▶ Mount [8] further grounding hangers

9.3.2 Protective earth

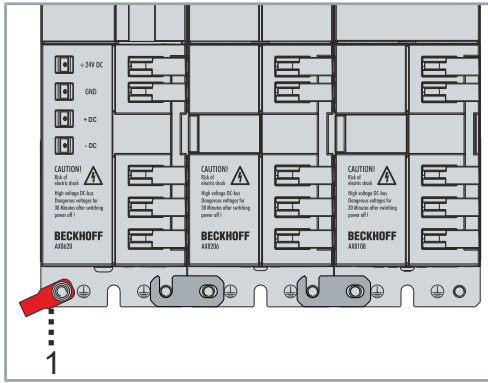

The protective earth is established via the left-hand earthing bolt on the power supply module and the mounting plate on the control cabinet. The connection is made via a cable with a ring-shaped cable lug [1]. Use a cable with a cross-section of at least 10 mm² for a protective conductor.

Optionally, an additional protective earth can be attached via the right-hand earthing bolt of the last module.

- ▶ Make up a cable with a ring-shaped cable lug and a cross-section of at least 10 mm²

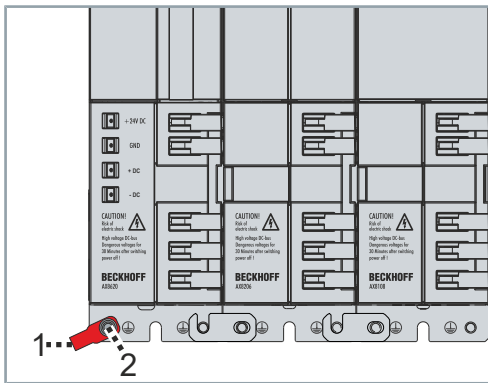

- ▶ Plug the cable with the cable lug [1] onto the left-hand earthing bolt [2] of the first module in the drive system

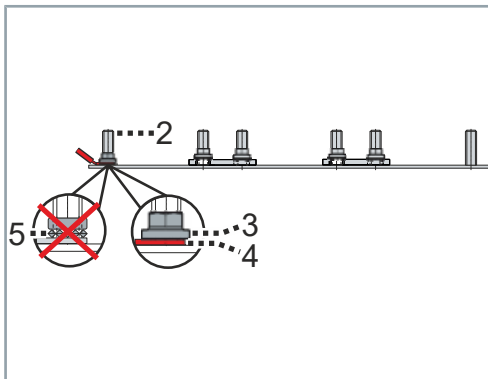

- ▶ Place nut [3] on the earthing bolt [2] on top of the cable lug [4] and screw it tight
- ▶ Do not use a spring washer [5]
- ▶ Observe tightening torques:

Components	Tightening torque [Nm]
Serrated hexagonal nut M5, strength class A2-50	2.7

- ▶ Attach the assembled cable properly to the control cabinet mounting plate. Clean the contact surfaces prior to the assembly and ensure that the mounting plate is not painted.

9.4 Connector power supply 24 V

Supply connections are available on the AX86xx power supply modules and the AX85xx combined modules for the 24 V_{DC} power supply.

Connect the components of the AX8000 multi-axis servo system according to standard EN 60204-1:2006 Protective Extra Low Voltage; PELV:

- The PE and 0 V conductors of the voltage source must be on the same potential and connected in the control cabinet.
- Standard EN 60204-1:2006, section 6.4.1:b stipulates that one side of the circuit, or a point of the energy source for this circuit must be connected to the protective conductor system.

9.4.1 ZS4800-2001 | Connector power supply module AX8620

- X01 slot on AX8620 power supply modules

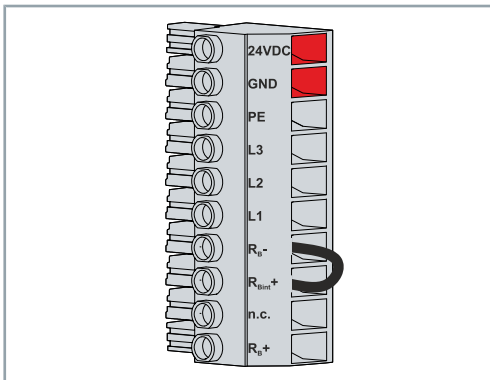

Terminal point	Connection
24 V _{DC}	24 V _{DC} +6/-10 % system voltage and peripheral voltage
GND	GND
Wire cross-section	
Maximum 6 mm ² AWG 8	
Mounting	
Screws with tightening torque 0.5 Nm – 0.6 Nm / 4.4 lbf in – 5.3 lbf in	

9.4.2 ZS4800-2002 | Connector power supply module AX8600

- X01 connection on AX8600 power supply modules

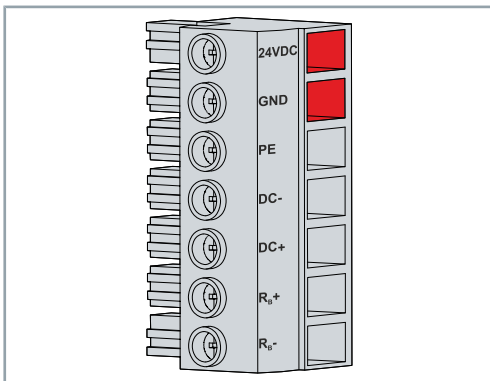

Terminal point	Connection
24 V _{DC}	24 V _{DC} +6/-10 % system voltage and peripheral voltage
GND	GND
Wire cross-section	
Maximum 16 mm ² AWG 6	
Mounting	
Screws with tightening torque 1.2 Nm – 1.5 Nm / 10.6 lbf in – 13.3 lbf in	

9.4.3 ZS4800-2003 | Connector combined modules AX85xx

- X03 connection on AX85xx combined modules

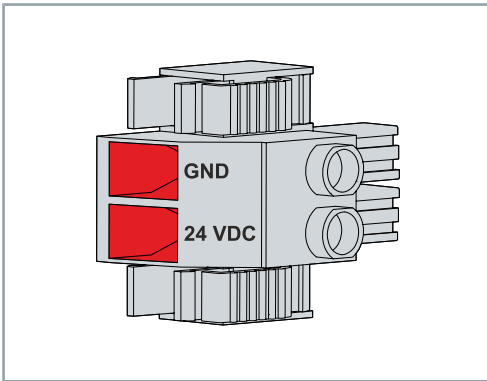

Terminal point	Connection
GND	GND
24 V _{DC}	24 V _{DC} +6/-10 % system voltage and peripheral voltage
Wire cross-section	
Maximum 6 mm ² AWG 8	
Mounting	
Screws with tightening torque 0.5 Nm – 0.6 Nm / 4.4 lbf in – 5.3 lbf in	

9.4.4 ZS4800-2042 | Connector power supply module AX8640

- X02 slot on AX8640 power supply modules

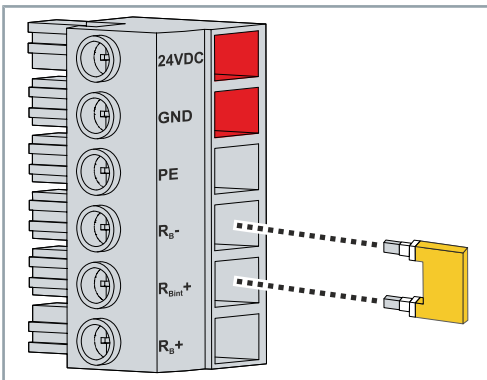

Terminal point	Connection
24 V _{DC}	24 V _{DC} +6/-10 % system voltage and peripheral voltage
GND	GND
Wire cross-section	
Maximum 16 mm ² AWG 6	
Mounting	
Screws with tightening torque 1.2 Nm – 1.5 Nm / 10.6 lbf in – 13.3 lbf in	

9.5 Connector voltage input

NOTICE

Do not remove the bridge between $R_{B_{int+}}$ and R_{B-} .

Proper commissioning is only possible if the bridge between the terminal points $R_{B_{int+}}$ and R_{B-} is not removed. Alternatively, an external brake resistor can be connected.

Without this measure the AX8000 multi-axis servo system will be shut down with an error message.

9.5.1 ZS4800-2001 | Connector power supply module AX8620

- X01 slot on AX8620 power supply modules

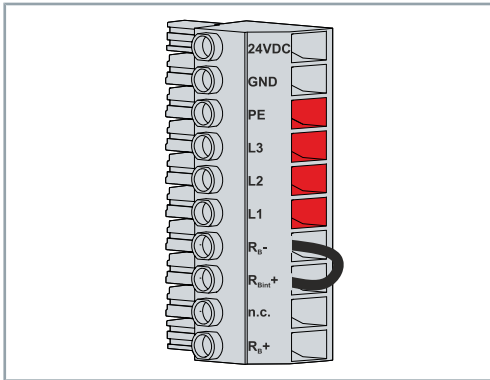

Terminal point	Connection
PE	Protective conductor
L3 / N	Phase L3 / N
L2	Phase L2
L1	Phase L1
Wire cross-section	
Maximum 6 mm ² AWG 8	
Mounting	
Screws with tightening torque 0.5 Nm – 0.6 Nm / 4.4 lbf in – 5.3 lbf in	

9.5.2 ZS4800-2002 | Connector power supply module AX8600

- X02 connection on AX8600 power supply modules

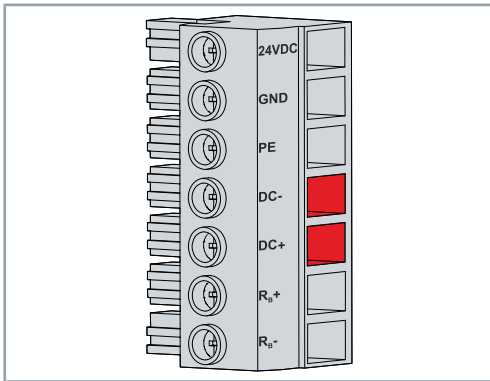

Terminal point	Connection
PE	Protective conductor
DC -	DC link -
DC +	DC link +
Wire cross-section	
Maximum 16 mm ² AWG 6	
Mounting	
Screws with tightening torque 1.2 Nm – 1.5 Nm / 10.6 lbf in – 13.3 lbf in	

9.5.3 ZS4800-2041 | Connector power supply module AX8640

- X01 slot on AX8640 power supply modules

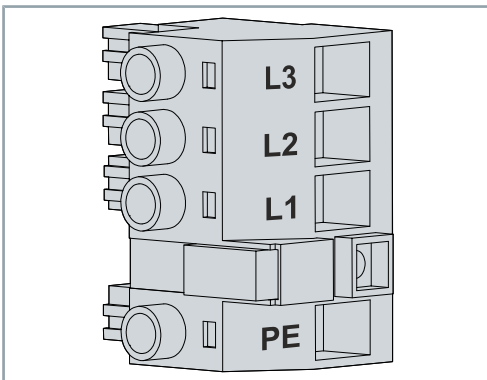

Terminal point	Connection
L3 / N	Phase L3
L2	Phase L2
L1	Phase L1
PE	Protective conductor
Wire cross-section	
Maximum 16 mm ² AWG 6	
Mounting	
Screws with tightening torque 1.2 Nm – 1.5 Nm / 10.6 lbf in – 5.3 lbf in	

9.5.4 Terminal strip on AX85xx

- X01 connection on AX8525 / AX8540 combined modules

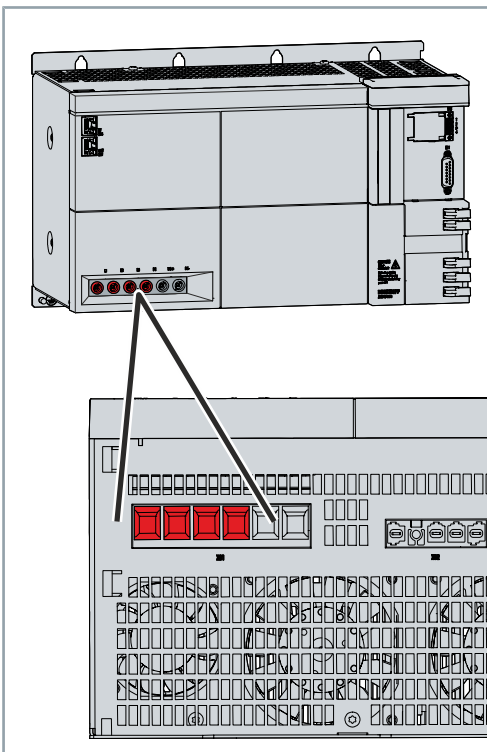

Terminal point	Connection
L1	Phase L1
L2	Phase L2
L3	Phase L3
PE	Protective conductor
Wire cross-section	
Maximum 35 mm ² AWG 2	
Mounting	
Screws with tightening torque 1.2 Nm – 1.5 Nm / 10.6 lbf in – 5.3 lbf in <= 25 mm ² = 2.5 Nm, 35 mm ² = 4.5 Nm	

9.6 Connector external brake resistor



Establish protective earth via connector X02

Connect the "Protective Earth" of the external braking resistor to the PE connection of connector X02.

Various outputs are available on the AX86xx power supply modules and AX85xx combined modules for the connection of an external braking resistor:

9.6.1 ZS4800-2001 | Connector power supply module AX8620



Remove the bridge between contact points R_{B-} and R_{Bint+}

Before you can connect the external braking resistor, remove the bridge between the contacts R_{B-} and R_{Bint+} .

- X01 slot on AX8620 power supply modules

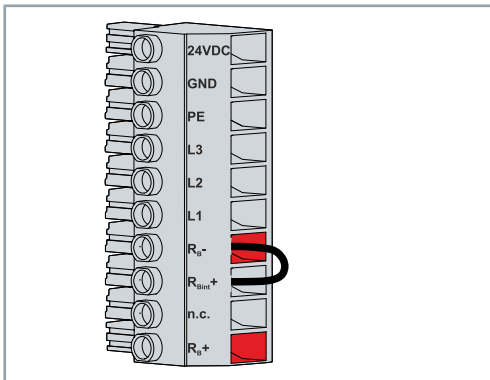

Terminal point	Connection
R_{B-}	Braking resistor -
R_{B+}	Braking resistor +
Wire cross-section	
Maximum 6 mm ² AWG 8	
Mounting	
Screws with tightening torque 0.5 Nm to 0.6 Nm / 4.4 lbf in to 5.3 lbf in	

9.6.2 ZS4800-2002 | Connector combined modules AX8600

- X01 slot on AX8600 combined modules

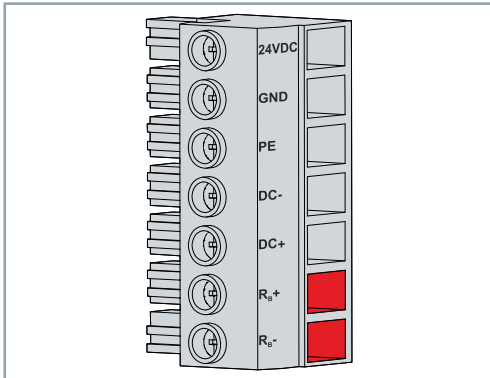

Terminal point	Connection
R_{B-}	Braking resistor -
R_{B+}	Braking resistor +
Wire cross-section	
Maximum 16 mm ² AWG 6	
Mounting	
Screws with tightening torque 1.2 Nm to 1.5 Nm / 10.6 lbf in to 13.3 lbf in	

9.6.3 ZS4800-2042 | Connector power supply module AX8640

**Remove the bridge between contact points R_{B-} and R_{Bint+}**

Before you can connect the external braking resistor, remove the bridge between the contacts R_{B-} and R_{Bint+} .

- X02 slot on AX8640 power supply modules

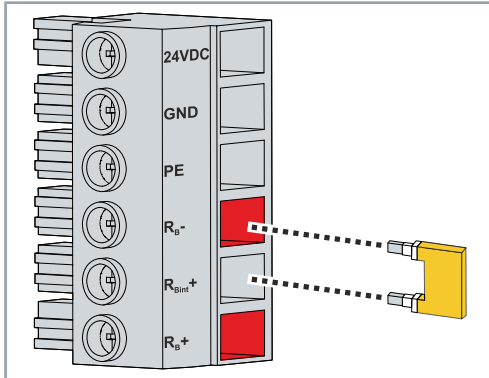

Terminal point	Connection
R_{B-}	Braking resistor -
R_{B+}	Braking resistor +
Wire cross-section	
Maximum 16 mm ² AWG 6	
Mounting	
Screws with tightening torque 1.2 Nm to 1.5 Nm / 10.6 lbf in to 13.3 lbf in	

9.6.4 ZS4500-2047 | Connector combined modules AX85xx

**Remove the bridge between contact points R_{B+} and R_{Bint+}**

Before you can connect the external braking resistor, remove the bridge between the contacts R_{B+} and R_{Bint+} .

- X02 slot on AX85xx combined modules

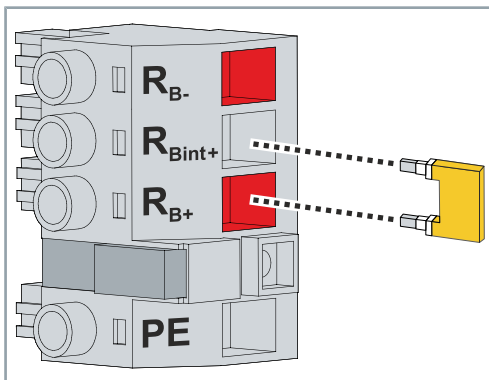

Terminal point	Connection
R_{B-}	External braking resistor GND
R_{B+}	External braking resistor +
Wire cross-section	
Maximum 16 mm ² AWG 6	
Mounting	
Screws with tightening torque 1.2 Nm to 1.5 Nm / 10.6 lbf in to 13.3 lbf in	

9.7 DC link



No external DC link group possible

In order to avoid damaging the AX8000 multi-axis servo system, an external DC link group with a servo drive from the AX5000 series is not permissible.

9.7.1 Terminal strip

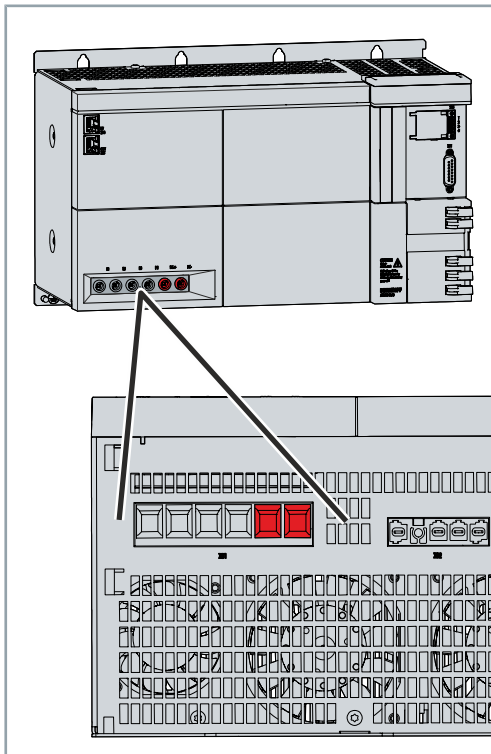

- X01 connection on AX8525 combined modules

Terminal point	Connection
DC+	DC link +
DC-	DC link -
Wire cross-section	
Maximum 35 mm ² AWG 2	
Mounting	
Screws with tightening torque 1.2 Nm – 1.5 Nm / 10.6 lbf in – 5.3 lbf in ≤ 25 mm ² = 2.5 Nm, 35 mm ² = 4.5 Nm	

9.8 Fieldbus system

The EtherCAT real-time Ethernet fieldbus is available in the AX8000 multi-axis servo system.

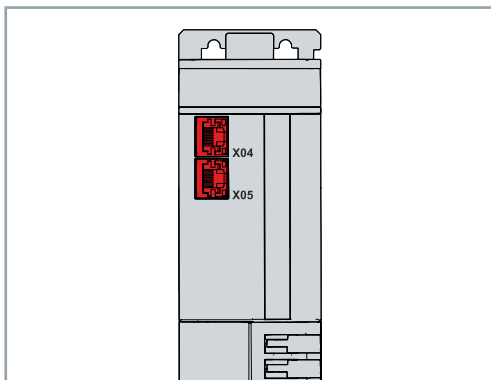

- X04 connection and X05 connection in case of AX8620 and AX8640 power supply modules

Terminal point	Connection
X04 IN	Incoming EtherCAT line
X05 OUT	Outgoing EtherCAT line

9.9 Multi-feedback interface

Encoders with other transfer protocols can be connected to the multi-feedback interface. Only one of the available protocols can be used per module. An overview of the modules and the available protocols can be found under "Multi-feedback interface", [Page 36] in the chapter Ordering option. The multi-feedback interface is available in two versions for the combination modules and axis modules:

- digital feedback protocols:
EnDat[®] 2.2/22 or BiSS[®]C
- digital and analog feedback protocols:
EnDat[®] 2.2/22 or BiSS[®]C or TTL (DIFF RS422) or SinCos 1 Vpp



AL8200-000z-000 Resolution too low

The AL8200-000z-0000 magnetic encoder system with SinCos interface is not supported by the multi-feedback interface due to its low resolution (one sine period per revolution).

9.9.1 Cables and connection of the cable

Definition of connections and slots

X a b	Explanation
X	Designation Connector
a	Channel 1 = channel A 2 = channel B
b	Number of the connector 1 = 1st slot 2 = 2nd slot

Cables and connection of the cable

The following cable is available for the EnDat 2.2/22 feedback system with M12 connection:

- ZK4810-0020-zzzz encoder cable, EnDat 2.2

Connection of the feedback line

- ▶ Remove cover [1]

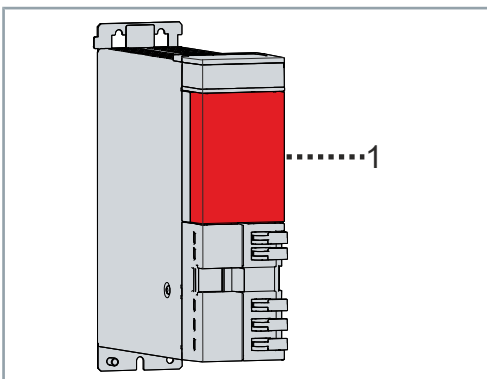

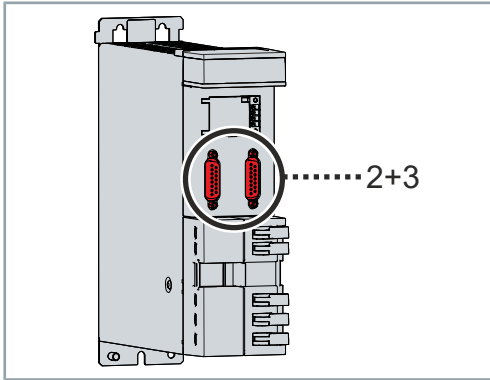

The D-sub connectors [2] and [3] are exposed.

- ▶ Connect feedback

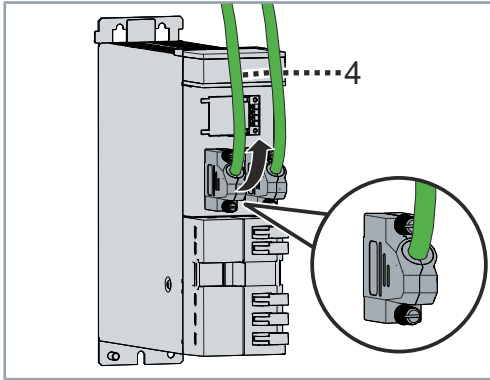

The connectors are angled upwards. If the connectors are connected correctly, the cables can only be guided upwards.

- ▶ Guide cables [4] upwards

9.9.2 AX81xx-0x10 with 2 x D-sub

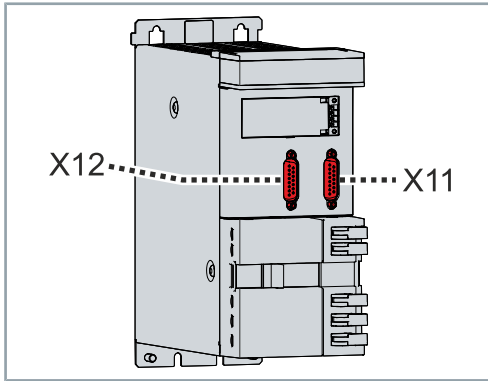

Two D-sub connectors (X11/X12) are available for the AX81xx-0x10 single-axis module:

Typical applications

- as primary feedback, for example as a commutation encoder for linear motors and third-party motors
- as secondary feedback to increase accuracy when OCT is used as primary feedback.

Supported digital feedback protocols:

- EnDat® 2.2/22
- BiSS® C

Pin assignment X11/X12

Pin	EnDat® 2.2/22	BiSS® C
1	n.c.	n.c.
2	GND	GND
3	n.c.	n.c.
4	5 V _{DC} ±10%	5 V _{DC} ±10%
5	Data; DX+ Data	Data+ / SLO+
6	Us 11 V _{DC} ¹⁾	Us 11 V _{DC} ¹⁾
7	n.c.	n.c.
8	Clock; CLK+	CLK+ / MA+
9	n.c.	n.c.
10	GND sense	GND sense
11	n.c.	n.c.
12	5V sense	5V sense
13	Data; DX-	Data- / SLO-
14	n.c.	n.c.
15	Clock; CLK-	CLK- / MA-

¹⁾ When using encoders with 11 V_{DC} supply voltage (pin 6), the sense pins (10 and 12) must not be assigned.

Only one protocol can be set per module.

Maximum output current per D-sub connector: 250 mA

9.9.3 AX81xx-0x20 with 1 x D-sub

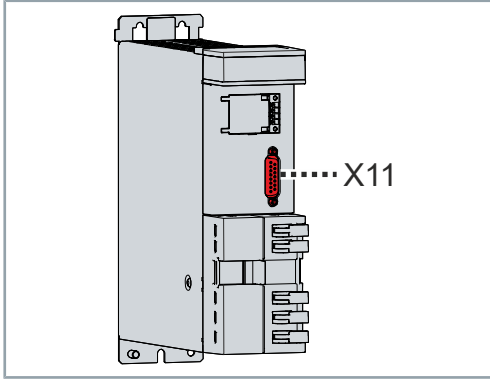

A D-sub connector (X11) is available for the AX81xx-0x20 single-axis modules.

Typical applications

- as primary feedback, for example as a commutation encoder for linear motors and third-party motors
- as secondary feedback to increase accuracy when OCT is used as primary feedback.

Supported digital and analog feedback protocols:

- EnDat® 2.2/22
- BiSS® C
- TTL (DIFF RS422)
- SinCos 1 Vpp

Pin assignment X11

Pin	EnDat® 2.2/22	BiSS® C	TTL (DIFF RS422)	SinCos 1 Vpp
1	n.c.	n.c.	n.c.	SIN
2	GND	GND	GND_5 V	GND_5 V
3	n.c.	n.c.	n.c.	COS
4	5 V _{DC} ±10%	5 V _{DC} ±10%	5 V _{DC} ±10 %	5 V _{DC} ±10 %
5	Data; DX+	Data+ / SLO+	B+	n.c.
6	Us 11 V _{DC} ¹⁾	Us 11 V _{DC} ¹⁾	n.c.	n.c.
7	n.c.	n.c.	REF Z	REF Z
8	Clock; CLK+	CLK+ / MA+	A+	n.c.
9	n.c.	n.c.	n.c.	REFSIN
10	GND sense	GND sense	GND sense	GND sense
11	n.c.	n.c.	n.c.	REFCOS
12	5 V sense	5 V sense	5 V sense	5 V sense
13	Data; DX-	Data- / SLO-	B-	n.c.
14	n.c.	n.c.	Z	Z
15	Clock; CLK-	CLK- / MA-	A-	n.c.

¹⁾ When using encoders with 11 V_{DC} supply voltage (pin 6), the sense pins (10 and 12) must not be assigned.

Only one protocol can be set per module.

Maximum output current per D-sub connector: 250 mA

Cut-off frequency SinCos 1 Vpp: 270 kHz

Cut-off frequency TTL (DIFF RS422): 10 MHz

9.9.4 AX82xx-0x10 with 2 x D-sub

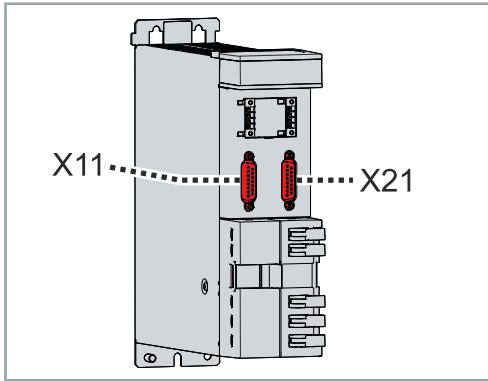

Two D-sub connectors (X11/X21) are available for the AX82xx-0x10 dual-axis module. Each D-sub connector is assigned to one channel.

- Left connector X11: Assignment of axis channel A
- Right connector X21: Assignment of axis channel B

Typical applications

- as primary feedback, for example as a commutation encoder for linear motors and third-party motors
- as secondary feedback to increase accuracy when OCT is used as primary feedback.

Supported digital and analog feedback protocols:

- EnDat® 2.2/22
- BiSS® C

Pin assignment X11/X12

Pin	EnDat® 2.2/22	BiSS® C
1	n.c.	n.c.
2	GND	GND
3	n.c.	n.c.
4	5 V _{DC} ±10%	5 V _{DC} ±10%
5	Data; DX+	Data+ / SLO+
6	Us 11 V _{DC} ¹⁾	Us 11 V _{DC} ¹⁾
7	n.c.	n.c.
8	Clock; CLK+	CLK+ / MA+
9	n.c.	n.c.
10	GND sense	GND sense
11	n.c.	n.c.
12	5 V sense	5 V sense
13	Data; DX-	Data- / SLO-
14	n.c.	n.c.
15	Clock; CLK-	CLK- / MA-

¹⁾ When using encoders with 11 V_{DC} supply voltage (pin 6), the sense pins (10 and 12) must not be assigned.

Only one protocol can be set per module.

Maximum output current per D-sub connector: 250 mA

9.9.5 AX85xx-0x20 with 1 x D-sub

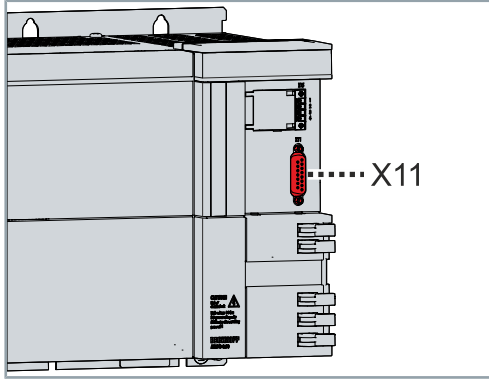

Illustration:

A D-sub connector (X11) is available for the combined AX85xx-0x20 modules:

Typical applications

- as primary feedback, for example as a commutation encoder for linear motors and third-party motors
- as secondary feedback to increase accuracy when OCT is used as primary feedback.

Supported digital and analog feedback protocols:

- EnDat® 2.2/22
- BiSS® C
- TTL (DIFF RS422)
- SinCos 1 Vpp

Pin assignment X11

Pin	EnDat® 2.2/22	BiSS® C	TTL (DIFF RS422)	SinCos 1 Vpp
1	n.c.	n.c.	n.c.	SIN
2	GND	GND	GND_5 V	GND_5 V
3	n.c.	n.c.	n.c.	COS
4	5 V _{DC} ±10%	5 V _{DC} ±10%	5 V _{DC} ±10 %	5 V _{DC} ±10 %
5	Data; DX+	Data+ / SLO+	B+	n.c.
6	Us 11 V _{DC} ¹⁾	Us 11 V _{DC} ¹⁾	n.c.	n.c.
7	n.c.	n.c.	REF Z	REF Z
8	Clock; CLK+	CLK+ / MA+	A+	n.c.
9	n.c.	n.c.	n.c.	REFSIN
10	GND sense	GND sense	GND sense	GND sense
11	n.c.	n.c.	n.c.	REFCOS
12	5 V sense	5 V sense	5 V sense	5 V sense
13	Data; DX-	Data- / SLO-	B-	n.c.
14	n.c.	n.c.	Z	Z
15	Clock; CLK-	CLK- / MA-	A-	n.c.

¹⁾ When using encoders with 11 V_{DC} supply voltage (pin 6), the sense pins (10 and 12) must not be assigned.

Only one protocol can be set per module.

Maximum output current per D-sub connector: 250 mA

Cut-off frequency SinCos 1 Vpp: 270 kHz

Cut-off frequency TTL (DIFF RS422): 10 MHz

9.10 Motor feedback OCT

For the AX8108, AX8118, and AX8206 axis modules, you need a combined motor connector and feedback connector. The connector is part of the preassembled Beckhoff motor cable.

9.10.1 ZS4800-2013 / Connector plug for AX8108 / AX8118 / AX8206 axis modules



Maximum output current for the motor brake B- and B+

AX8108 and AX8206 = 1 A

AX8118 = 2 A

- X13 connection and X23 connection on AX81xx and AX8206 axis modules

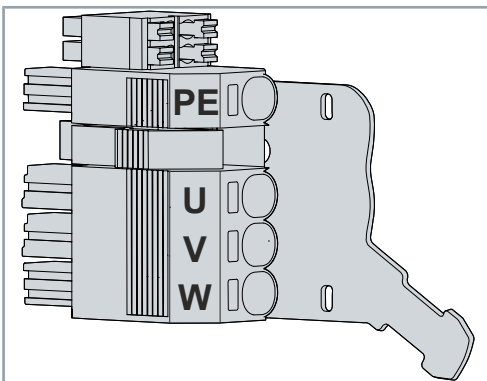

Terminal point	Connection
PE	Protective conductor
U	Motor connection U
V	Motor connection V
W	Motor connection W
T-	OCT- or Temperature - Possible temperature sensors: KTY 83-1xx, KTY 84-1xx, KTY 21-6 or PT1000
T+	OCT+ or Temperature + Possible temperature sensors: KTY 83-1xx, KTY 84-1xx, KTY 21-6 or PT1000
B-	Motor brake GND
B+	Motor brake +
Wire cross-section	
Maximum 6 mm ² AWG 8	
Mounting	
Push in	

NOTICE

Connection of third-party motors

A temperature sensor with double isolation or reinforced isolation is required for the operation of a third-party motor with a temperature sensor on the AX8000.

The AX8000 multi-axis servo system and further components can be damaged if this is ignored.

9.11 AX8128, AX8525, and AX8540 motor connector

A motor connector is required for the AX8128 and the AX85xx combined modules. The connector is part of the preassembled Beckhoff motor cable.

9.11.1 ZS4800-2043 / AX8128 connector plug and AX85xx combined modules

- X13 slot on AX8128 and AX85xx combined modules

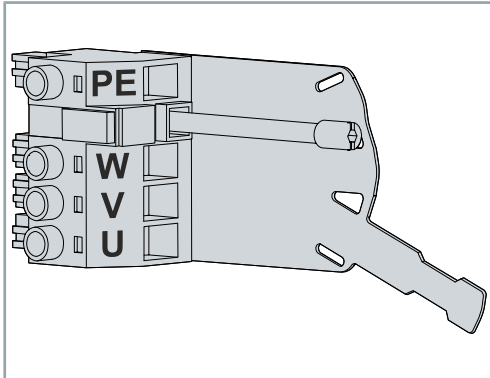

Terminal point	Connection
PE	Protective conductor
W	Motor connection W
V	Motor connection V
U	Motor connection U
Wire cross-section	
Maximum 16 mm ² AWG 6	
Mounting	
Push in	

NOTICE

Connection of third-party motors

A temperature sensor with double isolation or reinforced isolation is required for the operation of a third-party motor with a temperature sensor on the AX8000.

The AX8000 multi-axis servo system and further components can be damaged if this is ignored.



No connection of OCT, temperature sensor and holding brake

The "ZS4500-2014", [Page 113] connector is required to connect the OCT, temperature sensor and holding brake.

9.12 Holding brake / OCT / temperature sensor

9.12.1 ZS4500-2014 / AX8128 connector plug and AX85xx combined modules



Maximum output current for the motor brake B- and B+
AX8128, AX8525 and AX8540 = 2 A

- X14 slot on AX8128 and AX85xx combined modules

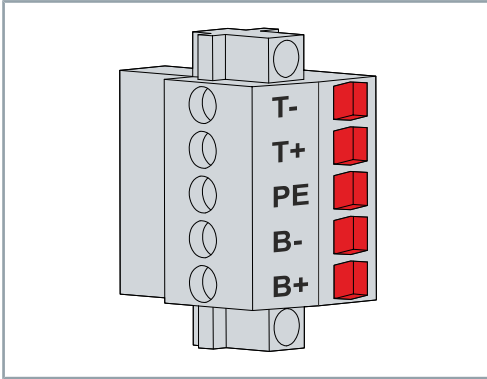

Terminal point	Connection
T-	OCT- or Temperature - Possible temperature sensors: KTY 83-1xx, KTY 84-1xx, KTY 21-6 or PT1000
T+	OCT+ or Temperature + Possible temperature sensors: KTY 83-1xx, KTY 84-1xx, KTY 21-6 or PT1000
PE	Protective conductor
B-	Holding brake GND
B+	Holding brake +
Wire cross-section	
Maximum 6 mm ² AWG 8	
Mounting	
Push in	

NOTICE

Connection of third-party motors

A temperature sensor with double isolation or reinforced isolation is required for the operation of a third-party motor with a temperature sensor on the AX8000.

The AX8000 multi-axis servo system and further components can be damaged if this is ignored.

9.13 Digital inputs

The axis modules have four digital I/Os per axis. The properties of the I/Os depend on the hardware equipment and the TwinSAFE safe drive technology ordering option selected. For single-axis modules, the I/Os are in slot X15. For dual-axis modules, the I/Os are assigned to slots X15 and X25 by channel.

AX8108, AX8118, AX8128, AX8206

A digital input with a hardware-dependent function is available on all four terminal points of the connector.

AX8525 and AX8540

A digital input with hardware-dependent function is available on terminal points 1 and 2 of the devices. Either an input or output is available at terminal points 3 and 4.

9.13.1 ZS4800-2015 I/O connector plug

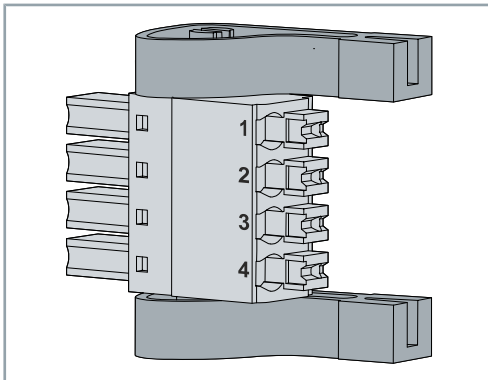

The I/O connector plug ZS4800-2015 is required to connect signals to slot X15 and slot X25. The I/O connector plug is included in the scope of delivery.

9.13.2 Modules without TwinSAFE

Axis modules
 AX8108-x0xx
 AX8118-x0xx
 AX8206-x0xx

Terminal point	Signal type	Input filter
1	digital input	30 µs typ.
2	digital input	30 µs typ.
3	digital input	15 µs typ.
4	digital input	15 µs typ.

Cable	
Configuration	Ferrule with collar according to DIN 46 228/4
Wire cross-section	1 mm ² max., AWG 17
Mounting	Push in

9.13.3 Modules with TwinSAFE

Axis modules

AX8108-x1xx, -x2xx

AX8118-x1xx, -x2xx

AX8128-x1xx, -x2xx

AX8206-x1xx, -x2xx

Terminal point	Connection	Reaction time/ input filter
1	TwinSAFE input	4 ms typ. (read input, write to E-bus)
2	TwinSAFE input	4 ms typ. (read input, write to E-bus)
3	digital input	15 µs typ
4	digital input	15 µs typ

Cable	
Configura- tion	Ferrule with collar according to DIN 46 228/4
Wire cross- section	1 mm ² max., AWG 17
Mounting	Push in

Combined modules

AX8525-x1xx, -x2xx

AX8540-x1xx, -x2xx

Terminal point	Connection	Reaction time/ input filter
1	TwinSAFE input	4 ms typ. (read input, write to E-bus)
2	TwinSAFE input	4 ms typ. (read input, write to E-bus)
3	digital input	15 µs typ.
	digital output	T _{ON} : 60 µs typ. T _{OFF} 300 µs typ.
4	digital input	15 µs typ.
	digital output	T _{ON} : 60 µs typ. T _{OFF} 300 µs typ.

Cable	
Configura- tion	Ferrule with collar according to DIN 46 228/4
Wire cross- section	1 mm ² max., AWG 17
Mounting	Push in

**Support for safety functions**

Before installing the axis modules with TwinSAFE, read the documentation for the AX8911 for AX8xxx-x1xx or AX8911 for AX8xxx-x2xx TwinSAFE drive option cards.

Original operating instructions | AX8911 for AX8xxx-x1xx

[Direct link to the original operating instructions of the TwinSAFE drive option card for servo drive AX8xxx-x1xx](#)

Original operating instructions | AX8911 for AX8xxx-x2xx

[Direct link to the original operating instructions of the TwinSAFE drive option card for servo drive AX8xxx-x2xx](#)

9.14 Leakage currents

When operating servo drives, operationally related leakage currents occur in various frequency ranges. In addition, it is possible for a smooth DC residual current (ohmic) to be produced after the rectifier. These currents would prevent a residual current circuit breaker (RCCB or RCD) of the type A or AC from tripping. In the event of a fault, therefore, it would be possible for dangerous voltages to be present on the housing parts. The legal regulations in various countries demand the use of AC/DC-sensitive RCDs in three-phase applications. These should have a rated residual current of ≤ 300 mA.



Calculation bases for leakage currents

Note that no exact value is calculated for the leakage currents, but rather the maximum expected value, with associated variance.

The leakage current values given in the table are based on the following:

- original Beckhoff motor cables are used
- shielding and grounding concepts are adhered to

Composition of the maximum total leakage current

The maximum total leakage current is composed of:

- device-dependent fixed part with 50 Hz (single-phase supply) or 150 Hz (three-phase supply)
- variable part that depends on the motor cable length and clock frequency. If no other specifications are applied, the clock frequency is around 8 kHz.

The leakage currents of the individual modules add up.

Leakage currents I_{ABFix} [mA]				
Servo drive	1x 230 V _{AC} ; 50 Hz	1x 240 V _{AC} ; 60 Hz	3x 400 V _{AC} ; 50 Hz	3x 480 V _{AC} ; 60 Hz
AX8108	4.1	4.6	3.5	4.4
AX8118	---	---	4.5	5.6
AX8128	---	---	4.8	5.8
AX8206	4.1	4.6	3.5	4.4
AX8620	7	7.9	4.5	4.4
AX8640	---	---	4.5	4.4

9.15 Supply networks

The AX8000 multi-axis servo system is suitable for operation on grounded single-phase or three-phase networks. The respective network configurations differ by the type of ground connection. For a better understanding, the table below contains examples with the associated meaning:

Network configuration	French term	Meaning
TN	Terre Neutre	Neutral grounding of a point
TT	Terre Terre	Direct grounding of a point
TN-C	Terre Neutre Combiné	Combined neutral grounding: Neutral conductor and protective conductor combined to form PEN conductor
TN-S	Terre Neutre Combiné Séparé	Separate neutral grounding: Separate neutral conductor and protective conductor
IT	Isolé Terre	Isolation of all active parts from ground

Connection to TN or TT networks is possible without further measures.

For all other networks, operation is only possible on isolating transformers. An isolating transformer is a mains transformer that transfers the mains voltage to the secondary winding via an electrical isolation. A star point grounded network is made available with the help of this protective isolation.

The AX8000 power supply modules are equipped with a wide-range voltage input on terminal point X01 and can be connected to the following voltage systems:

- Three-phase 200 V_{AC} to 480 V_{AC}
- Single-phase 100 V_{AC} to 240 V_{AC}

9.15.1 Three-phase connection

9.15.1.1 TN network

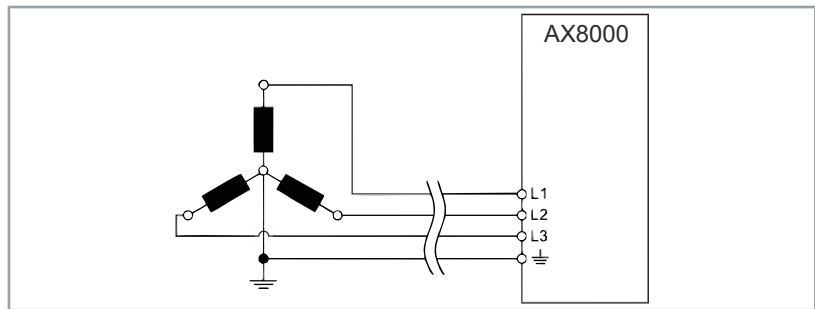

9.15.1.2 TT network

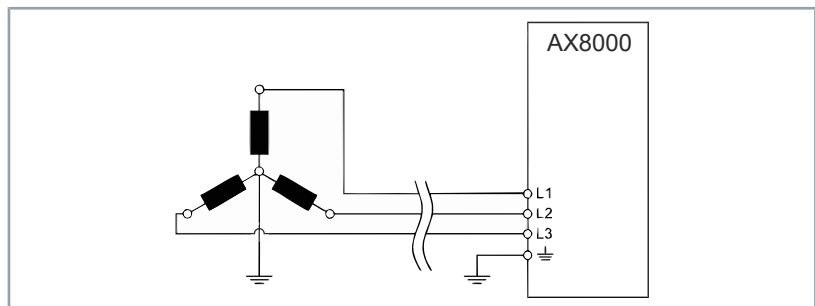

NOTICE

Connection only with upstream isolating transformer

The use of an isolating transformer is generally required for the following grid forms.

Non-compliance may damage the AX8000 multi-axis servo system and the components.

9.15.1.3 Asymmetrically grounded network with star point

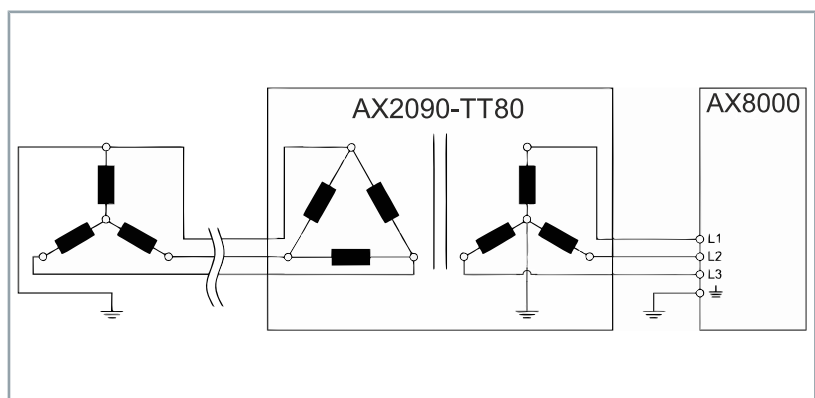

9.15.1.4 Asymmetrically grounded delta network

100...240 V AC

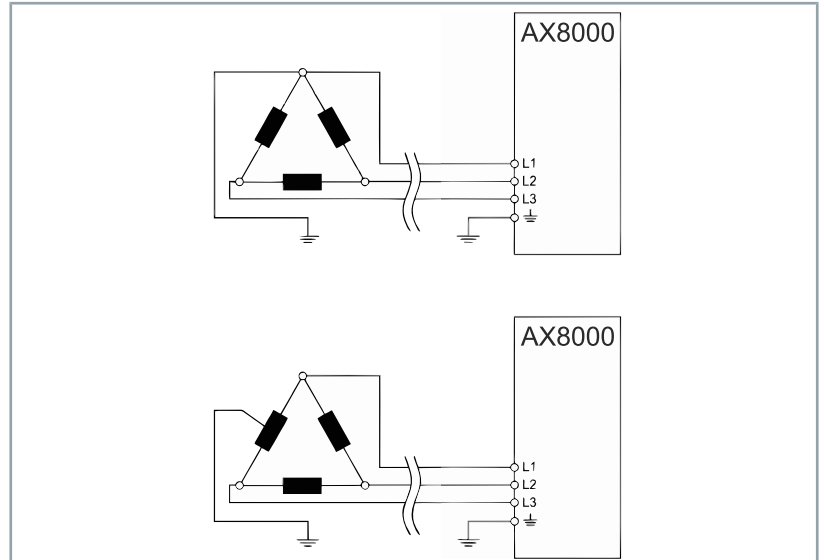

400...480 V AC

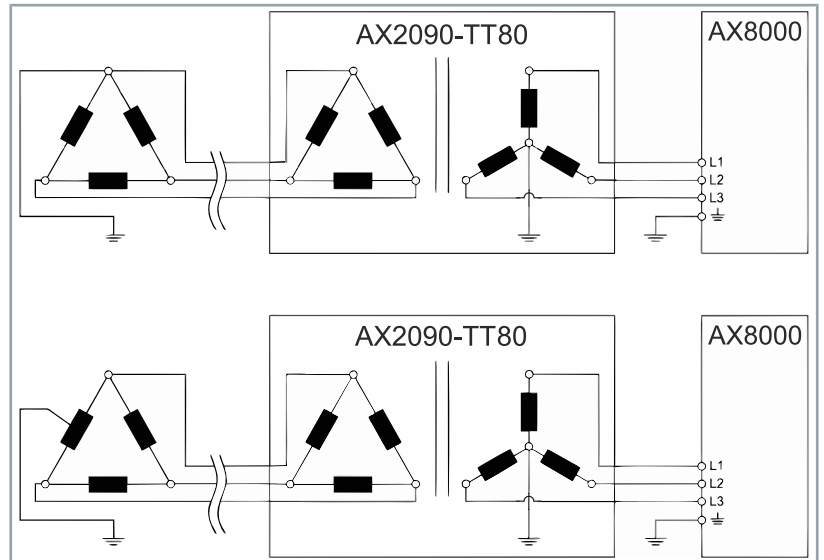

9.15.1.5 IT delta network

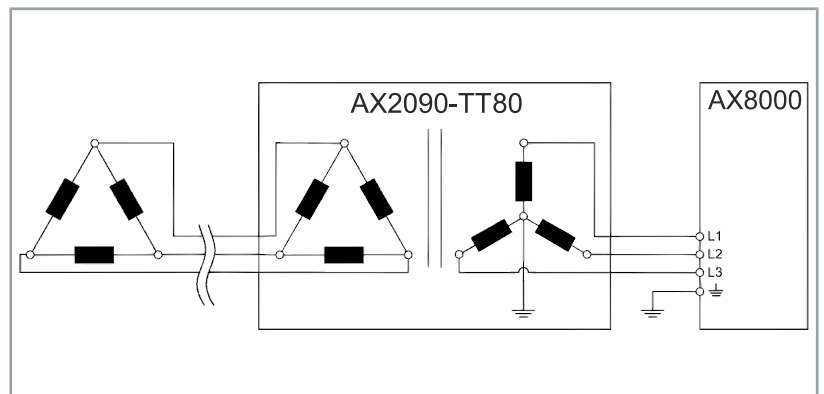

9.15.2 Single-phase connection

9.15.2.1 TN network

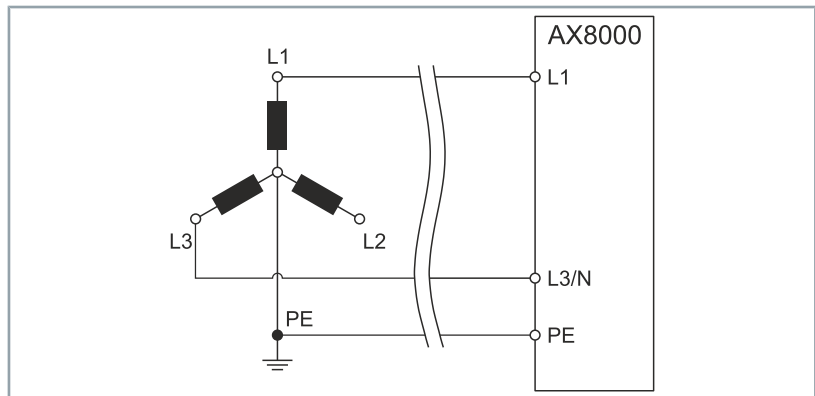

9.15.2.2 TT network

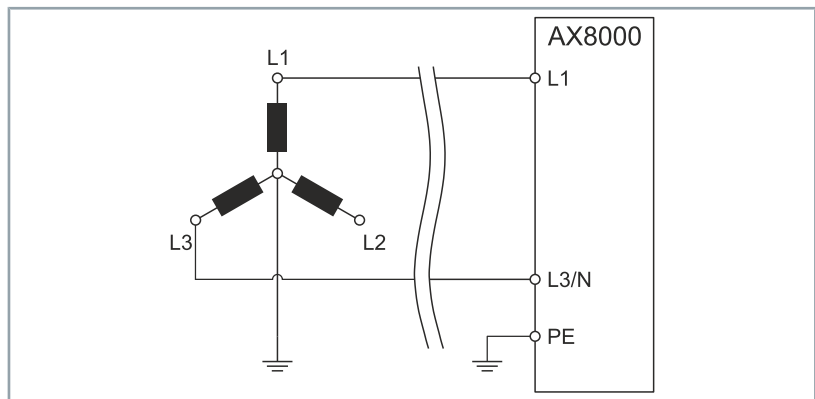

9.15.2.3 TN-C network

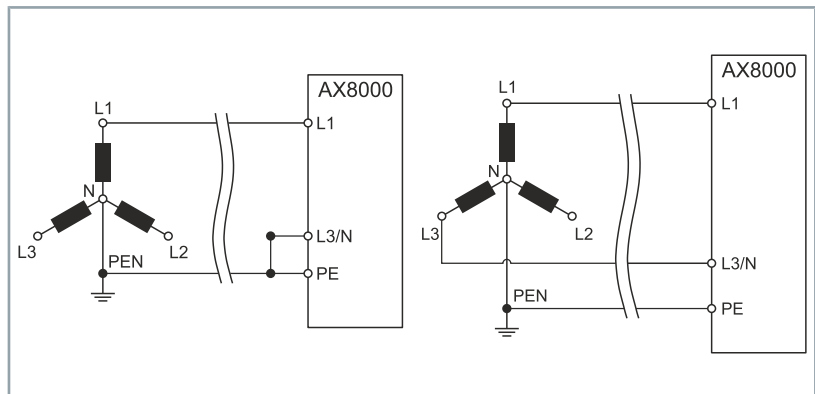

9.15.2.4 TN-S network

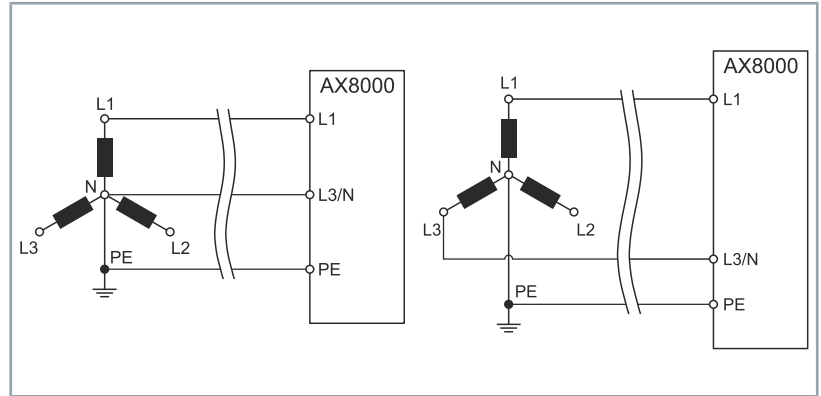

9.15.2.5 Split-phase with grounded center tap 120 V

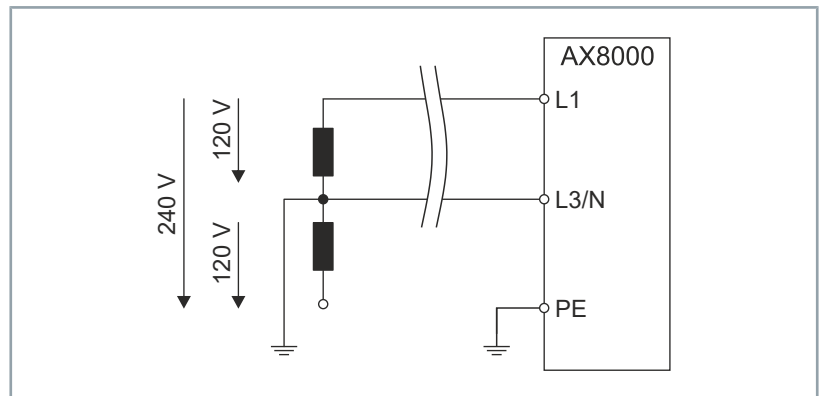

9.15.2.6 Split-phase with grounded center tap 240 V

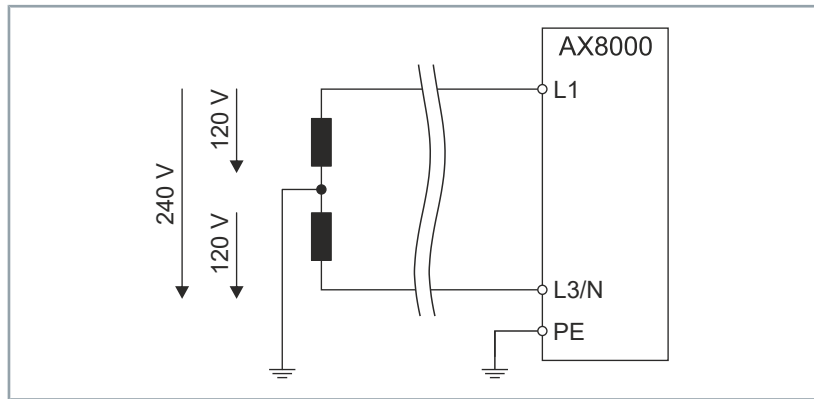

NOTICE

Connection only with upstream isolating transformer

Use an upstream isolating transformer with the following networks.

The AX8000 multi-axis servo system and the components can be damaged if this is ignored.

9.15.2.7 IT network with star point

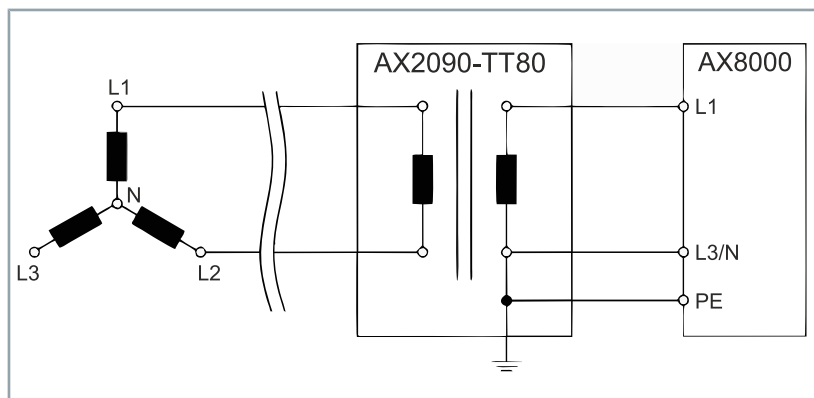

9.15.2.8 IT delta network

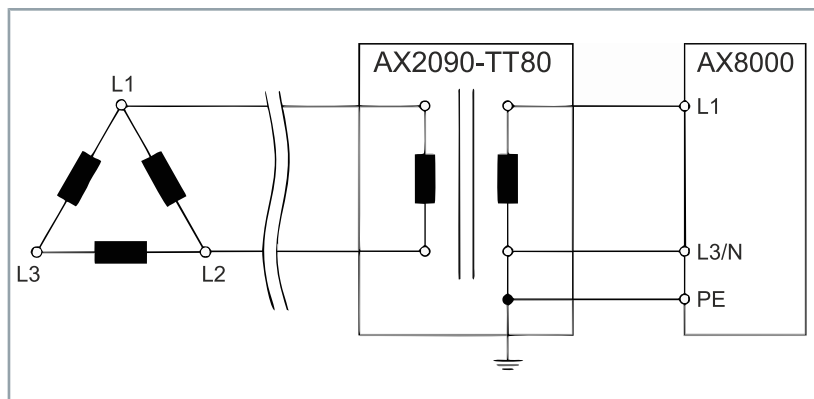

9.15.2.9 Asymmetrically grounded network with star point

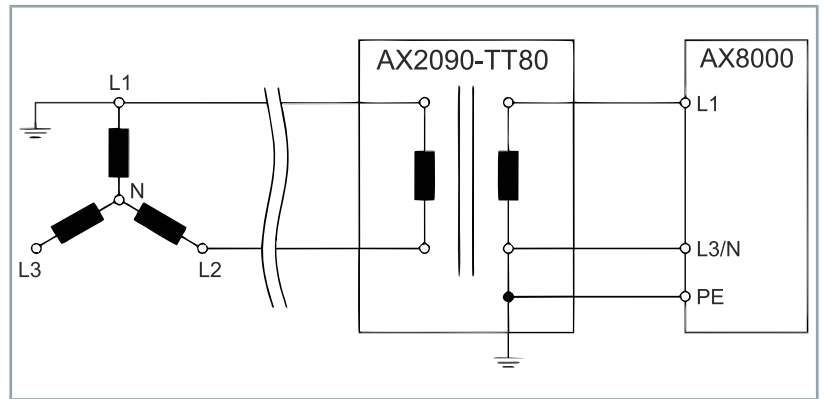

9.15.2.10 Asymmetrically grounded delta network

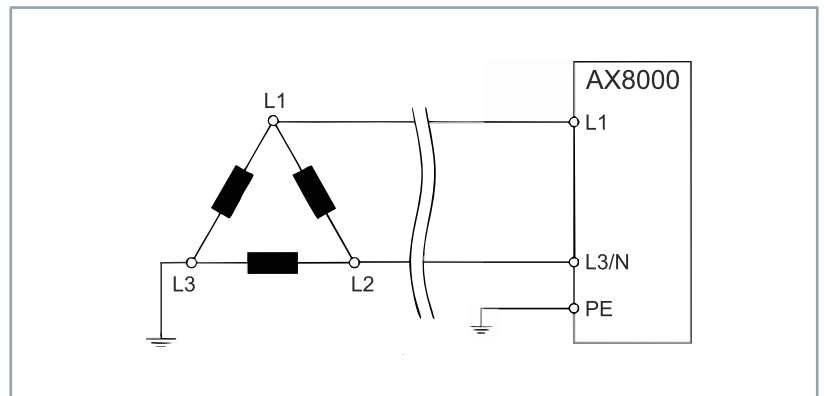

9.15.2.11 Split-phase ungrounded networks

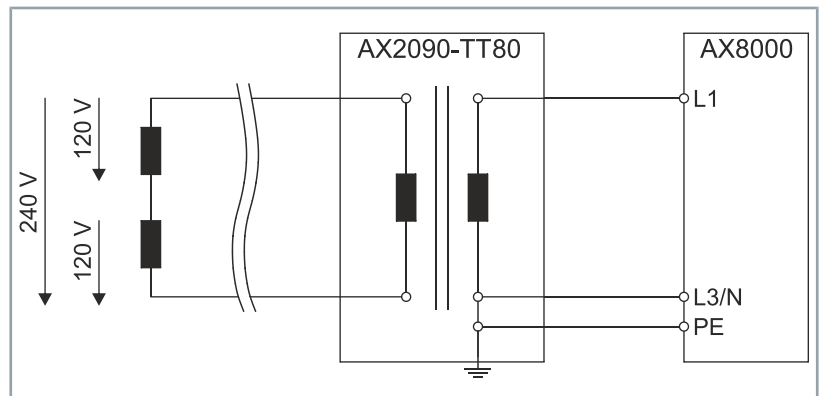

9.15.2.12 DC power supply AX8600

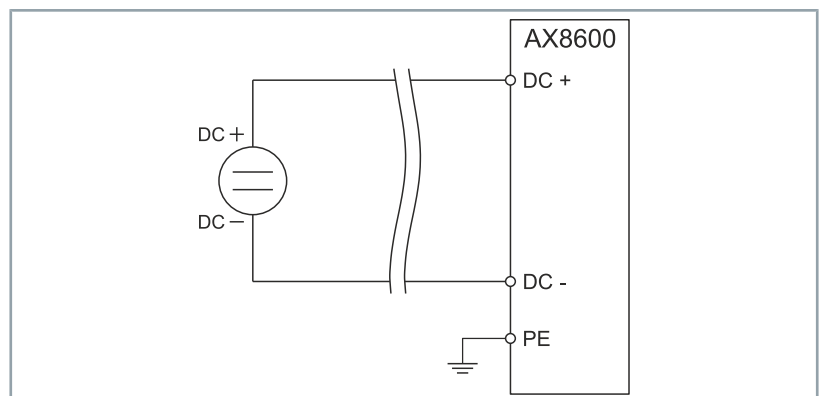

9.15.2.13 DC power supply AX8620

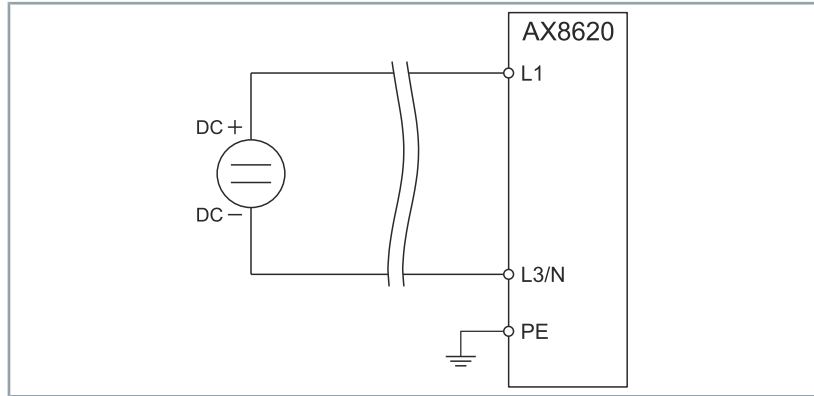

Important: Observe derating!

9.15.3 Isolating transformers

Special network configurations require an upstream isolating transformer. Like the power supply modules of the AX8000, this supplies a short-term peak current of 100%. Full input power is not required for many applications. If this is the case, isolating transformers with a lower power rating can also be used.



Checking the isolating transformer power rating with the TwinCAT 3 Motion Designer

Check the isolating transformer power rating with the design software TE5910 | TwinCAT 3 Motion Designer.

This can be found on the Beckhoff homepage:

- [TE5910 | TwinCAT 3 Motion Designer](#)

The power supply modules are assigned to the isolating transformers in the following tables.

Single-phase supply

Module	Nominal current [A]	Isolating transformer	Nominal current [A]
AX8620	7	AX2090-TT80-0002; 230 V, 1.6 kVA	7

Three-phase supply

Module	Nominal current [A]	Isolating transformer	Nominal current [A]
AX8620	17.5	AX2090-TT80-0010; 400 V, 10 kVA	14.4
AX8640	35	AX2090-TT80-0020; 400 V, 20 kVA	28.9
Full input power			
AX8620	17.5	AX2090-TT80-0016; 400 V, 16 kVA	23.1
AX8640	35	AX2090-TT80-0030; 400 V, 30 kVA	43.4

9.16 Fuse protection

NOTICE

Observe fuses and data for operation and environment

The servo drives are equipped with integrated self-protection. The recommended fuses are used for line protection. Adhere to the dimensioning according to the prescribed data for operation and environment.

The system may be damaged if this is ignored.

9.16.1 CE conform

Depending on the achievable SCCR level, various fuse protection options are available:

9.16.1.1 External fuse protection

Fuse type gG(A)

Use mains fuses of the operating class "gG(A)" according to IEC 60269 or automatic circuit-breakers with the characteristic "C".

Device	Fuse type	max. SCCR
AX8620	gG(A) or Automat "C" max. 25 A	5 kA
AX8640	gG(A) or Automat "C" max. 50 A	5 kA
AX8525	gG(A) or Automat "C" max. 100 A	10 kA
AX8540	gG(A) or Automat "C" max. 100 A	10 kA

Fuse type gG(A) + semiconductor fuse

Semiconductor fuses only serve as short-circuit protection. A mains fuse gG(A) must always be connected in series for line protection. When using semiconductor fuses, be sure to use the exact type specified for the device:

Device	Fuse type	Semiconductor fuse	max. SCCR
AX8620	gG(A) or Automat "C" max. 25 A	Bussmann FWC-32A10F, 10x38 mm, type aR, 32 A	65 kA
AX8640	gG(A) or Automat "C" max. 50 A	Bussmann FWP-63A22F, 22x58 mm, type aR, 63 A	65 kA

Fuse type Circuit breaker

The acceptance test was carried out with Siemens type 3VA5112-6ED31-0AA0. Alternatives to the above types may also be used.

Device	Fuse type	max. SCCR
AX8525	Circuit breaker max. 100 A	65 kA
AX8540	Circuit breaker max. 100 A	65 kA

Protection 24 V DC

Device	Protection
AX8620	20 A
AX8640	20 A

Device	Protection
AX8525	20 A
AX8540	20 A

9.16.1.2 Internal fuse protection

Fuse protection	Fuse
24 V system voltage / periphery	electronic
Internal braking resistor	electronic
External braking resistor	electronic Requirements: <ul style="list-style-type: none">• Active thermal model for selected braking resistor• Correct braking resistor line

9.16.2 UL-compliant

**Fuse holders with UL approval**

Before implementing a UL configuration, it is mandatory that you contact your UL certificate authority and discuss the necessary boundary conditions. When using fuse holders, care must be taken that they have also been tested and manufactured in accordance with the applicable standards of the UL certificate authority.

The integrated protection against short circuit is no substitute for the external mains protection. The protection must comply with the manufacturer's data as well as the national and international regulations and laws.

Use UL mains fuses of the class "J".

For alternatives to the UL fuses of the class "J", be sure to refer to the UL standard "UL 508A, chapter SB4.2.3, exception no.1".

⚠ WARNING

The opening of the branch-circuit protective device may be an indication that a fault current has been interrupted.

To reduce the risk of fire or electric shock, current-carrying parts and other components of the controller should be examined and replaced if damaged.

⚠ AVERTISSEMENT

LE DÉCLENCHEMENT DU DISPOSITIF DE PROTECTION DU CIRCUIT DE DÉRIVATION PEUT ÊTRE DÙ À UNE COUPEURE QUI RÉSULTE D'UN COURANT DE DÉFAUT.

POUR LIMITER LE RISQUE D'INCENDIE OU DE CHOC ÉLECTRIQUE, EXAMINER LES PIÈCES PORTEUSES DE COURANT ET LES AUTRES ÉLÉMENTS DU CONTRÔLEUR ET LES REMPLACER S'ILS SONT ENDOMMAGÉS.

Depending on the achievable SCCR level, various fuse protection options are available:

9.16.2.1 External fuse protection

Fuse type Class J

For alternatives to the UL fuses of the class “J”, be sure to refer to the UL standard “UL 508A, chapter SB4.2.3, Exception No. 1”.

Device	Fuse type	max. SCCR
AX8620	max. 25 A	5 kA
AX8640	max. 50 A	5 kA
AX8525	max. 100 A	10 kA
AX8540	max. 100 A	10 kA

Fuse type Class J + semiconductor fuse



Series connection for effective line protection

Semiconductor fuses only serve as short-circuit protection. A Class J fuse must always be connected in series for line protection.

When using semiconductor fuses, be sure to use the **exact** type specified for the device:

Device	Fuse type	Semiconductor fuse	max. SCCR
AX8620	Class J max. 25 A	Bussmann FWC-32A10F, 10x38 mm, type aR, 32 A	65 kA
AX8640	Class J max. 50 A	Bussmann FWP-63A22F, 22x58 mm, type aR, 63 A	65 kA

Fuse type Circuit breaker

Circuit breakers must have UL approval. The acceptance test was carried out with Siemens type 3VA5112-6ED31-0AA0. Alternatives to the above types may also be used if they are UL approved.

Device	Protection	max. SCCR
AX8525	max. 125 A	65 kA
AX8540	max. 125 A	65 kA

Protection 24 V DC

Device	Protection
AX8620	20 A
AX8640	20 A
AX8525	20 A
AX8540	20 A

9.16.2.2 Internal fuse protection

Fuse protection	Fuse
24 V system voltage / periphery	electronic
Internal braking resistor	electronic
External braking resistor	electronic Requirements: <ul style="list-style-type: none"> • Active thermal model for selected braking resistor • Correct braking resistor line

9.16.3 Device fusing

Conservative

The device fusing can be selected according to various methods:

Select the fusing in accordance with the maximum device fusing of the corresponding power supply module.

Power supply modules	Fuse
AX8620-0000	Maximum 25 A
AX8640-0000	Maximum 50 A
AX8525-0000	Maximum 100 A
AX8540-0000	Maximum 100 A

Application-oriented

Add together the motor currents of all connected servomotors. Multiply the sum by the application-typical simultaneity factor. In the case of a machine tool this is relatively high, e.g. 0.9, because all axes can drive into the material at the same time. In the case of a handling system the factor is more likely to be 0.7.

**Example: handling system with three axes:**

In the following example, a typical use case with a three-axis handling system is described.

The use case is only an example and does not offer the basis for a planned application.

	X	Y	Z
Servomotor	AM8042-0JH0	AM8031-0DH0	AM8021-0BH1
Current	6.90 A	1.95 A	0.85 A

Total sum current: 9.70 A x simultaneity factor 0.7 = 6.8 A

Selected power supply module: AX8620-0000

Selected fuse protection: 10 A



Example of the design of the current-limiting fuses in the system group

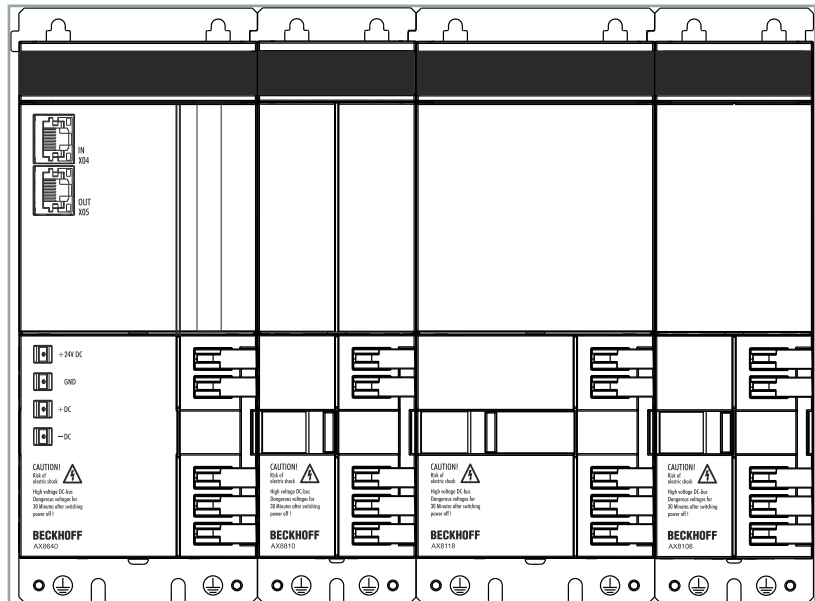

Nominal output current of the axis modules is 18 A for AX8118-0000 and 8 A for AX8108-0000 = 26 A

Total nominal output current = 26 A

The system group must be fused with at least 26 A.

Select the next higher standard level for this according to UL 508A, Tab. SB4.2. This corresponds to class "J" with 40 A.

10 Commissioning



Exemplary commissioning

The procedure for commissioning is described as an example. A different method may be appropriate or necessary, depending on the application of the components.

10.1 Before commissioning

NOTICE

Limited functionality due to unformed capacitors

The dielectric in the DC link capacitors decreases over a very long storage period and the capacitors lose their forming. This can lead to considerable functional restrictions and even a shortened service life of the device.

- If the storage period exceeds 5 years, "reform the capacitors", [Page 81]

Pay attention to the following points before commissioning:

- ▶ Make sure that an emergency stop switch complying with the valid regulations is fitted to the control station
- ▶ Check components for damage
- ▶ Check mounting and alignment
- ▶ Check correct seating of the modules in the control cabinet and on the machine
- ▶ Tighten screw connections correctly
- ▶ Mount mechanical and electrical protective devices
- ▶ Check the wiring, connection and proper grounding

10.1.1 Voltage testing and insulation resistance measurement

Factory testing

All AX8000 series devices are voltage tested in the end of line test in accordance with the requirements for routine testing of product standard 61800-5-1 to prove that air gaps in the basic isolation and reinforced isolation have not been reduced during manufacture.

Testing provided by the customer

AX8000 components may be damaged if the machine or system is tested by the customer!



To protect the components, all device connections must be disconnected before a voltage test or insulation resistance test.

10.2 During commissioning

Pay attention to the following points during commissioning:

- ▶ Check function and adjustment of attachments
- ▶ Observe information for environment and operation
- ▶ Check protective measures against moving and live parts

Configuration

Beckhoff recommends the use of the latest TwinCAT version and the TwinCAT Drive Manager 2 for the configuration of new projects.

- ▶ Create a new TwinCAT project and select the target system
- ▶ Add modules to the I/O devices via the Scan function
- ▶ Create a TwinCAT Drive Manager 2 project
- ▶ Scan components or manually insert a configuration
- ▶ Configure components inserted in the I/O devices
- ▶ Check the state and activate TwinCAT

10.3 Prerequisites during operation

Pay attention to the following points during operation:

- ▶ Listen for atypical noises
- ▶ Check for unusual smoke formation
- ▶ Always check drive surfaces and cables for dirt or dust
- ▶ Check temperature development
- ▶ Observe recommended maintenance intervals
- ▶ Check function of safety devices

10.4 After operation

▲ WARNING

Ensure safe condition of the machine / system

Make sure that all moving parts on the machine come completely to a standstill.

After switching off the power supply, the components of the AX8000 multi-axis servo system may perform uncontrolled movements and cause serious injuries.

11 Maintenance and cleaning

WARNING

Ensure safe condition for cleaning work

Basically, electronic devices are not fail-safe. The condition is always safe when the unit is switched off and not energized. For cleaning work, place the connected servo drives and the machine in a safe state.

Carrying cleaning work during operation can lead to serious or fatal injuries.

NOTICE

Do not immerse or spray the servo drives

Clean the servo drive carefully using only a cloth.

Cleaning by immersion will destroy the servo drive. Impermissible solutions will damage the servo drives and surfaces.

The components of the AX8000 multi-axis servo system are maintenance-free. However, dirt, dust or swarf can negatively affect the function of the components. In the worst case, contamination can lead to failure. Therefore, clean the components regularly and carefully with a cloth or brush.

11.1 Intervals



All modules are maintenance-free

The modules from the AX8000 multi-axis servo system are subject to protection class IP20 and may only be installed and operated in accordance with the "specifications for operation and environment", [Page 41].

Operation beyond the permissible environmental conditions and operating states will shorten the service life of the components of the AX8000 multi-axis servo system.

The service life of consumables may be shortened depending on the mechanical dynamics due to mounted devices and movements.

12 Accessories



Use accessories with UL approval

Accessories with UL approval are also required for the operation of the AX8000 in the USA or Canada.

12.1 Brake resistor

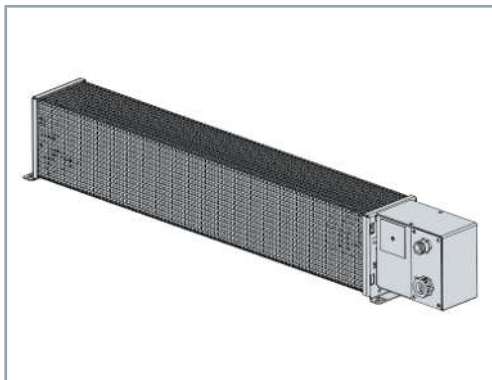

Regenerative energy is converted into heat via the brake resistors of the AX2090-BW80 series when braking a servomotor.

For further information, read the original operating instructions for the brake resistors from the AX2090-BW80-xxxx series.

12.2 Braking resistor IP65

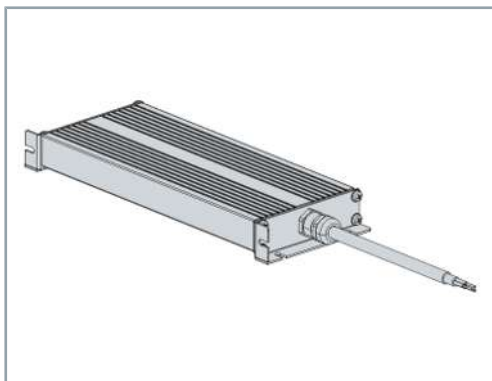

When braking a servo drive, the energy generated is converted into heat by the brake resistors from the AX2090-BW65 series. As components with the protection rating IP65, the braking resistors feature full contact hazard protection and are protected against dust or water jets from any direction.

For further information, read the original operating instructions for the braking resistors from the AX2090-BW65-xxxx series.

12.3 Mains choke

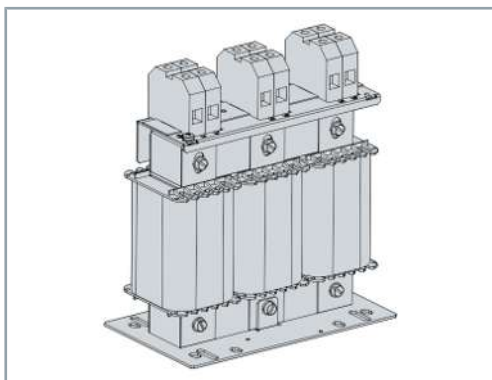

With the help of the mains chokes, current peaks and recharging currents can be limited, for example, for larger servo drives and drive systems.

For further information, read the original operating instructions for the mains chokes from the AX2090-ND80-0xxx series.

12.4 Mains filter

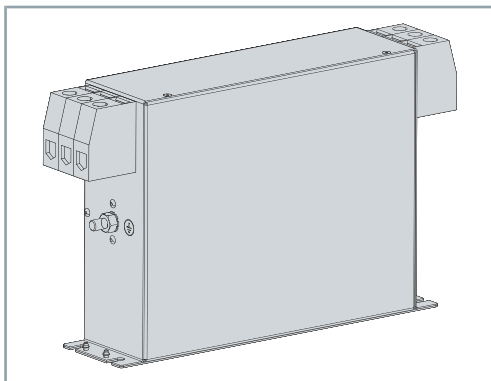

Mains filters are used to comply with the EMC requirements for variable speed drive systems. The requirements are defined in the product standard EN 61800-3. The standard differentiates the requirements according to the installation site:

- First environment
 - Residential buildings and sites where the control cabinet is connected directly, without a transformer, to the public low-voltage network.
- Second environment
 - Industrial areas connected to the medium voltage network via a transformer.

The required category is then derived from this:

- Category C2
 - Stationary drive systems for operation in the first and second environments.
- Category C3
 - Drive systems for operation in the second environment.

The power supply modules of the AX8000 servo system are designed with integrated mains filters for compliance with category C3. Optional mains filters are available for use in the first environment. In addition, a mains choke must be used. The following dependencies on the total motor cable length must be observed:

Power supply module	Category C3	Max. total motor cable length
AX8620 1-phase	Integrated mains filter	up to 300 m without mains choke
AX8620 3-phase	Integrated mains filter	
AX8640	Integrated mains filter	up to 500 m with optional mains choke AX2090-ND80-00xx
AX8525 and AX8540	Integrated mains filter	

Power supply module	Category C2	Max. total motor cable length
AX8620 1-phase	with mains filter AX2090-NF80-0010	up to 300 m
AX8620 3-phase	with mains filter AX2090-NF80-0020 and mains choke AX2090-ND80-0020	up to 500 m
AX8640	with mains filter AX2090-NF80-0040 and mains choke AX2090-ND80-0040	
AX8525 and AX8540	with mains filter AX2090-NF80-0080 and mains choke AX2090-ND80-0080	

13 Decommissioning

Disassembly may only be carried out by qualified and trained personnel.

Refer to chapter Documentation notes.

When disposing of electronic waste, make sure that you dispose of it in accordance with the regulations applicable in your country. Read and follow the instructions for proper disposal.

13.1 Disassembly

WARNING

Avoid contact with DC link DC+ and DC-

Measure the voltage on the DC link test contacts DC+ und DC-. Keep to the waiting times after disconnection from the supply network:

- **30 minutes** for AX8620 and AX8640
- **30 minutes** for AX8108, AX8118, AX8128, and AX8206

There is still a life-threatening voltage of $> 848 V_{DC}$ on the capacitors after disconnection from the supply network. Serious or even fatal injuries may result if this is ignored.



Do not remove components from the products

Only Beckhoff Automation GmbH & Co. KG is permitted to remove components.

Contact Beckhoff Service for further information.

Removal of the servo drive from the machine

- Remove cables and electrical connections
- Loosen and remove the servo drive fixing screws

13.2 Disposal

Depending on your application and the products used, ensure the professional disposal of the respective components:

Cast iron and metal

Dispose of cast and metal parts as scrap metal for recycling.

Cardboard, wood and foam polystyrene

Dispose of packaging materials made of cardboard, wood or foam polystyrene in accordance with the regulations.

Plastics and hard plastics

You can recycle parts made of plastic and hard plastic via the recycling depot or re-use them depending on the component designations and markings.

Oils and lubricants

Dispose of oils and lubricants in separate containers. Hand over the containers at the used oil collection station.

Batteries and rechargeable batteries

Batteries and rechargeable batteries may also be marked with the crossed-out trash can symbol. You must separate these components from the waste and are legally obliged to return used batteries and rechargeable batteries within the EU. Observe the relevant provisions outside the area of validity of the EU Directive 2006/66/EC.



Electronic components

Products marked with a crossed-out waste bin must not be disposed of with general waste. Electronic components and device are considered as waste electrical and electronic equipment for disposal. Observe the national regulations for the disposal of old electrical and electronic equipment.

14 Guidelines and Standards

14.1 Standards

Generic standards EN IEC 61000-6-2

"Immunity standard for industrial environments"

Generic standards EN IEC 61000-6-4

"Emission standard for industrial environments"

Product standard EN IEC 61800-3

"Adjustable speed electrical power drive systems. EMC requirements and specific test methods"

EN IEC 63000

"Technical documentation for the assessment of electrical and electronic products with respect to the restriction of hazardous substances"

EN IEC 61800-5-1

"Adjustable speed electrical power drive systems"

Part 5-1: Safety requirements - Electrical, thermal and energy

IEC 61800-5-3

"Adjustable speed electrical power drive systems"

Part 5-3: Safety requirements - Functional, electrical and environmental requirements for encoders

14.2 Guidelines

2014/35/EU

Low Voltage Directive

2011/65/EU

RoHS Directive

2014/30/EU

EMC Directive

Regulation (EU) 2021/821

Dual-use regulation



Installation with protective conductor connection

When installing electrical systems and components, the protective conductors must be connected first. They must be disconnected last when uninstalling.

Depending on the magnitude of the leakage currents, observe the following regulations for the implementation of the protective conductor connection:



- Minimum requirement for protective conductor: KU value of 4.5
- The minimum requirement for leakage currents: $I_L < 10 \text{ mA}$; $KU = 6$ for $I_L > 10 \text{ mA}$

Value	Explanation
KU	Variable for the classification of safety-related types of failure for protection against dangerous shock current and excessive heating
KU = 4.5	Achieved in relation to interruption: With permanently connected protective conductor connection $\geq 1.5 \text{ mm}^2$ With protective conductor connections $\geq 2.5 \text{ mm}^2$ via connector for industrial plants according to IEC 60309-2
KU = 6	Achieved in relation to interruption: With permanently connected conductors $\geq 10 \text{ mm}^2$; the type of connection and routing must comply with the standards applicable to PE conductors

14.2.1 Electrical isolation

The power section, consisting of motor connection, DC link connection and mains connection, as well as the control unit are to be double-insulated against each other. This guarantees secure shock protection on all terminals in the control unit, even without further measures. The air gaps and creepage distances conform to EN 50178 / VDE 0160.

14.3 Test centers

	<p>The product AX8000 multi-axis servo system does not fall within the area of applicability of the Machinery Directive.</p> <p>However, Beckhoff products are designed and evaluated for personal safety and use in a machine or system in full compliance with all relevant regulations.</p>
	<p>The product AX8000 multi-axis servo system meets all requirements of the British Economic Area. These include England, Wales, and Scotland.</p>
	<p>The product AX8000 multi-axis servo system meets the requirements according to UL and is UL-listed. This applies to the US and Canadian market in accordance with the standards applicable in the USA and Canada.</p> <p>The cURus logo can be found on the name plate.</p>

14.4 EU conformity



Provision

Beckhoff Automation GmbH & Co KG will be pleased to provide you with EU declarations of conformity and manufacturer's declarations for all products on request. Send your request to:

✉ info@beckhoff.com

14.5 UL certification

The modules may be used as components in a system with a UL-Listing test mark.

Further information can be found in the chapter Fuse protection under "UL-compliant", [Page 127]

14.5.1 USA and Canada



The English translation is binding

Note that all statements made in this chapter on UL certification are binding only in the English version.

The German version of this chapter is purely informative.

A UL certificate is necessary for the operation of the AX8000 multi-axis servo system in the economic area of the USA or Canada. The devices have been certified according to the standards of the UL test laboratory and are permitted to bear the cULus logo on the name plate. The test number is: E195162.

The following specifications apply for UL-certified use:

- Components from the AX8000 multi-axis servo system may be used in an environment with non-conductive soiling. This corresponds to a pollution degree of 2. Note that occasionally, depending on the environmental conditions, temporary conductivity can be expected due to condensation.
- The wiring must use copper conductors with a thermal conductivity of at least 60 to 75 °C.
- The AX8000 multi-axis servo system does not offer an overheating sensor for the connected motor.
- You can operate motors of various sizes. You can adjust the level of the internal overload protection of the motor.

Canada



Approval in Canada without external transient suppression

As the UL and CSA have been harmonized into IEC/EN 61800-5-1, external transient protection is no longer required when using the AX8000 in Canada.

Index

A		O	
Accessories		Operating Conditions	41
Brake resistor	134	Ordering options	35
Braking resistor IP65	134	Drive-integrated safety technology	78
Mains chokes	134	Multi-feedback interface	36
B		P	
Brake resistor [+]		Pictograms	12
Documentation	134	Power derating	41
Braking resistor IP65 [+]		S	
Documentation	134	Safety	16
C		DC link capacitors	18
Cable lengths	67	De-energized and voltage-free state	18
Cleaning	133	Grounding	17
Commissioning	131	Hot surfaces	18
Connection		Intended use	38
Braking resistor	102	Keep the environment clean	17
Mechanics	82	Overheating	18
Modules	84	Protective equipment	17
Control voltage	69	Safety pictograms	17
D		Shut down and secure the machine or plant	17
DC link capacitance	65	Solvents and lubricants	18
Declaration of conformity	140	Tightening torques	17
Dimensional drawings	55	Safety pictograms	16
Display	70	Safety technology	
Disposal	137	STO; Safe Torque Off	78
Dual use	39	Scope of supply	59
E		Security	
Environmental conditions	41	General safety instructions	17
F		Servo drive	
Features	34	Commissioning	131
Fuses	125	Dimensioning	65
Fast discharge DC link	18	Disassembly	136
G		Disposal	136
General safety instructions	17	Electrical installation	87, 136
Grounding	95	Mechanical installation	82
I		Storage	61
Installation position	63	Transport	61
Instruction	11	Signal words	12
Intended use	38	Storage	61
L		Support	14
Label, see Safety pictograms	16	Symbols	12
M		T	
Mains choke [+]		Target group	10
Documentation	134	Technical data	41
Maintenance	133	Total motor cable length	67
Intervals	133	Transport	61
Motor feedback	111	U	
Multi-feedback	105	UL	141

15 Notes

Trademark statements

Beckhoff®, ATRO®, EtherCAT®, EtherCAT G®, EtherCAT G10®, EtherCAT P®, MX-System®, Safety over EtherCAT®, TC/BSD®, TwinCAT®, TwinCAT/BSD®, TwinSAFE®, XFC®, XPlanar® and XTS® are registered and licensed trademarks of Beckhoff Automation GmbH.

Third-party trademark statements

BiSS is a trademark of IC Haus GmbH.

EnDat is a trademark of Dr. Johannes Heidenhain GmbH.

More Information:
www.beckhoff.com/ax8000

Beckhoff Automation GmbH & Co. KG
Hülshorstweg 20
33415 Verl
Germany
Phone: +49 5246 9630
info@beckhoff.com
www.beckhoff.com

