

Manual | EN

# CX9020

Embedded PC

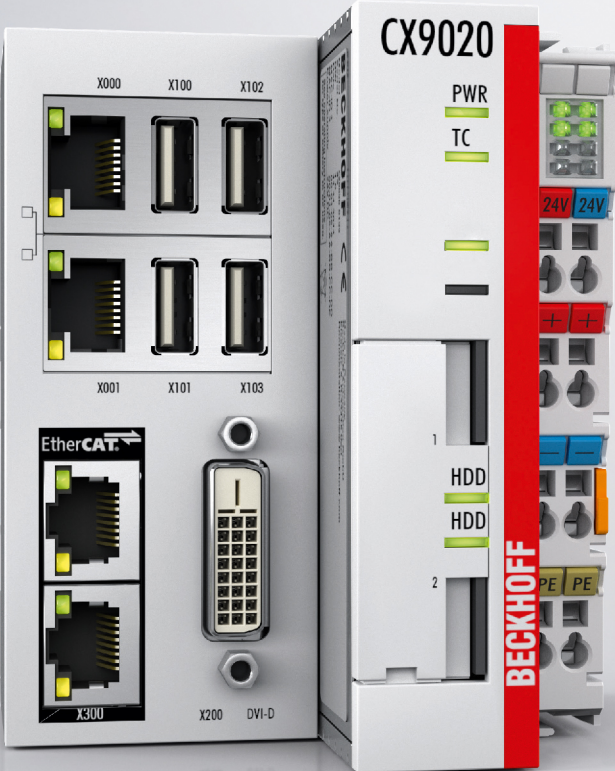



# Table of contents

<b>1</b>	<b>Notes on the documentation</b> .....	<b>5</b>
1.1	Representation and structure of warnings .....	5
1.2	Documentation issue status .....	7
<b>2</b>	<b>For your safety</b> .....	<b>8</b>
2.1	Intended use .....	8
2.2	Staff qualification .....	8
2.3	Safety instructions .....	9
2.4	Notes on information security .....	10
<b>3</b>	<b>Transport and storage</b> .....	<b>11</b>
<b>4</b>	<b>Product overview</b> .....	<b>12</b>
4.1	Structure of the CX9020 Embedded PC .....	13
4.2	Name plate .....	14
4.3	Types .....	14
4.4	Architecture overview .....	16
<b>5</b>	<b>Interface description</b> .....	<b>17</b>
5.1	USB (X100, X101, X102, X103).....	17
5.2	Ethernet RJ45 (X000, X001) .....	17
5.3	DVI-D (X200).....	19
5.4	Optional interfaces .....	19
5.4.1	Audio interface (N020) .....	20
5.4.2	RS232 (N030) .....	21
5.4.3	RS422/RS485 (N031) .....	22
5.4.4	EtherCAT slave (B110) .....	23
5.4.5	PROFIBUS (x310).....	24
5.4.6	CANopen (x510) .....	25
5.4.7	PROFINET RT (x930).....	26
<b>6</b>	<b>Commissioning</b> .....	<b>27</b>
6.1	Assembly.....	27
6.1.1	Note the permissible installation positions .....	27
6.1.2	Attaching on mounting rail.....	29
6.1.3	MicroSD card installation and removal.....	30
6.1.4	Installing passive EtherCAT Terminals .....	31
6.2	Connecting the power supply .....	32
6.3	Switching on .....	34
6.4	Switching off .....	34
<b>7</b>	<b>Configuration</b> .....	<b>35</b>
7.1	Windows Embedded Compact 7 .....	35
7.1.1	Setting up the audio interface (N020) .....	35
7.2	Beckhoff Device Manager .....	36
7.2.1	Starting the Beckhoff Device Manager.....	36
7.2.2	Enabling a remote display.....	37
7.2.3	Starting a remote connection .....	38
7.3	TwinCAT.....	39

7.3.1	Tree view.....	39
7.3.2	Searching for target systems .....	40
7.3.3	Scanning an Embedded PC.....	42
<b>8</b>	<b>NOVRAM .....</b>	<b>43</b>
8.1	Use under TwinCAT 3.....	44
8.1.1	Creating a Retain Handler.....	44
8.1.2	Creating and linking variables .....	46
8.1.3	Writing speed of the Retain Handler .....	48
8.1.4	Deleting variables under the Retain Handler .....	49
<b>9</b>	<b>1-second UPS (persistent variables).....</b>	<b>50</b>
9.1	FB_S_UPS_CX9020_U900 .....	52
9.2	Data types .....	54
9.3	Checking the validity of the variables.....	54
9.3.1	SYSTEMINFOTYPE .....	54
9.3.2	PlcAppSystemInfo.....	56
<b>10</b>	<b>Error handling and diagnostics .....</b>	<b>58</b>
10.1	Diagnostic LEDs.....	58
10.1.1	K-bus.....	58
10.1.2	E-bus.....	61
10.2	Faults .....	62
<b>11</b>	<b>Care and maintenance .....</b>	<b>63</b>
11.1	Replace the battery .....	64
11.2	Cleaning the Embedded PC.....	64
<b>12</b>	<b>Decommissioning .....</b>	<b>66</b>
12.1	Removing cables.....	66
12.2	Dismantling the Embedded PC .....	66
<b>13</b>	<b>Technical data .....</b>	<b>68</b>
<b>14</b>	<b>Appendix.....</b>	<b>71</b>
14.1	Accessories .....	71
14.2	Certifications .....	71
14.3	Support and Service.....	72
	<b>List of tables .....</b>	<b>73</b>
	<b>List of figures.....</b>	<b>74</b>

# 1 Notes on the documentation

This description is intended exclusively for trained specialists in control and automation technology who are familiar with the applicable national standards.

The documentation and the following notes and explanations must be complied with when installing and commissioning the components.

The trained specialists must always use the current valid documentation.

The trained specialists must ensure that the application and use of the products described is in line with all safety requirements, including all relevant laws, regulations, guidelines, and standards.

## Disclaimer

The documentation has been compiled with care. The products described are, however, constantly under development.

We reserve the right to revise and change the documentation at any time and without notice.

Claims to modify products that have already been supplied may not be made on the basis of the data, diagrams, and descriptions in this documentation.

## Trademarks

Beckhoff®, ATRO®, EtherCAT®, EtherCAT G®, EtherCAT G10®, EtherCAT P®, MX-System®, Safety over EtherCAT®, TC/BSD®, TwinCAT®, TwinCAT/BSD®, TwinSAFE®, XFC®, XPlanar®, and XTS® are registered and licensed trademarks of Beckhoff Automation GmbH.

If third parties make use of the designations or trademarks contained in this publication for their own purposes, this could infringe upon the rights of the owners of the said designations.



EtherCAT® is a registered trademark and patented technology, licensed by Beckhoff Automation GmbH, Germany.

## Copyright

© Beckhoff Automation GmbH & Co. KG, Germany.

The distribution and reproduction of this document, as well as the use and communication of its contents without express authorization, are prohibited.

Offenders will be held liable for the payment of damages. All rights reserved in the event that a patent, utility model, or design are registered.

## Third-party trademarks

Trademarks of third parties may be used in this documentation. You can find the trademark notices here: <https://www.beckhoff.com/trademarks>.

## 1.1 Representation and structure of warnings

The following warnings are used in the documentation. Read and follow the warnings.

### Warnings relating to personal injury:

#### DANGER

Hazard with high risk of death or serious injury.

#### WARNING

Hazard with medium risk of death or serious injury.

#### CAUTION

There is a low-risk hazard that can result in minor injury.

**Warnings relating to damage to property or the environment:**

**NOTICE**

There is a potential hazard to the environment and equipment.

**Notes showing further information or tips:**



This notice provides important information that will be of assistance in dealing with the product or software. There is no immediate danger to product, people or environment.

## 1.2 Documentation issue status

Version	Changes
0.1	Provisional version (original version)
1.0	First release
1.1	SUPS notes added
1.2	SUPS notes changed
1.3	Figures in chapter Battery compartment revised
1.4	Chapter Technical data revised
1.5	Architecture overview added, chapter Types revised
1.6	Chapter LAN connections revised
1.7	Chapter NOVRAM added, Chapter 1-second UPS revised
1.8	Documentation restructured and revised
1.9	Notes on operation in hazardous areas added.
2.0	Chapter Beckhoff Device Manager revised
2.1	Chapter "RS232 (N030)" adapted.
2.2	Chapter "Power supply" adapted.
2.3	Chapter "Technical data" adapted.
2.4	Chapters "Product Overview" and "Device Manager" adapted.
2.5	Chapters "Safety instructions", "Interface description", "1-second UPS", "Error handling and diagnostics" and "Appendix" revised.
2.6	Chapters "Care and maintenance" and "Accessories" adapted.

## 2 For your safety

Read the chapter on safety and follow the instructions in order to protect from personal injury and damage to equipment.

### Limitation of liability

All the components are supplied in particular hardware and software configurations appropriate for the application. Unauthorized modifications and changes to the hardware or software configuration, which go beyond the documented options, are prohibited and nullify the liability of Beckhoff Automation GmbH & Co. KG.

In addition, the following actions are excluded from the liability of Beckhoff Automation GmbH & Co. KG:

- Failure to comply with this documentation.
- Improper use.
- Use of untrained personnel.
- Use of unauthorized replacement parts.

## 2.1 Intended use

The Embedded PC is designed for a working environment that meets the requirements of protection class IP20. This involves finger protection and protection against solid foreign objects up to 12.5 mm, but not protection against water. Operation of the devices in wet and dusty environments is not permitted, unless specified otherwise. The specified limits for electrical and technical data must be adhered to.

### In hazardous areas

Device modification CX2900-0107 is mandatory for operation of the embedded PC in hazardous areas, zone 2/22. The device modification includes a factory-installed retainer bracket for mechanically securing the connectors.

The device modification is mandatory for operating the embedded PC in the following hazardous areas:

1. For zone 2 atmospheres in which gas is present as a combustible material. Zone 2 means that an explosive atmosphere does usually not occur during normal operation, or only for a short time.
2. For zone 22 atmospheres in which dust is present as a combustible material. Zone 22 means that an explosive atmosphere in the form of a cloud does usually not occur during normal operation, or only for a short time.

The embedded PC must be installed in a housing, which ensures protection rating IP54 for gas according to EN 60079-15. A housing with protection rating IP54 is required for non-conductive dust. IP6X is required for conductive dust according to EN 60079-31.

### Improper use

The embedded PC is not suitable for operation in the following areas:

- In hazardous areas, the embedded PC may not be used in other zones except for 2/22 and not without a suitable housing.
- Areas with an aggressive environment, e.g. aggressive gases or chemicals.
- Living areas. In living areas, the relevant standards and guidelines for interference emissions must be adhered to, and the devices must be installed in housings or control boxes with suitable attenuation of shielding.

## 2.2 Staff qualification

All operations involving Beckhoff software and hardware may only be carried out by qualified personnel with knowledge of control and automation engineering. The qualified personnel must have knowledge of the administration of the Industrial PC and the associated network.

All interventions must be carried out with knowledge of control programming, and the qualified personnel must be familiar with the current standards and guidelines for the automation environment.

## 2.3 Safety instructions

The following safety instructions must be followed during installation and working with networks and the software.

### Explosion protection

Device modification CX2900-0107 is mandatory for operation of the embedded PC in hazardous areas, zone 2/22. The device modification entails the modification and relocation of the device label and a factory-fitted retainer bracket for mechanically securing the connectors.

#### WARNING

##### Operation without device modification

Without the CX2900-0107 device modification, the USB plugs may slip out of the USB interfaces due to vibration, which may trigger a deflagration or explosion.

The embedded PC must only be used with the device modification, and the USB plugs must be secured to the retainer brackets with cable ties.

Tighten the screws of the DVI plugs and, if present, also the screws of the fieldbus plugs, in order to prevent the plugs slipping out. Only use RJ45 plugs with an intact latching lug. Use cable ties to secure the USB and RJ45 plugs to the retainer brackets.

The CXxxxx-N020 optional interface (audio interface) may not be used in hazardous areas.

The embedded PC must be installed in a housing, which ensures protection rating IP54 for gas according to EN 60079-15. A housing with protection rating IP54 is required for non-conductive dust. IP6X is required for conductive dust according to EN 60079-31.

Observe the temperature at the cable entry points into the housing. If the temperature during nominal operation is higher than 70 °C at the entry points or higher than 80 °C at the wire branching points, cables must be selected that are designed for these high temperatures and operation in hazardous areas.

Maintain the prescribed ambient temperature during operation. The permissible ambient temperature range during operation is -25 °C ... +60 °C.

Take measures to prevent the rated operating voltage exceeding 119 V through short-term interference voltages.

Switch off the power supply and ensure that no explosive atmosphere occurs when:

- bus terminals are connected or removed,
- the embedded PC is wired or cables are connected,
- the front flap is opened,
- the CFast card, MicroSD card or battery is replaced.

### Mounting

- Never work on live equipment. Always switch off the power supply for the device before installation, troubleshooting or maintenance. Protect the device against unintentional switching on.
- Observe the relevant accident prevention regulations for your machine (e.g. the BGV A 3, electrical systems and equipment).
- Ensure standard-compliant connection and avoid risks to personnel. Ensure that data and supply cables are laid in a standard-compliant manner and ensure correct connection.
- Observe the relevant EMC guidelines for your application.
- Avoid polarity reversal of the data and supply cables, as this may cause damage to the equipment.

- The devices contain electronic components, which may be destroyed by electrostatic discharge when touched. Observe the safety precautions against electrostatic discharge according to DIN EN 61340-5-1/-3.

### Working with networks

- Restrict access to all devices to an authorized circle of persons.
- Change the default passwords to reduce the risk of unauthorized access.
- Protect the devices with a firewall.
- Apply the IT security precautions according to IEC 62443, in order to limit access to and control of devices and networks.

### Working with the software

- The sensitivity of a PC against malicious software increases with the number of installed and active software.
- Uninstall or disable unnecessary software.

Further information on the safe handling of networks and software can be found in the Beckhoff Information System:

<http://infosys.beckhoff.com>

Document name
IPC Security Guideline

## 2.4 Notes on information security

The products of Beckhoff Automation GmbH & Co. KG (Beckhoff), insofar as they can be accessed online, are equipped with security functions that support the secure operation of plants, systems, machines and networks. Despite the security functions, the creation, implementation and constant updating of a holistic security concept for the operation are necessary to protect the respective plant, system, machine and networks against cyber threats. The products sold by Beckhoff are only part of the overall security concept. The customer is responsible for preventing unauthorized access by third parties to its equipment, systems, machines and networks. The latter should be connected to the corporate network or the Internet only if appropriate protective measures have been set up.

In addition, the recommendations from Beckhoff regarding appropriate protective measures should be observed. Further information regarding information security and industrial security can be found in our <https://www.beckhoff.com/secguide>.

Beckhoff products and solutions undergo continuous further development. This also applies to security functions. In light of this continuous further development, Beckhoff expressly recommends that the products are kept up to date at all times and that updates are installed for the products once they have been made available. Using outdated or unsupported product versions can increase the risk of cyber threats.

To stay informed about information security for Beckhoff products, subscribe to the RSS feed at <https://www.beckhoff.com/secinfo>.

## 3 Transport and storage

### Transport

#### NOTICE

##### Short circuit due to moisture

Moisture can form during transport in cold weather or in the event of large temperature fluctuations.

Avoid moisture formation (condensation) in the embedded PC, and leave it to adjust to room temperature slowly. If condensation has occurred, wait at least 12 hours before switching on the embedded PC.

Despite the robust design of the unit, the components are sensitive to strong vibrations and impacts. Transporting a control cabinet with a built-in embedded PC can result in excessive impact on the embedded PC.

- During transport, the device must therefore be protected from excessive mechanical stress.
- Appropriate packaging of the industrial PC, in particular the original packaging, can improve vibration resistance during transport.
- Send the embedded PC in the original packaging and additional outer packaging.

Table 1: Dimensions and weight.

	CX9020
Dimensions (W x H x D)	84 mm x 100 mm x 91 mm
Weight	approx. 590 g

### Storage

- Remove the battery from the Embedded PC if storage temperatures exceed 60 °C. The battery should be stored separate from the Embedded PC in a dry environment at a temperature between 0 °C and 30 °C.  
The preset date and time are lost if the battery is removed.

## 4 Product overview

The CX9020 Embedded PC is a full-fledged PC with the following basic configuration:

- two MicroSD card slots,
- two switched Ethernet interfaces,
- four USB 2.0 interfaces,
- and a DVI-D interface

The operating system is Microsoft Windows Embedded Compact 7.

The Embedded PC features internal persistent data memory in the form of 128 kB NOVRAM. In the event of a power failure, important data are stored in the NOVRAM and are available again after a restart.

The CX9020 Embedded PC can be ordered ex factory with a 1-second UPS (CX9020-U900). The 1-second UPS enables up to 1 MB of persistent data to be saved to the MicroSD card in the event of a loss of power.

The basic CPU module can be ordered ex factory with an optional interface. The optional interface cannot be retrofitted.

*Table 2: Available optional interfaces for the CX9020.*

CX9020-xxxx	Optional interfaces
CX9020-N020	Audio interface, 3 x 3.5 mm jack plug, Line-In, Mic-In, Line-Out
CX9020-N030	RS232, D-sub connector, 9-pin.
CX9020-N031	RS422/RS485, D-sub socket, 9-pin.
CX9020-B110	EtherCAT slave, EtherCAT IN and OUT (2 x RJ45).
CX9020-M310	PROFIBUS master, D-sub socket, 9-pin.
CX9020-B310	PROFIBUS slave, D-sub socket, 9-pin.
CX9020-M510	CANopen master, D-sub connector, 9-pin.
CX9020-B510	CANopen slave, D-sub connector, 9-pin.
CX9020-M930	PROFINET RT, controller, Ethernet (2 x RJ-45).
CX9020-B930	PROFINET RT, device, Ethernet (2 x RJ-45 switch).
CX9020-B950	EtherNet/IP Slave interface, Ethernet (2 RJ45 switches)

### Power supply terminal

The power supply terminal for the Embedded PC is located on the right-hand side. Bus Terminals (K-bus) or EtherCAT Terminals (E-bus) can be attached on the right-hand side of the power supply terminal. The power supply terminal automatically recognizes the respective bus system (K-bus or E-bus).

### Software

In combination with the TwinCAT automation software the CX9020 Embedded PC becomes a powerful IEC 61131-3 PLC. All IEC 61131-3 languages can be used.

Functions for Motion Control are also available, such as simple point-to-point movements.

In addition to real-time execution of control tasks, the TwinCAT real-time kernel ensures that enough time remains for the user interface (HMI), to communicate with the real-time components via software interfaces such as ADS or OPC.

## 4.1 Structure of the CX9020 Embedded PC

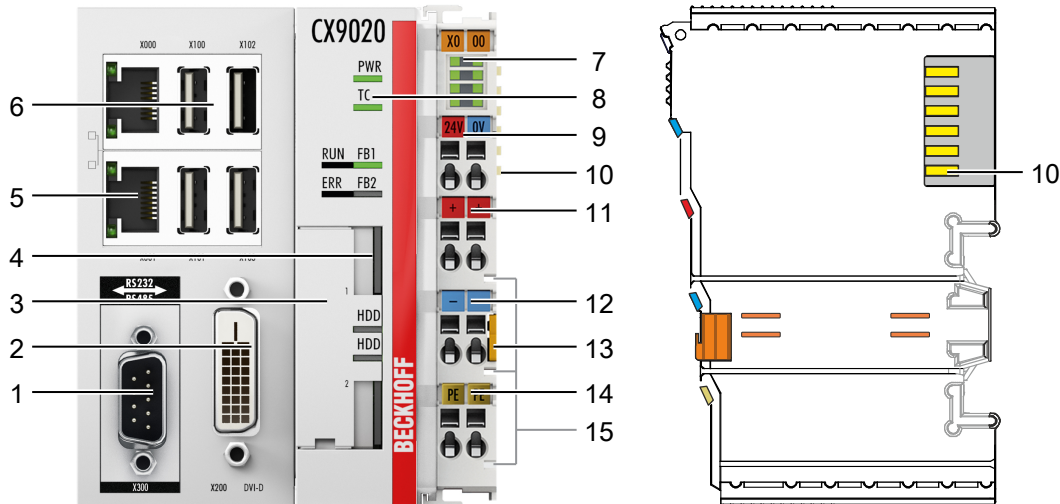

Fig. 1: Structure of the CX9020 Embedded PC.

Table 3: Legend for the configuration.

No.	Component	Description
1	Optional interface (X300).	Space for interfaces such as RS232, EtherCAT, CANopen or others. The optional interface must be ordered ex factory and cannot be retrofitted retrospectively.
2	DVI-D interface (X200).	Interface for a monitor or Panel.
3	Battery compartment (under the front flap).	Power supply for the battery-backed clock for time and date.
4	2x MicroSD card slots. <a href="#">[▶ 30]</a>	Slot for industrial MicroSD cards.
5	RJ45 Ethernet interfaces <a href="#">[▶ 17]</a> (X000, X001).	Switched Ethernet interfaces. For connecting to local networks or the internet.
6	USB interfaces (X100, X101, X102, X103).	Interfaces for peripherals such as mouse, keyboard or USB memory.
7	Diagnostic LEDs, power supply terminal. <a href="#">[▶ 58]</a>	Diagnosis of the power supply for the Embedded PC and the Terminal Bus. Status of the E-bus and K-bus communication.
8	Diagnostic LEDs.	Diagnostic LEDs for power supply, TwinCAT and the optional interface.
9	Spring-loaded terminals, +24 V and 0 V	Power supply for Embedded PC.
10	Terminal bus (K- or E-bus)	Interface for EtherCAT Terminals or Bus Terminals. Data exchange and supply.
11	Spring-loaded terminal, +24 V	Power supply for Bus Terminals via power contact.
12	Spring-loaded terminal, 0 V	Power supply for Bus Terminals via power contact.
13	Terminal release	Releases the power supply terminal and therefore the Embedded PC from the mounting rail.
14	Spring-loaded terminal, PE	Spring-loaded terminal for power contact PE.
15	Power contacts, +24 V, 0 V, PE	Power contacts for Bus Terminals.

## 4.2 Name plate

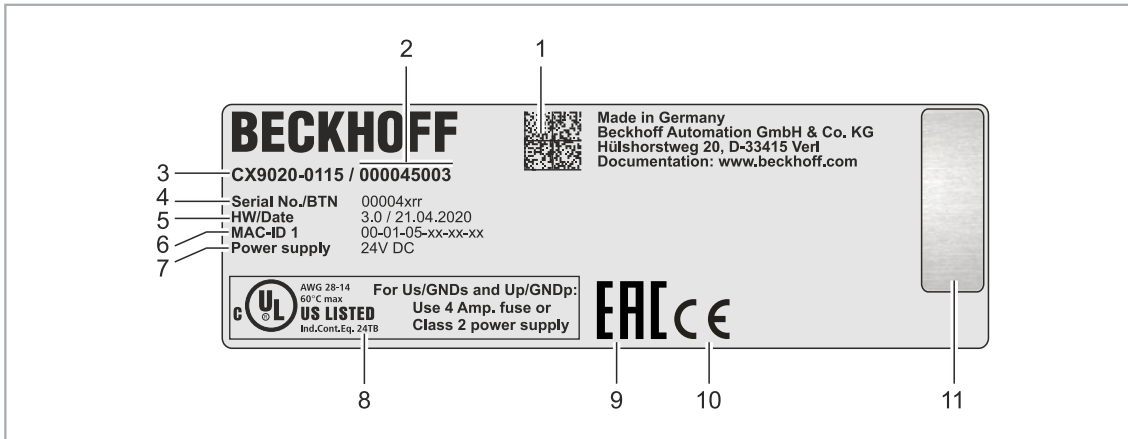

Fig. 2: Name plate example.

Table 4: Information on the name plate.

No.	Description
1	Machine-readable information in the form of a Data Matrix Code (DMC, code scheme ECC200) that you can use for better identification and management.
2	Variant number for identification of the Embedded PC configuration. With this number, the exact configuration of Embedded PC, operating system, options and TwinCAT can be reordered.
3	Product designation for identification of the Embedded PC.
4	Serial number/ Beckhoff Traceability Number (BTN) for the unambiguous identification of the product.
5	Hardware version and date of manufacture.
6	MAC addresses of the built-in Ethernet interfaces. The host name is made up of CX and the last three bytes of the MAC address. Example: the MAC address: 00-01-05-aa-bb-cc results in the host name <b>CX-aabbcc</b> .
7	Power supply 24 V DC
8	UL marking with prescribed information on power supply, fuse, temperature and cable cross-sections.
9	EAC marking
10	CE marking
11	License sticker for operating system (optional).

## 4.3 Types

The CX9020 Embedded PC can be ordered with different software options. Use this overview in conjunction with the information on the name plate to ascertain the operating system and the TwinCAT version of the embedded PC.

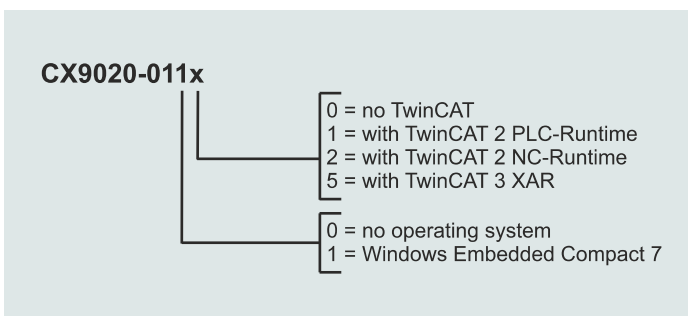

Fig. 3: Nomenclature for the CX9020 Embedded PC.

The CX9020 Embedded PC is available with the following software options:

*Table 5: CX9020 (1 GHz 1 core), ordering information for software.*

Module	no operating system	Windows Embedded Compact 7	no TwinCAT	TwinCAT 2 PLC-Runtime	TwinCAT 2 NC-Runtime	TwinCAT 3 XAR
CX9020-0100	X		X			
CX9020-0110		X	X	-	-	-
CX9020-0111		X	-	X	-	-
CX9020-0112		X	-	-	X	-
CX9020-0115		X	-	-	-	X

The support period for the Microsoft Windows Embedded Compact 7 operating system has already expired. Security updates can therefore no longer be provided. TwinCAT is only supported up to and including Build 4024.

## 4.4 Architecture overview

The architecture of the CX9020 Embedded PC is described below.

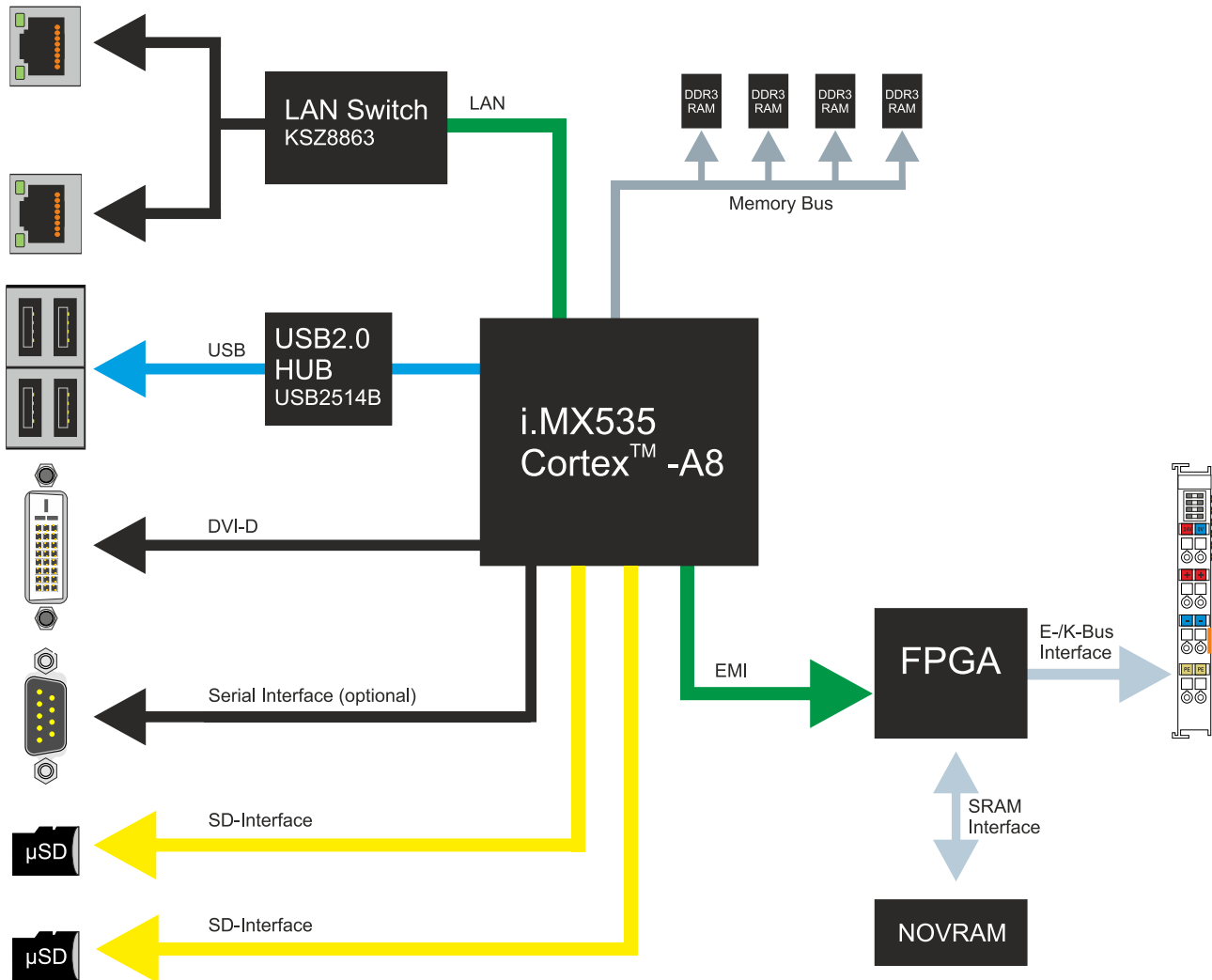

The CX9020 Embedded PC is based on the ARMv7-A microarchitecture developed by Arm®. The following CPU is used in the CX9020:

- i.MX535 Cortex®-A8

Details for the CPU can be read at Arm®. The memory is connected directly to the CPU. The embedded PC is available in one memory configuration: with 1 GB DDR3 RAM. The memory is not extendable. The CX9020 Embedded PC has two microSD card slots.

The CPU provides all required interfaces:

- 2x switched Ethernet RJ45 ports
- 4x USB 2.0
- DVI-D
- serial interface (CX9020-N03x)
- 1 EMI to FPGA for K-bus/E-bus and NOVRAM
- 2x microSD card slots

The USB, DVI, and LAN interfaces are standard interfaces. They can be used for operating devices that comply with the relevant standard. Only digital signals can be transmitted via the DVI-D interface.

The RJ45 interfaces are fed to an internal switch and no additional Ethernet switches are required.

## 5 Interface description

### 5.1 USB (X100, X101, X102, X103)

The Embedded PC has four independent USB interfaces for connecting keyboards, mice, touchscreens and other input or data storage devices.

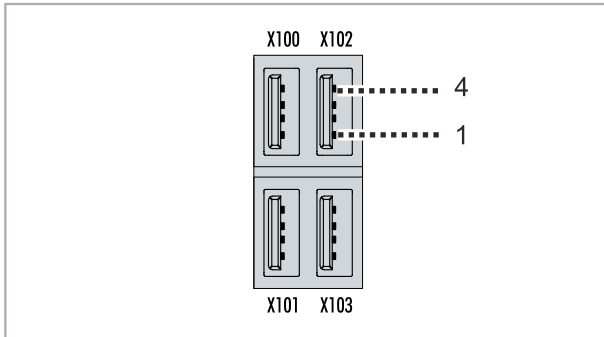

Fig. 4: USB interfaces (X100, X101, X102, X103).

The USB interfaces are type A and comply with the USB 2.0 specification.

Table 6: USB interfaces (X100, X101, X102, X103), pin assignment.

Pin	Connection	Typical assignment
1	VBUS	Red
2	D-	White
3	D+	Green
4	GND	Black
Shell	Shield	Drain Wire

Note the power consumption of the individual devices. Each interface is limited to 500 mA.

### 5.2 Ethernet RJ45 (X000, X001)

Both Ethernet interfaces are switched and dependent on each other. Please note the following points for an embedded PC with switched Ethernet interfaces:

- The interface is not supported for EtherCAT. Do not use the interface in combination with EtherCAT. The EtherCAT telegrams (broadcast) disturb the local network, the consequence being that the embedded PC can no longer be reached via a host PC. You can still use the interface for EAP (EtherCAT Automation Protocol), for example.
- No additional switch is required for a line topology.

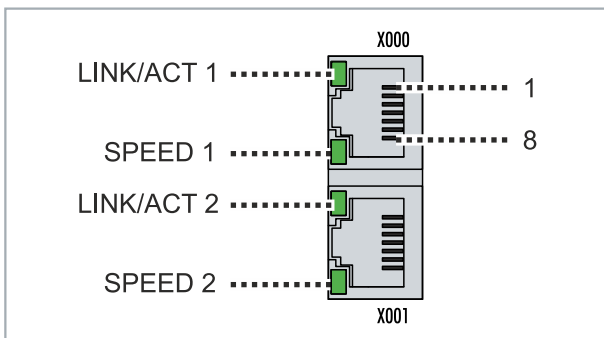

Fig. 5: Ethernet interfaces X000, X001.

Both Ethernet interfaces reach speeds of 10 / 100 Mbit. The LEDs on the left of the interfaces indicate the connection status. The upper LED (LINK/ACT) indicates whether the interface is connected to a network. If this is the case the LED is yellow. The LED flashes when data transfer is underway on the interface.

The lower LED (SPEED) indicates the connection speed. The LED is not lit if the speed is 10 Mbit. At 100 Mbit the LED is green.

*Table 7: Ethernet interface X000 and X001, pin assignment.*

<b>PIN</b>	<b>Signal</b>	<b>Description</b>
1	TD +	Transmit +
2	TD -	Transmit -
3	RD +	Receive +
4	connected	not used
5		
6	RD -	Receive -
7	connected	not used
8		

### 5.3 DVI-D (X200)

The DVI-D interface (X200) transfers digital data and is suitable for connection to digital displays. The resolution on the display or the Beckhoff Control Panel depends on the distance from the display device. The maximum distance is 5 m. Beckhoff offers various panels with an integrated DVI extension. A cable length of up to 50 meters is therefore possible.

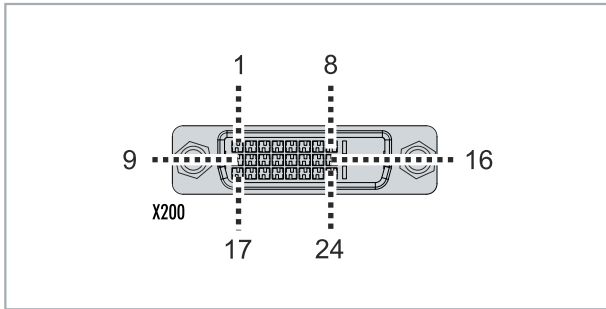

Fig. 6: DVI-D interface X200.

Table 8: DVI-D interface X200, pin assignment.

Pin	Connection	Pin	Connection	Pin	Connection
1	TMDS Data 2-	9	TMDS Data 1-	17	TMDS Data 0-
2	TMDS Data 2+	10	TMDS Data 1+	18	TMDS Data 0+
3	TMDS Data 2/4 Shield	11	TMDS Data 1/3 Shield	19	TMDS Data 0/5 Shield
4	not connected	12	not connected	20	not connected
5	not connected	13	not connected	21	not connected
6	DDC Clock	14	+ 5V Power	22	TMDS Clock Shield
7	DDC Data	15	Ground ( +5V, Analog H/ V Sync)	23	TMDS Clock +
8	Analog Vertical Sync	16	Hot Plug Detect	24	TMDS Clock -

Table 9: DVI-D interface X200, resolution at the monitor.

Resolution in pixels	Distance of the interface from the monitor
1920 x 1200	5 m
1920 x 1080	5 m
1600 x 1200	5 m
1280 x 1024	5 m
1024 x 768	5 m
800 x 600	5 m
640 x 480	5 m

The embedded PC also supports higher resolutions, based on the DVI standard. A maximum resolution of 1920 x 1200 pixels can be set on the embedded PC. Whether this resolution is achieved depends on the monitor, the cable quality, and the cable length.

### 5.4 Optional interfaces

An optional interface is an additional interface that can be equipped with a wide range of signal types ex factory and extends the Embedded PC beyond the basic equipment. The optional interface must be ordered in advance and cannot be retrofitted to the device.

### 5.4.1 Audio interface (N020)

Two inputs are available: "LINE IN" (X300) and "MIC IN" (X301). The "LINE OUT" interface (X302) is intended for audio signal output. The 3.5 mm sockets are designed for jack plugs. It can also be used for connecting headphones with a maximum output of 200 mW.

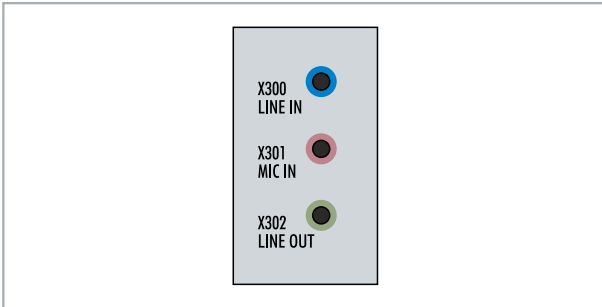

Fig. 7: Audio interface X300, X301, X302.

The audio interfaces are accessed via the operating system. The audio interface operates in stereo mode as standard, using stereo outputs/inputs and a single-channel input for the microphone. The inputs should be connected as indicated.

The left channel is transferred via the tip of the jack plug, the right channel via the first ring. The remainder of the sleeve is used for earthing.

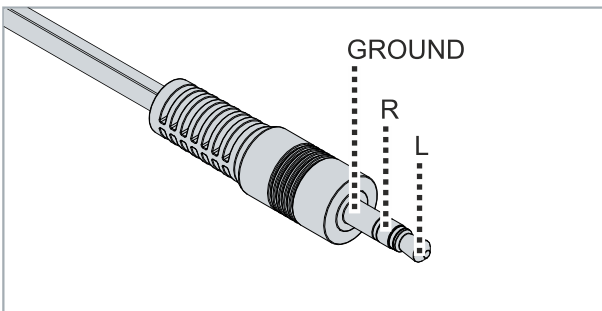

Fig. 8: Line In / Line Out X300, X302 jack plugs.

Table 10: Line In /Line Out jack plugs, pin assignment.

Signal	Description
L	Left channel
R	Right channel
Ground	Ground

The only existing channel is transferred via the tip, the remainder of the sleeve is used for earthing.

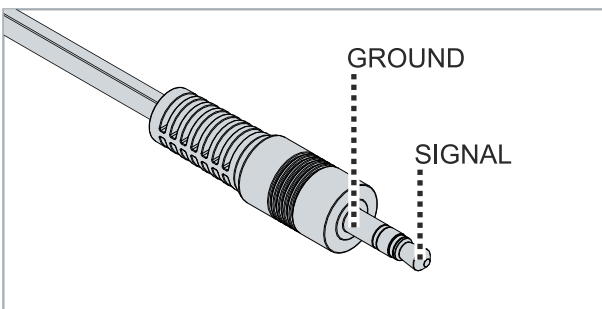

Fig. 9: Mic In X301 jack plug.

### 5.4.2 RS232 (N030)

The optional N030 interface provides an RS232 interface (X300). The RS232 interface is implemented on a 9-pin D-sub connector.

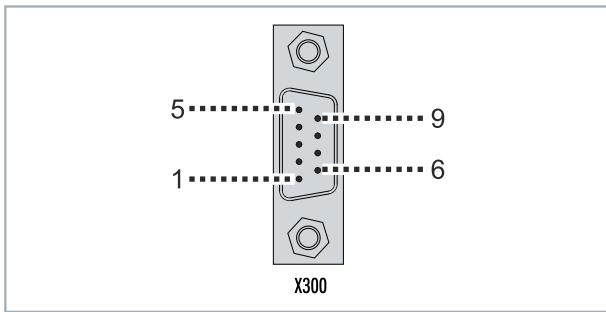

Fig. 10: RS232 interface X300.

The maximum baud rate on both channels is 115 kbit. The interface parameters are set via the operating system or from the PLC program.

Table 11: RS232 interface X300, pin assignment.

PIN	Signal	Type	Description
1	-	-	-
2	RxD	Signal in	Receive Data
3	TxD	Signal out	Transmit Data
4	-	-	-
5	GND	Ground	Ground
6	-	-	-
7	RTS	Signal out	Request to Send
8	CTS	Signal in	Clear to Send
9	-	-	-

### 5.4.3 RS422/RS485 (N031)

The optional N031 interface provides an RS422 or RS485 interface (X300). The interface is executed on a 9-pin D-sub socket.

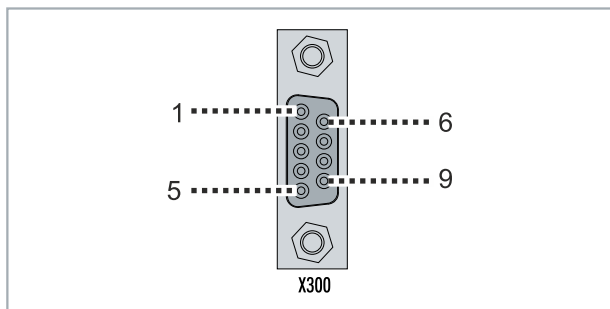

Fig. 11: RS485 interface X300.

The maximum baud rate on both channels is 115 kbit. The interface parameters are set via the operating system or from the PLC program.

Table 12: RS422/485 interface, pin assignment.

PIN	Signal	Type	Description
2	TxD+	Data-Out +	Transmit 422
3	RxD+	Data-In +	Receive 422
5	GND	Ground	Ground
6	VCC	VCC	+5 V
7	TxD-	Data-Out -	Transmit 422
8	RxD-	Data-In -	Receive 422

For RS 485 pins 2 and 3 (data +) must be connected, and pins 7 and 8 (data -).

By default the interface is parameterized as follows on delivery:

Table 13: Default setting, RS485 without echo with end point (terminated).

Function	Status
Echo on	off
Echo off	on
Auto send on	on
Always send on	off
Auto receive on	on
Always receive on	off
Term on	on
Term on	On

#### Other configurations for the RS485 interface

Other configurations for the RS485 interface can be ordered ex factory. The following options are available:

- N031-0001 RS485 with echo, end point (terminated).
- N031-0002 RS485 without echo, stub (without termination).
- N031-0003 RS485 with echo, stub (without termination).
- N031-0004 RS422 full duplex end point (terminated).

An RS485 interface cannot be configured retrospectively and must always be ordered ex factory as required.

### 5.4.4 EtherCAT slave (B110)

The latest generation of embedded PCs can be ordered ex factory with an EtherCAT slave interface (B110). On the devices, the optional B110 interface is referred to as X300.

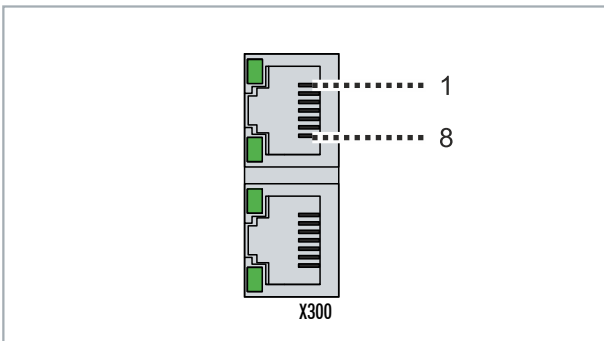

Fig. 12: EtherCAT slave interface X300.

The incoming EtherCAT signal is connected to the upper LAN interface. The lower LAN interface relays the signal to other EtherCAT slave devices.

Table 14: EtherCAT slave interface X300, pin assignment.

PIN	Signal	Description
1	TD +	Transmit +
2	TD -	Transmit -
3	RD +	Receive +
4	connected	reserved
5		
6	RD -	Receive -
7	connected	reserved
8		

For the EtherCAT slave optional interface (B110), documentation with further information is available: [https://infosys.beckhoff.com/content/1033/b110\\_ethercat\\_optioninterface/index.html?id=2623834056269338700](https://infosys.beckhoff.com/content/1033/b110_ethercat_optioninterface/index.html?id=2623834056269338700)

Document name
CXxxxx-B110   EtherCAT Slave Optional Interface.

### 5.4.5 PROFIBUS (x310)

Pin 6 transfers  $5 V_{DC}$ , pin 5 transfers GND for the active termination resistor. These must never be used for other functions, as this can lead to destruction of the device.

Pins 3 and 8 transfer the PROFIBUS signals. These must never be swapped over, as this will prevent communication.

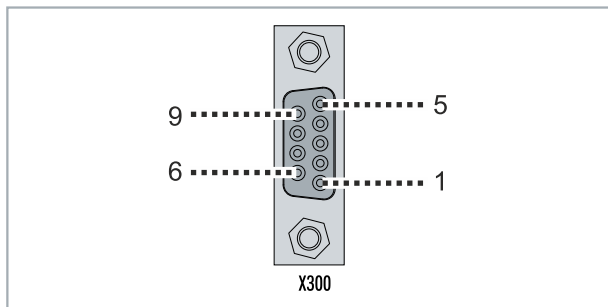

Fig. 13: PROFIBUS interface X310.

The Profibus bus line is connected via a 9-pin D-sub with the following pin assignment:

Table 15: PROFIBUS interface X310, pin assignment.

Pin	Connection
1	Shielding
2	not used
3	RxD/TxD-P
4	not used
5	GND
6	+5 $V_{DC}$
7	not used
8	RxD/TxD-N
9	not used

Table 16: Wire colors of the PROFIBUS line.

PROFIBUS line	D-sub
B red	Pin 3
A green	Pin 8

For the PROFIBUS optional interface (x310), documentation with further information is available:

[https://infosys.beckhoff.com/content/1033/m310\\_b310\\_profibus\\_optioninterface/index.html?id=2233561431434830097](https://infosys.beckhoff.com/content/1033/m310_b310_profibus_optioninterface/index.html?id=2233561431434830097)

Document name
CXxxx-M310/B310   Profibus Optional Interface

### 5.4.6 CANopen (x510)

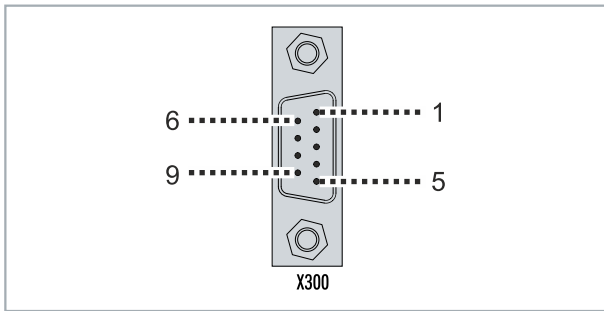

Fig. 14: CANopen interface X510.

The CAN bus line is connected via a 9-pin D-sub connector with the following pin assignment:

Table 17: CANopen interface X510, pin assignment.

Pin	Connection
1	not used
2	CAN low (CAN-)
3	CAN Ground (internally connected to pin 6)
4	not used
5	Shield
6	CAN Ground (internally connected to pin 3)
7	CAN high (CAN+)
8	not used
9	not used

For the CANopen optional interface (x510), documentation with further information is available:  
[https://infosys.beckhoff.com/content/1033/m510\\_b510\\_canopen\\_optioninterface/index.html?id=1404127979601372947](https://infosys.beckhoff.com/content/1033/m510_b510_canopen_optioninterface/index.html?id=1404127979601372947)

Document name
CXxxxx-M510/B510   CANopen Optional Interface

### 5.4.7 PROFINET RT (x930)

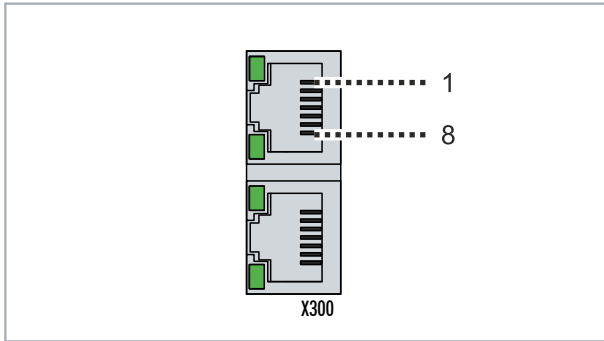

Fig. 15: PROFINET RT interface X300.

Table 18: PROFINET RT interface, pin assignment.

PIN	Signal	Description
1	TD +	Transmit +
2	TD -	Transmit -
3	RD +	Receive +
4	connected	reserved
5		
6	RD -	Receive -
7	connected	reserved
8		

For the PROFINET RT optional interface (x930), documentation with further information is available:  
[https://infosys.beckhoff.com/content/1033/m930\\_b930\\_profinet\\_optioninterface/index.html?id=3617310193267164961](https://infosys.beckhoff.com/content/1033/m930_b930_profinet_optioninterface/index.html?id=3617310193267164961)

Document name
CXxxxx-M930/B930   Profinet Optional Interface

## 6 Commissioning

### 6.1 Assembly

#### 6.1.1 Note the permissible installation positions

**i** **Increased heat generation**

The Embedded PC may overheat if the installation position is incorrect or the minimum distances are not adhered to.

The Embedded PC may only be operated at ambient temperatures of up to 60 °C. Ensure adequate ventilation. Select a horizontal installation position. Leave at least 30 mm clearance above and below the Embedded PC.

Install the Embedded PC horizontally in the control cabinet on a mounting rail, in order to ensure optimum heat dissipation.

Note the following specifications for the control cabinet:

- The Embedded PC should only be operated at ambient temperatures between -25 °C and 60 °C. Measure the temperature below the Embedded PC at a distance of 30 mm to the cooling fins, in order to determine the ambient temperature correctly.
- Adhere to the minimum distances of 30 mm above and below the Embedded PCs.
- Additional electrical equipment affects the heat generation in the control cabinet. Select a suitable control cabinet enclosure depending on the application, or ensure that excess heat is dissipated from the control cabinet.

#### Correct installation position

The Embedded PC must be installed horizontally on the mounting rail. Ventilation openings are located at the top and bottom of the housing. This ensures an optimum airflow through the Embedded PC in vertical direction. In addition, a minimum clearance of 30 mm above and below the Embedded PCs required, in order to ensure adequate ventilation.

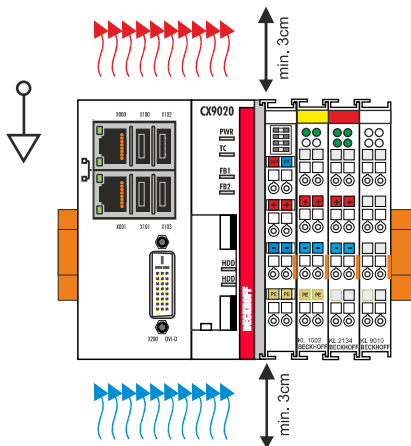

Fig. 16: CX9020 Embedded PC, permissible installation position.

If vibrations and impact occurs in the same direction as the mounting rail, the Embedded PC must be secured with an additional bracket, in order to prevent it slipping.

**Incorrect installation positions**

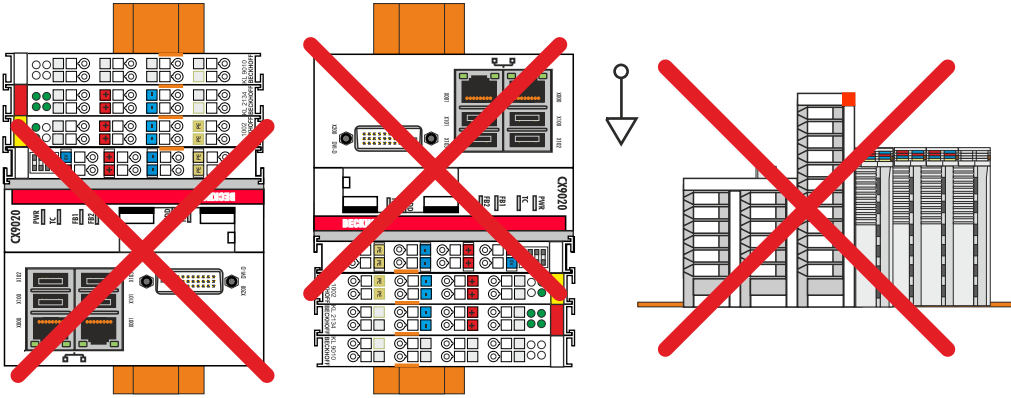

Fig. 17: CX9020 Embedded PC, invalid installation positions.

## 6.1.2 Attaching on mounting rail

The housing is designed such that the Embedded PC can be pushed against the mounting rail and latched onto it.

Requirements:

- Mounting rail of type TS35/7.5 or TS35/15 according to DIN EN 60715.

**Secure the Embedded PC on the mounting rail as follows:**

1. Unlock the latches at the top and bottom.

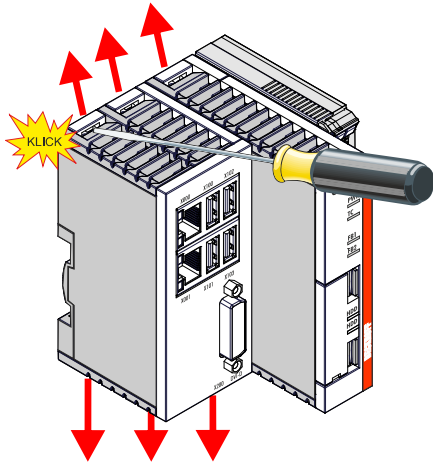

2. Place the Embedded PC at the front of the mounting rail. Slightly press the Embedded PC onto the mounting rail until a soft click can be heard and the Embedded PC has latched.

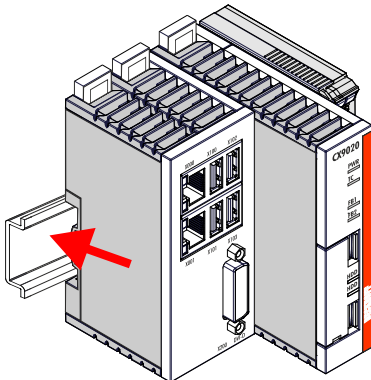

3. Then lock the latches again.

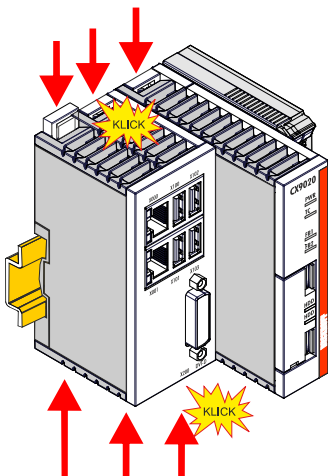

⇒ You have installed the Embedded PC successfully. Double-check the correct installation and latching of the Embedded PC on the mounting rail.

### 6.1.3 MicroSD card installation and removal

#### ● Loss of data

**i** MicroSD cards are subjected to heavy load during operation and have to withstand many write cycles and extreme ambient conditions. MicroSD cards from other manufacturer may fail, resulting in data loss.

Only use industrial MicroSD cards provided by Beckhoff.

The card for the operating system must be inserted in the upper slot (Slot 1). The lower slot (Slot 2) is intended for a further MicroSD card. Data or additional programs can be stored here.

The eject mechanism is based on the push/push principle. The installation and removal of the MicroSD cards is illustrated in the following.

Requirements:

- The Embedded PC must be switched off. The MicroSD cards may only be installed or removed when the Embedded PC is switched off.

#### Removing the MicroSD card

1. Gently push the MicroSD card.  
A soft click can be heard when the card is released.
2. The card is lifted by approx. 2-3 mm from the housing. Pull out the card.

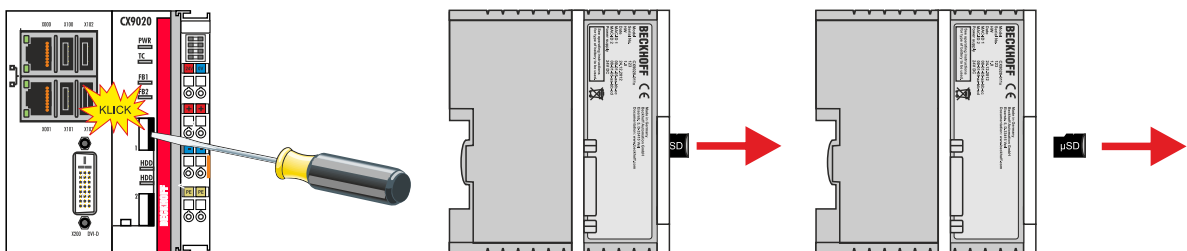

#### Installing a MicroSD card

1. Push the MicroSD card into the Micro SD card slot.

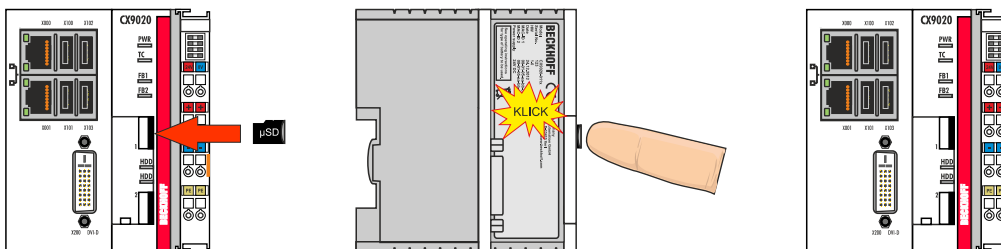

2. A soft click can be heard when the MicroSD card engages.

⇒ The card is positioned correctly, if it is located approx. 1 mm lower than the front of the housing.

### 6.1.4 Installing passive EtherCAT Terminals

**Incorrectly installed passive EtherCAT Terminals**

The E-bus signal between an Embedded PC and the EtherCAT Terminals can be impaired due to incorrectly installed passive EtherCAT Terminals.

Passive EtherCAT Terminals should not be installed directly on the power supply unit.

EtherCAT Terminals that do not take part in active data exchange are referred to as passive terminals. Passive EtherCAT Terminals have no process image and do not require current from the terminal bus (E-bus).

Passive EtherCAT Terminals (e.g. EL9195) can be detected in TwinCAT. In the tree structure the EtherCAT Terminal is displayed without process image, and the value in column "E-bus (mA)" does not change, compared to the preceding EtherCAT Terminal.

Number	Box Name	Ad...	Type	In Size	Out Size	E-Bus (mA)
1	Term 7 (EK1200)		EK1200			
2	Term 8 (EL2828)	1001	EL2828	1.0	1890	
3	Term 9 (EL2828)	1002	EL2828	1.0	1780	
4	Term 10 (EL9195)		EL9195			1780
5	Term 11 (EL2828)	1003	EL2828	1.0	1670	
6	Term 12 (EL9011)		EL9011			

Fig. 18: Identifying a passive EtherCAT Terminal in TwinCAT.

The entry "Current consumption via E-Bus" in the technical data of an EtherCAT Terminal indicates whether a particular EtherCAT Terminal requires power from the terminal bus (E-bus).

The following diagram shows the permissible installation of a passive EtherCAT Terminal. The passive EtherCAT Terminal was not directly attached to the power supply unit.

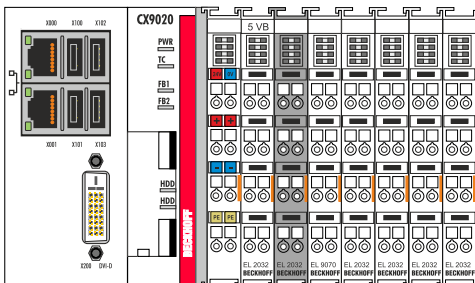

Fig. 19: Passive EtherCAT Terminals, permissible installation.

The following diagram shows the invalid installation of a passive EtherCAT Terminal.

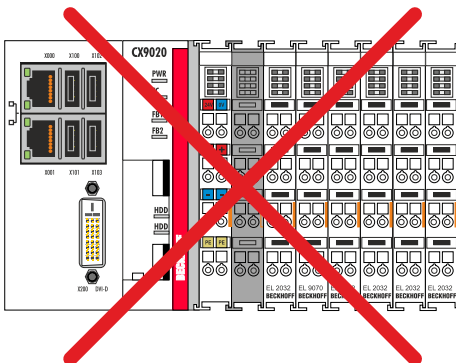

Fig. 20: Passive EtherCAT Terminals, invalid installation.

## 6.2 Connecting the power supply

**NOTICE**

**Damage to the Embedded PCs**  
 The Embedded PCs may be damaged during wiring.

- The cables for the power supply should only be connected in de-energized state.

The power supply terminals require an external voltage source, which provides 24 V DC (-15% / +20%). The power supply terminal must provide 4 A at 24 V, in order to ensure the operation of the Embedded PCs in all situations.

The cabling of the Embedded PC in the control cabinet must be done in accordance with the standard EN 60204-1:2006 PELV = Protective Extra Low Voltage:

- The "PE" and "0 V" conductors of the voltage source for a basic CPU module must be on the same potential (connected in the control cabinet).
- Standard EN 60204-1:2006, section 6.4.1:b stipulates that one side of the circuit, or a point of the energy source for this circuit must be connected to the protective earth conductor system.

**Connection example**

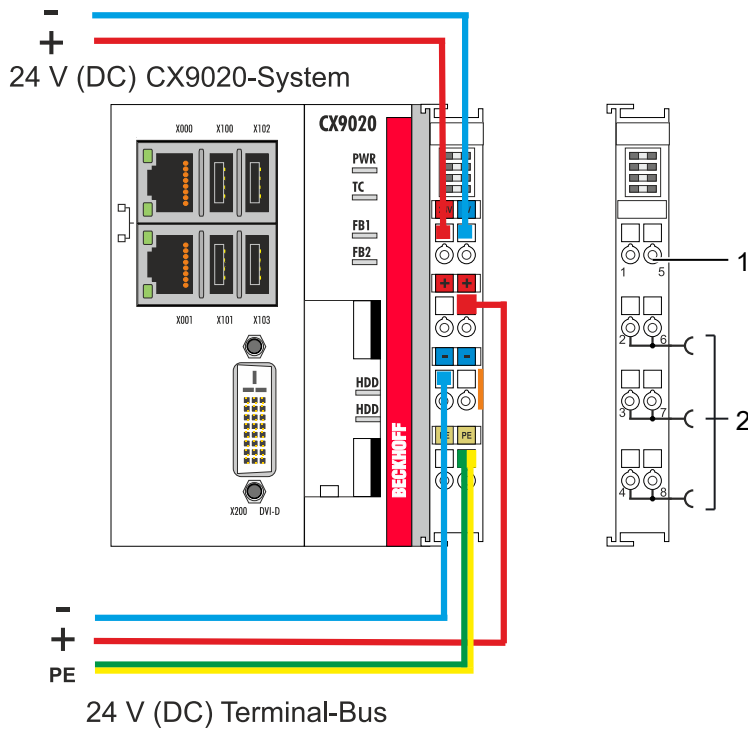

Table 19: Legend for the connection example

No.	Description
1	The upper spring-loaded terminals identified with "24 V" and "0 V" supply the Embedded PC and the Terminal Bus (data transfer via K- or E-bus).
2	The spring-loaded terminals identified as "+", "-", and "PE" supply the Bus Terminals via the power contacts and the sensors or actuators connected to the Bus Terminals.

The cables of an external voltage source are connected to the power supply unit with spring-loaded terminals.

Table 20: Required wire cross-sections and strip lengths.

<b>Conductor cross-section</b>	0,5 ... 2,5 mm <sup>2</sup>	AWG 20 ... AWG 14
<b>Strip length</b>	8 ... 9 mm	0.33 inch

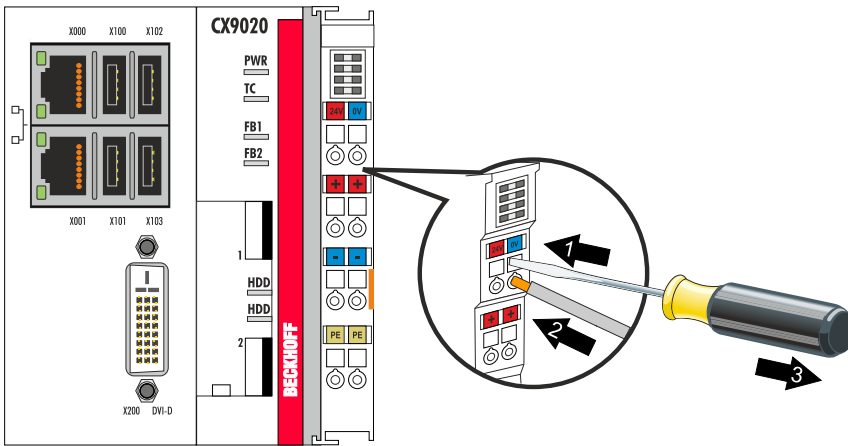

The voltage source has been connected to the power supply unit successfully when the two upper power supply terminal LEDs light up in green.

- The left LED (Us) indicates the supply of the basic CPU module and terminal bus.
- The right LED (Up 24V) indicates the Bus Terminal supply via the power contacts.

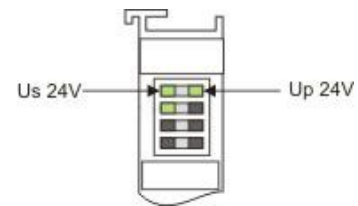

**NOTICE**

**Interrupting / switching off the power supply**

To switch off the Embedded PC, do not disconnect the ground (0 V), because otherwise current may continue to flow via the shielding, depending on the device, and damage the Embedded PC or peripheral devices.

- Always disconnect the 24 V line. Devices connected to the Embedded PC, which have their own power supply (e.g. a Panel) must have the same potential for "PE" and "0 V" as the Embedded PC have (no potential difference).

**Observe the UL requirements**

The CX9020 Embedded PCs are UL certified. The corresponding UL label can be found on the type plate.

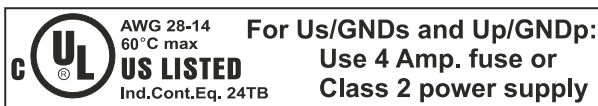

Fig. 21: UL label for CX9020 Embedded PC.

The CX9020 Embedded PCs can thus be used in areas in which special UL requirements have to be met. These requirements apply to the system voltage (Us) and to the power contacts (Up). Application areas without special UL requirements are not affected by UL regulations.

**UL requirements**

- The Embedded PCs must not be connected to unlimited voltage sources.
- Embedded PCs may only be supplied from a 24 V DC voltage source. The voltage source must be insulated and protected with a fuse of maximum 4 A (corresponding to UL248).
- Or the power supply must originate from a voltage source that corresponds to NEC class 2. An NEC class 2 voltage source must not be connected in series or parallel with another NEC class 2 voltage source.

## 6.3 Switching on

Please ensure that the Embedded PC is fully configured before switching on the Embedded PC.

### Switch on the Embedded PC as follows:

1. Ensure that all extension, system and fieldbus modules are connected correctly.
  2. Check whether the right CX2100 power supply unit and the right installation position were selected.
  3. Check whether the Embedded PC is mounted securely on the DIN rail and all required Bus Terminals are connected.
  4. Only then switch on the power supply for the power supply unit.
- ⇒ The Embedded PC starts automatically when the external power supply is switched on. The pre-installed operating system is started and all connected extension, system and fieldbus modules are configured.

## 6.4 Switching off

### ● Loss of data

**i** If the Embedded PC is switched off during operation, data on the CFast card or other hard disks may be lost.

Do not disconnect the Embedded PC during operation.

### Switch off the Embedded PC as follows:

1. Stop all running programs properly, e.g. the control software on the Embedded PC.
2. Shut down the operating system.
3. Do not switch off the external power supply until all other tasks have been completed, in order to switch off the Embedded PC.

## 7 Configuration

### 7.1 Windows Embedded Compact 7

#### 7.1.1 Setting up the audio interface (N020)

Under Windows Embedded Compact 7, the Beckhoff CX configuration tool can be used for the audio settings.

Requirements:

- Embedded PC with audio interface.
- Windows Embedded Compact 7.

**Proceed as follows:**

1. Open the Beckhoff CX configuration tool under **Start > Control Panel > CX Configuration**. The Beckhoff CX configuration tool window opens.
2. Click on the **Miscellaneous** tab.

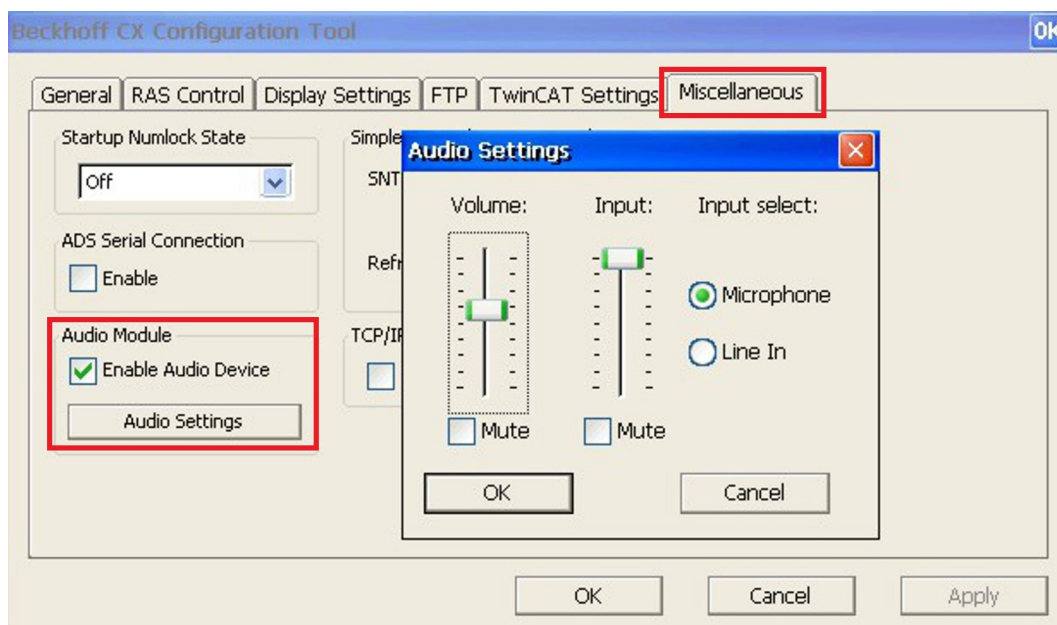

3. Tick the **Enable Audio Device** checkbox.
  4. Click on **Audio Settings** and set the volume for input and output via the sliders.
  5. Select the input source under **Input Select**. Only one input source can be active at any one time.
- ⇒ Confirm the settings with OK, once you have set up the audio interface.

## 7.2 Beckhoff Device Manager

### 7.2.1 Starting the Beckhoff Device Manager

Using the Beckhoff Device Manager, an industrial PC can be configured by remote access with the aid of a web browser. Depending on the image version, access takes place via different protocols and requires different open ports. For older image versions access takes place via the HTTP protocol and Port 80 (TCP). More up-to-date image versions use HTTPS and Port 443 (TCP).

Requirements:

- Host PC and embedded PC must be located in the same network. Depending on the operating system version, the network firewall must allow access via port 80 (HTTP) or port 443 (HTTPS).
- IP address or host name of the embedded PC.

Table 21: Access data for the Beckhoff Device Manager on delivery.

User name	Password
Administrator	1

Start the Beckhoff Device Manager as follows:

1. Open a web browser on the host PC.
2. Enter the IP address or the host name of the industrial PC in the web browser to start the Beckhoff Device Manager.
  - Example with IP address: <https://169.254.136.237/config>
  - Example with host name: <https://CX-16C2B8/config>
3. Enter the user name and password. The start page appears:

⇒ Navigate forward in the menu and configure the industrial PC. Note that modifications only become active once they have been confirmed. It may be necessary to restart the industrial PC.

## 7.2.2 Enabling a remote display

So that you can remotely access an industrial PC with CE operating system, you must first activate Remote Display in the Beckhoff Device Manager. The remote display is disabled by default.

Requirements:

- Host PC and embedded PC must be located in the same network. Depending on the operating system version, the network firewall must allow access via port 80 (HTTP) or port 443 (HTTPS).
- The IP address or the host name of the embedded PC must be known.

Table 22: Access data for the Beckhoff Device Manager on delivery.

Operating system	Access data
Windows Embedded Compact 7	User name: Administrator Password: 1

Enable the remote display as follows:

1. Open a web browser on the host PC.
2. Enter the IP address or the host name of the industrial PC in the web browser to start the Beckhoff Device Manager.
  - Example with IP address: `https://169.254.136.237/config`
  - Example with host name: `https://CX-16C2B8/config`
3. Enter the user name and password. The start page appears.
4. Click **Device** and then click **Boot Opt.**

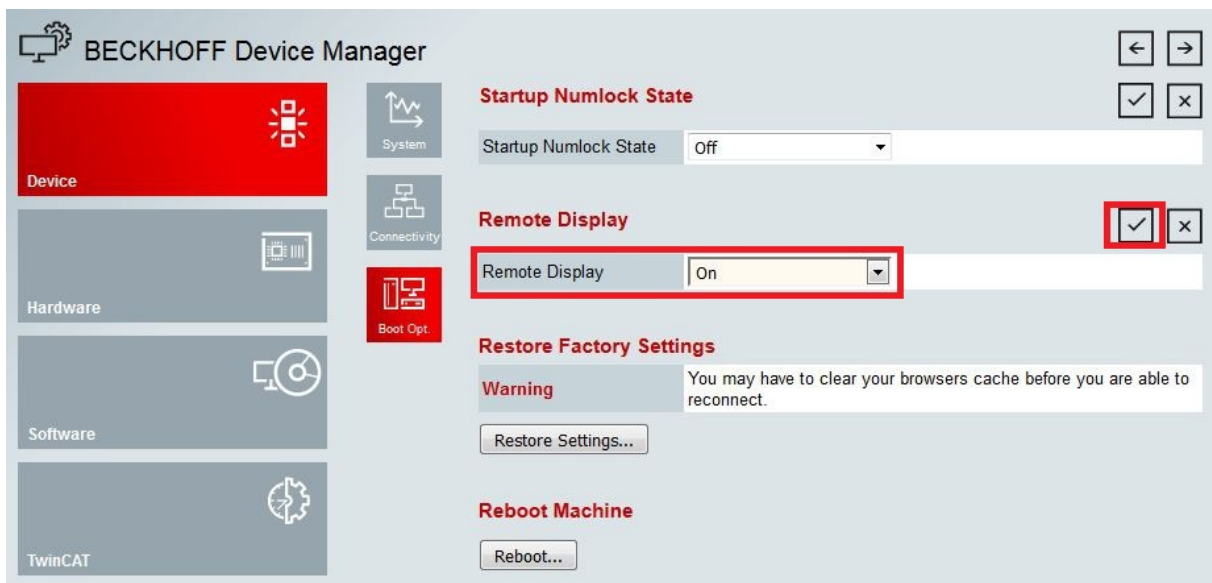

5. Under **Remote Display** select the option **On** and confirm the settings.
  6. In the information window click **OK** to accept the settings.
- ⇒ You have successfully activated Remote Display on the industrial PC. After restarting, you can remotely access your industrial PC.

### 7.2.3 Starting a remote connection

With the aid of the remote display control program (CERHOST), a remote connection can be established and an industrial PC with a CE operating system can be remotely controlled from a host PC.

Prerequisites:

- Remote display is active. See: Enabling a remote display.
- Host name of the embedded PC.
- Remote display control (CERHOST). Download from: [https://www.beckhoff.com/en-en/support/download-finder/search-result/?download\\_group=769277145](https://www.beckhoff.com/en-en/support/download-finder/search-result/?download_group=769277145)

**Start the remote connection as follows:**

1. Unpack the ZIP file on the host PC and run *cerhost.exe*.
2. Click on **File** in the menu bar and then on **Connect**.

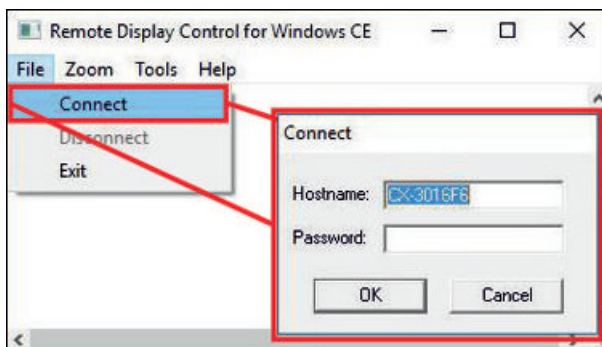

3. Enter the host name of the embedded PC in the **Hostname** field.

⇒ The remote connection is started and the Windows Embedded CE 7 start screen appears.



## 7.3 TwinCAT

### 7.3.1 Tree view

The Tree View chapter can be used as an example for creating a project without actual hardware. All devices and components of an Embedded PCs must be added manually in TwinCAT 3.

The smallest possible configuration of the CX9020 Embedded PC is created as follows in the tree view under TwinCAT 3:

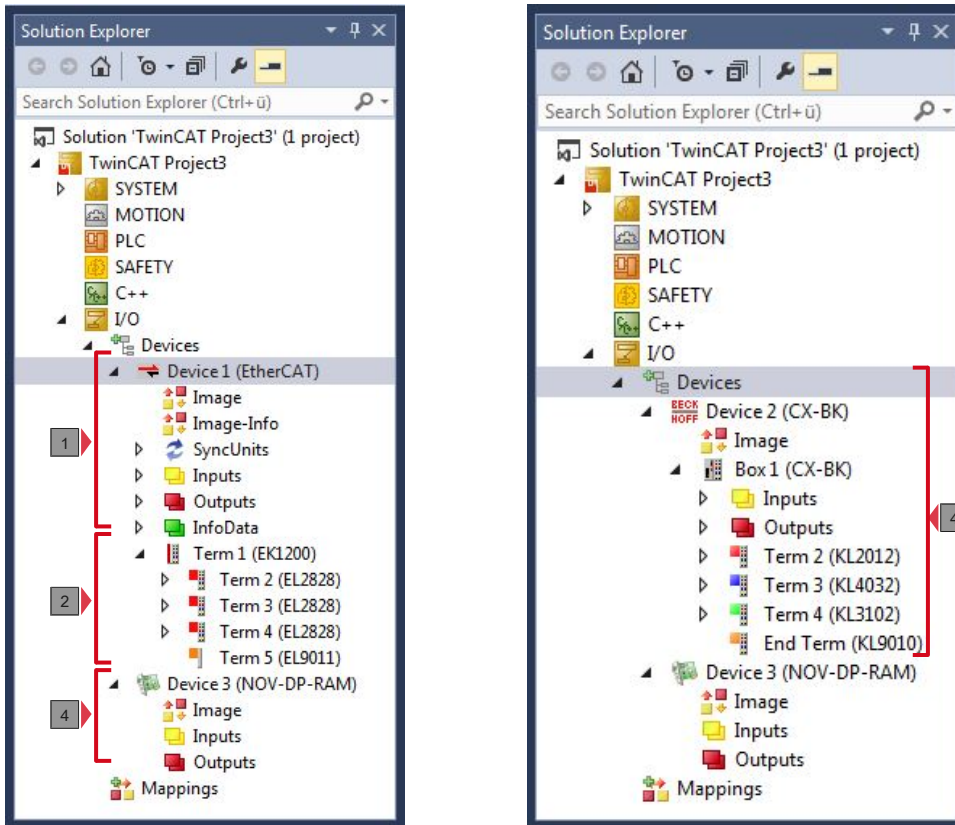

Fig. 22: CX9020 Embedded PC in the tree view of TwinCAT 3, with attached EtherCAT Terminals (left) or Bus Terminals (right).

The configuration in the tree view differs depending on whether EtherCAT Terminals or Bus Terminals are connected to the Embedded PC.

Table 23: Legend for the tree view.

No.	Description
1	The CX9020 Embedded PC with EtherCAT Terminals is added as EtherCAT master. Variables for diagnostic purposes are listed under inputs or outputs.
2	EtherCAT Terminals (E-bus) are displayed under the EK1200 Bus Coupler in the tree view.
3	The CX9020 features NOVDRAM for storing up to 128 kB of data securely. At this point the NOVDRAM handler is created, followed by configuration of the retain variables.
4	If Bus Terminals (K-bus) are used together with an Embedded PC, the Bus Coupler (CX-BK) is added together with the Bus Terminals.

### 7.3.2 Searching for target systems

Before you can work with the devices, you must connect your local computer to the target device. Then you can search for devices with the help of the IP address or the host name.

The local PC and the target devices must be connected to the same network or directly to each other via an Ethernet cable. In TwinCAT a search can be performed for all devices in this way and project planning subsequently carried out.

Prerequisites for this step:

- TwinCAT 3 must be in Config mode.
- IP address or host name of the device.

**Search for the devices as follows:**

1. In the menu at the top click on **File > New > Project** and create a new TwinCAT XAE project.
2. In the tree view on the left click on **SYSTEM**, and then **Choose Target**.



3. Click on **Search (Ethernet)**.

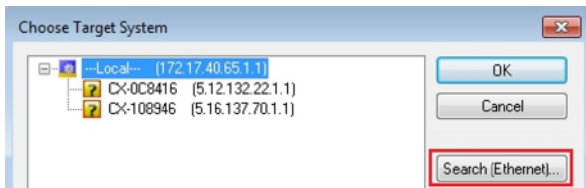

4. Type the host name or the IP address of the device into the **Enter Host Name / IP** box and press **[Enter]**.

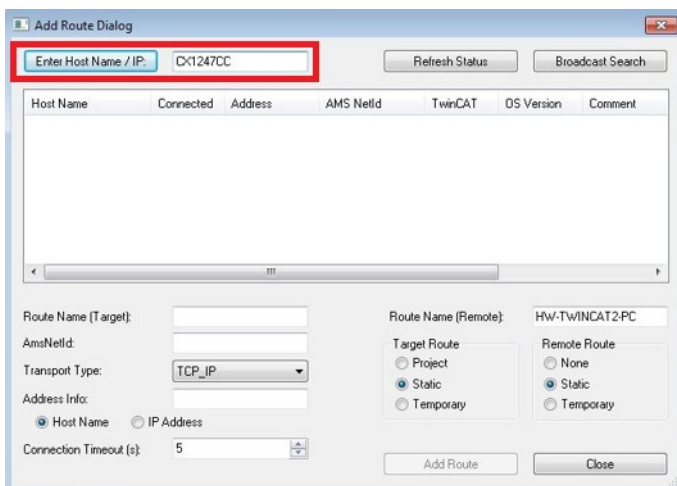

5. Mark the device found and click on **Add Route**.

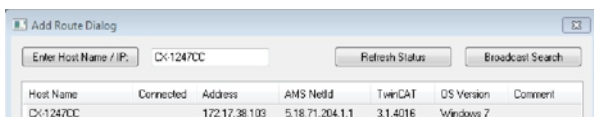

The Logon Information window appears.

Enter the user name and password for the CX in the **User Name** and **Password** fields and click **OK**.

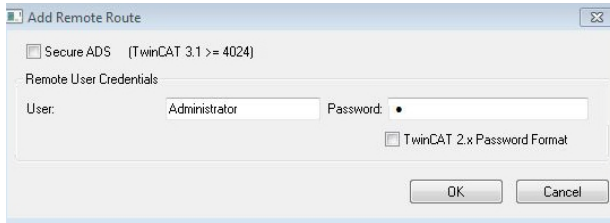

The following information is set as standard in CX devices:  
**User name:** Administrator **Password:** 1

6. If you do not wish to search for any further devices, click on **Close** to close the Add Route Dialog. The new device is displayed in the Choose Target System window.
7. Select the device you want to specify as target system and click **OK**.

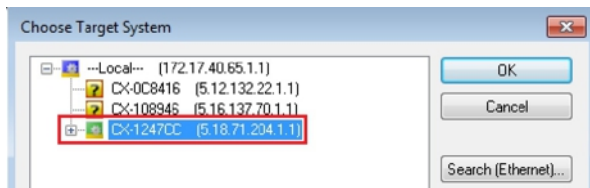

⇒ You have successfully searched for a device in TwinCAT and inserted the device as the target system. The new target system and the host name are displayed in the menu bar.



Using this procedure you can search for all available devices and also switch between the target systems at any time. Next, you can append the device to the tree view in TwinCAT.

### 7.3.3 Scanning an Embedded PC

This step shows how to scan an Embedded PC in TwinCAT and then further configure it.

Prerequisites for this step:

- Selected target device.

**Add the Embedded PC as follows:**

1. Start TwinCAT and open an empty project.
2. In the tree view on the left, right-click on **I/O Devices**.
3. In the context menu click on **Scan**.

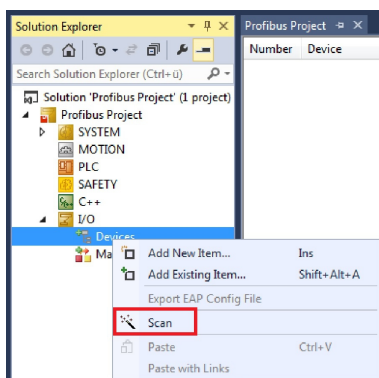

4. Select the devices you want to use and confirm the selection with **OK**. Only devices that are actual available are offered for selection.

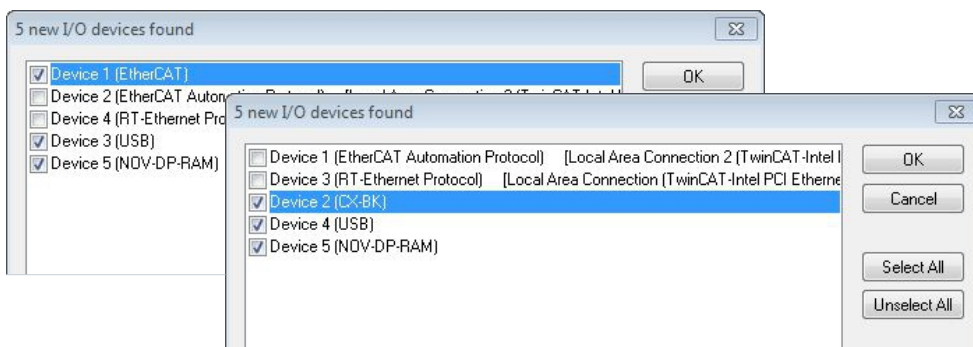

For Embedded PCs with connected Bus Terminals (K-bus) a Bus Coupler device (CX-BK) is displayed. For EtherCAT Terminals (E-bus) the EtherCAT coupler is added automatically.

5. Confirm the request with **Yes**, in order to look for boxes.
6. Confirm the request whether to enable FreeRun with **Yes**.

⇒ The Embedded PC was successfully scanned in TwinCAT and is displayed in the tree view with the inputs and outputs.

The [Tree view \[► 39\]](#) chapter illustrates how Embedded PCs with connected Bus or EtherCAT Terminals are displayed.

## 8 NOVRAM

The NOVRAM can be used to reliably save important variable values, such as production data or counter values, in the event of a power failure. The memory size of the NOVRAM is limited and only suitable for smaller data quantities up to 63 kB.

In this chapter, we show you how the NOVRAM is used in TwinCAT 3.

### Operating principle

The NOVRAM (Non-Volatile Random Access Memory) is a special memory component that is used to reliably save important data. The NOVRAM consists of two sections, a volatile memory and a non-volatile memory.

TwinCAT only writes to the volatile section of the NOVRAM. In the event of a power failure, the data are automatically copied from the volatile memory into the non-volatile memory. The energy required for this process is supplied by a capacitor. As soon as the power supply is restored, the data are automatically copied back into the volatile memory so that TwinCAT can continue to use them.

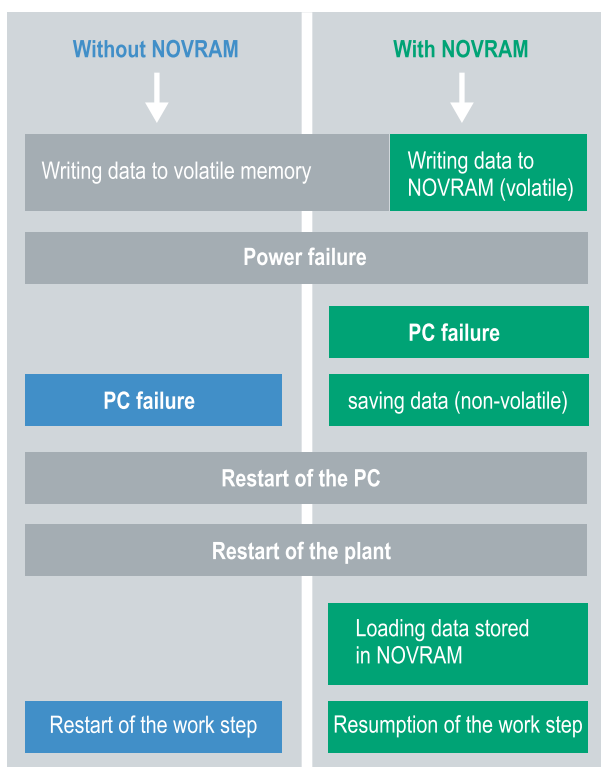

Fig. 23: Controller behavior with and without NOVRAM.

### Memory size

The NOVRAM has a capacity of 128 kB. However, for reasons of data consistency, effectively less than 63 kB of data can be securely saved in the NOVRAM. The data are saved cyclically and alternately based on the dual buffer principle, in order to avoid the risk of data inconsistency.

### Requirements

Development Environment	Target platforms	Hardware	PLC libraries to include
TwinCAT 3.1 Build: 4020	PC or CX (x86, x64, Arm®)	CX70xx, CX9020, CX20x0, CX20x2, CX20x3	Tc2_IoFunctions

### Also see about this

📖 Use under TwinCAT 3 [▶ 44]

## 8.1 Use under TwinCAT 3

Under TwinCAT 3 (from Build 4020) a delta algorithm is used to save data in the NOVRAM. The algorithm does not save all the variables in the NOVRAM. Instead, it searches for changes (delta function) compared to the previous cycle and only saves variables that have changed.

To use the delta algorithm, a Retain Handler must be created in TwinCAT 3, and the relevant variables must be declared in the PLC with the keyword `VAR_RETAIN`.

A new feature of this method is that no function blocks have to be used. The Retain Handler saves data in the NOVRAM in the event of a power failure and makes them available again once the power has been restored.

### 8.1.1 Creating a Retain Handler

Under TwinCAT 3 (from Build 4020) a delta algorithm is used to save data in the NOVRAM. The algorithm does not save all the variables in the NOVRAM. Instead, it searches for changes (delta function) compared to the previous cycle and only saves variables that have changed.

To use the delta algorithm, a Retain Handler must be created in TwinCAT 3, and the relevant variables must be declared in the PLC with the keyword `VAR_RETAIN`.

A new feature of this method is that no function blocks have to be used. The Retain Handler saves data in the NOVRAM in the event of a power failure and makes them available again once the power has been restored.

This chapter describes how to create a Retain Handler in TwinCAT 3. The Retain Handler saves data in the NOVRAM and makes them available again. In other words, important variable values such as production data or counter values are retained during a restart or power failure.

Requirements for this step:

- TwinCAT 3.1 Build: 4020.
- A target device selected in TwinCAT.

**Create the Retain Handler as follows:**

1. Right-click on **Devices** in the tree view on the left-hand side.
2. In the context menu click on **Scan**.

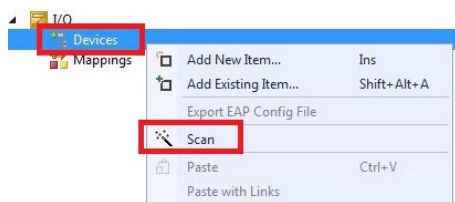

3. Select **Device (NOV-DP-RAM)** and confirm with **OK**.

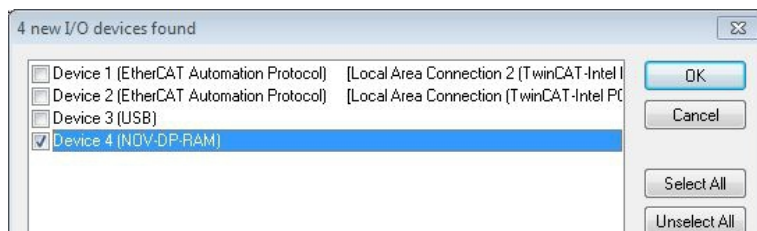

4. Click on **Yes** to search for boxes.

- Click on **Device (NOV-DP-RAM)** in the tree view on the left-hand side and then on the tab **Generic NOV-DP-RAM Device**.

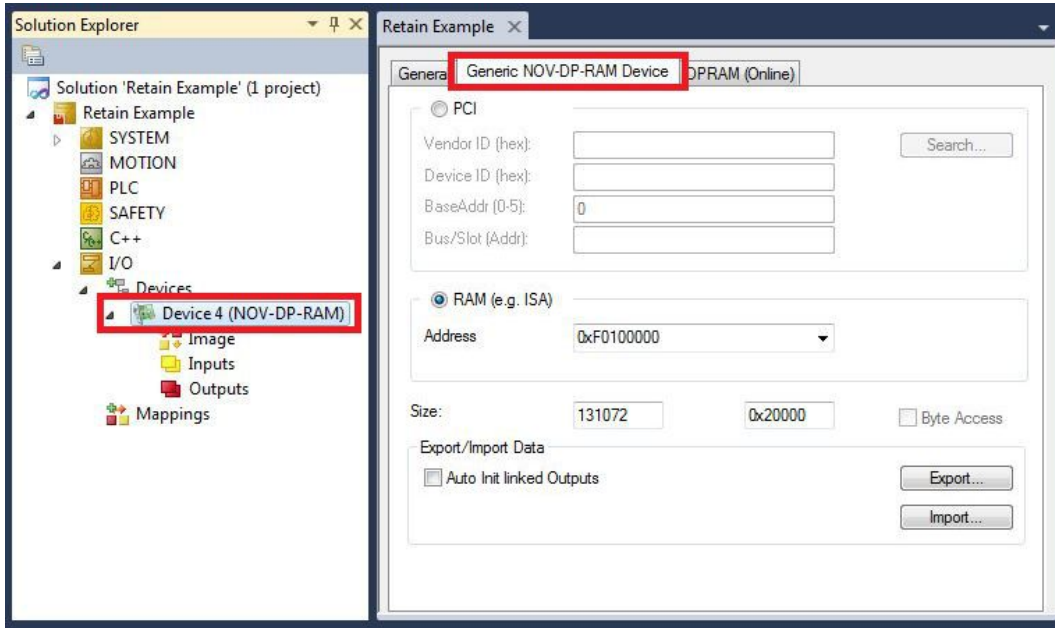

- Click the option **RAM**.
- Right-click on **Device (NOV-DP-RAM)** in the tree view and then on **Add New Item**.

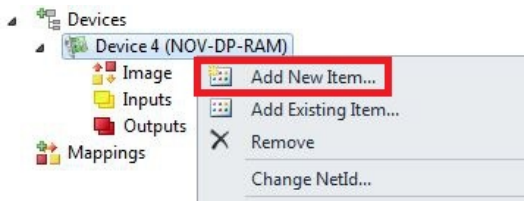

- Select the **Retain Handler** and click on **OK**.



⇒ You have successfully created a Retain Handler in TwinCAT.

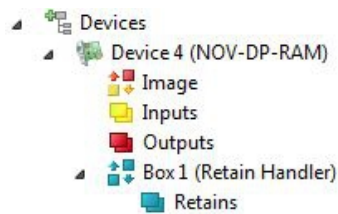

In the next step you can create retain variables in the PLC and link them with the Retain Handler.

## 8.1.2 Creating and linking variables

Once you have created a Retain Handler in TwinCAT, you can declare variables in the PLC and link them to the Retain Handler. The variables have to be identified in the PLC with the keyword VAR\_RETAIN.

Prerequisite for this step:

- A PLC project created in TwinCAT.

**Create variables as follows:**

1. Create the variables in your PLC project in a VAR\_RETAIN area.

```

1  PROGRAM MAIN
2
3  VAR_RETAIN
4      x      :UINT;
5      y      :UINT;
6      z      :UINT;
7  END_VAR
8
9  VAR
10
11     datain  AT$I*: REAL;
12     dataout AT$Q*: BYTE;
13
14 END_VAR

```

2. Click on **Build** in the toolbar at the top, then on **Build Solution**.

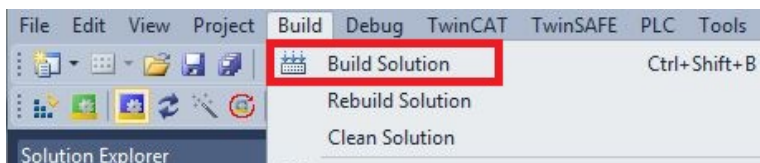

3. Click on **PLC Instance** in the tree view on the left and then on the tab **Data Area**.

Ar...	Name	Type	S..	CS	Ele...	Retain Hdl	Ow...	Co...
+ 0 (0)	PlcTask Inputs	Input...	5...	<input checked="" type="checkbox"/>	1 Sy...			
+ 1 (0)	PlcTask Outputs	Outp...	5...	<input checked="" type="checkbox"/>	4 Sy...			
+ 3 (0)	PlcTask Internal	Inter...	5...	<input checked="" type="checkbox"/>	12 S...			
- 4 (0)	PlcTask Retains	Retai...	5...	<input checked="" type="checkbox"/>	3 Sy...	00000000		
	MAIN.x	UINT	2...					
	MAIN.y	UINT	2...					
	MAIN.z	UINT	2...					

4. Under **Retain Hdl**, select the Retain Handler that you have created.

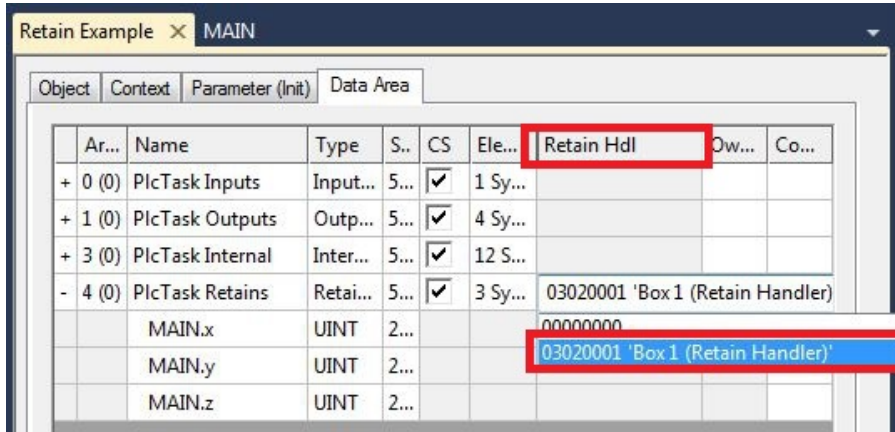

⇒ After selecting a Retain Handler as a target, the symbols in the tree view are linked and a mapping is created.  
 In the tree view the variables are created from the PLC under the Retain Handler and linked to the variables from the PLC instance.

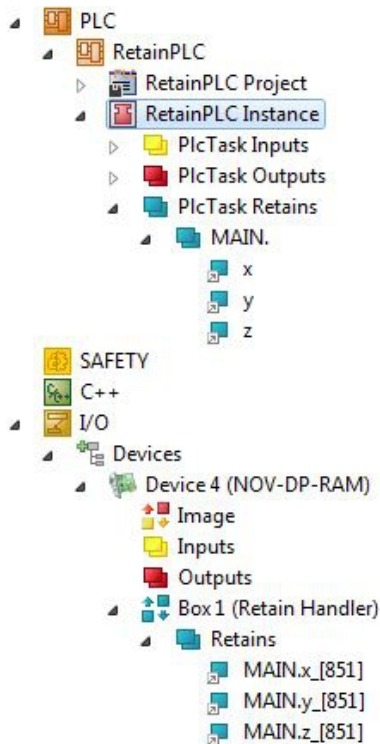

An existing link is displayed with an arrow symbol.

### 8.1.3 Writing speed of the Retain Handler

The Retain Handler takes a certain amount of time to search for changes (delta function) in the variables and save them in the NOVRAM.

The following diagrams provide an overview of how long the Retain Handler needs to save a particular data quantity in the NOVRAM. Use the diagrams to select your task cycle time such that a particular data quantity is saved in the NOVRAM within the selected task cycle time.

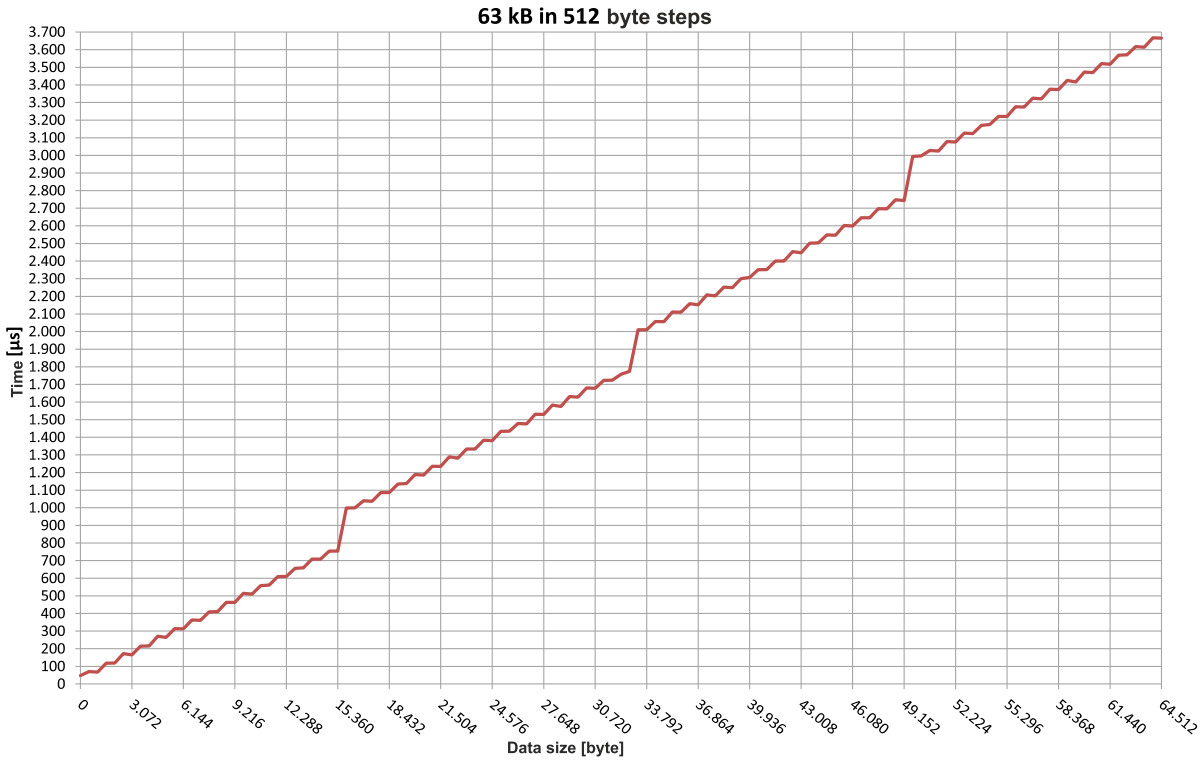

Fig. 24: Retain Handler write speed, up to 63 kB in 512 byte steps.

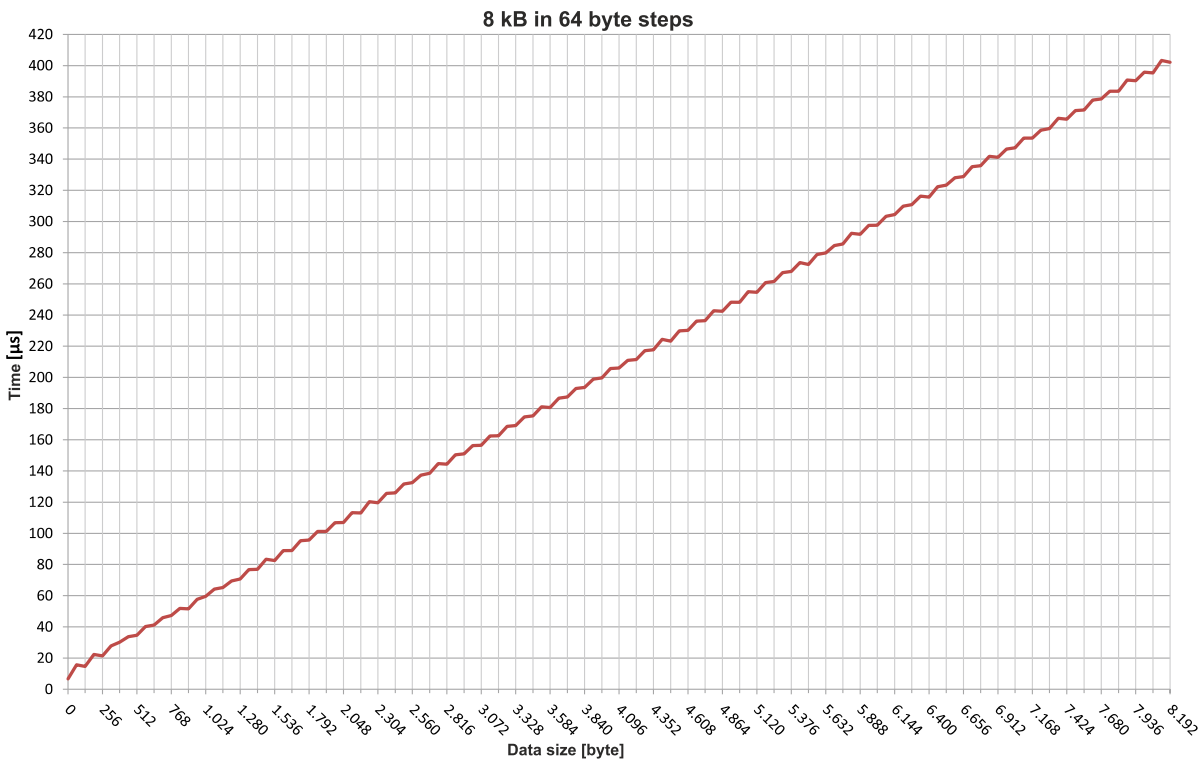

Fig. 25: Retain Handler write speed, up to 8 kB in 64 byte steps.

### 8.1.4 Deleting variables under the Retain Handler

If variables are deleted from the PLC, the link with the Retain Handler is cancelled. However, the variables continue to be shown under the Retain Handler and are not deleted automatically.

Under TwinCAT 3 the variables have to be deleted manually.

Prerequisites for this step:

- Variables declared with VAR\_RETAIN were deleted from the PLC.

Delete the variables under the Retain Handler as follows:

1. The variable GVL\_Retain.iInt under the Retain Handler is to be deleted.

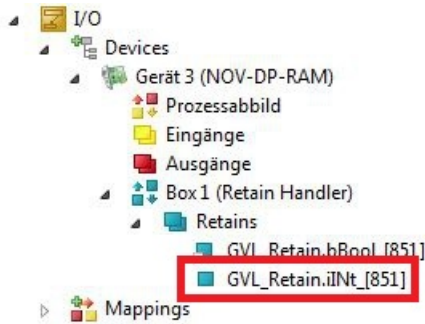

2. Right-click on the **Retain Handler** in the tree view on the left.
3. In the context menu click on **Optimize Retain Variables**.

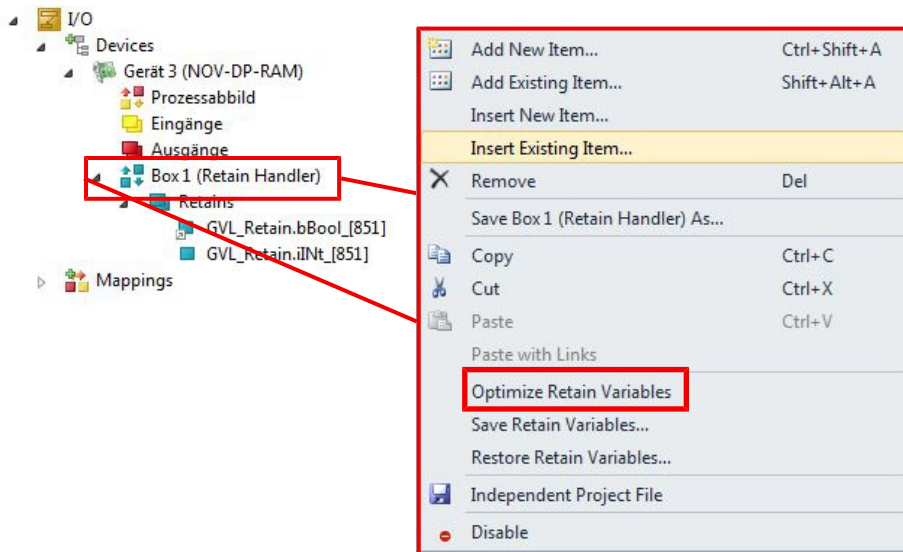

⇒ The variable under the Retain Handler is deleted.

## 9 1-second UPS (persistent variables)

**i** **Loss of data**

Use only TwinCAT to control the 1-second UPS and save only persistent data with a maximum size of 1 MB. Use beyond this may result in data loss or corrupt data.

The 1-second UPS is an UltraCap capacitor that continues to supply the processor with power in the event of a power failure. During this period persistent data can be saved, which are available on switching on again.

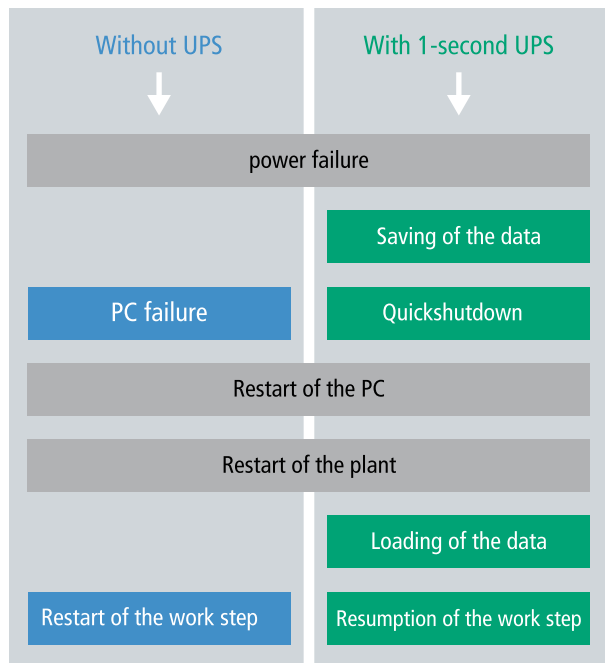

Fig. 26: Behavior of systems in the event of a power failure without and with a 1-second UPS.

Since the 1-second UPS is designed for the entire service life, the holding time is considerably longer with new devices. The capacitors age over the course of time and the holding time decreases. Therefore a maximum of 1 MB persistent data can be reliably saved over the entire service life. Do not save any other data and do not use any other applications to control the 1-second UPS.

Please note that the 1-second UPS does not supply power to the K-bus or the E-bus and that their data may already be invalid when the 1-second UPS is activated. Also, the fieldbus system (or Ethernet) may not work or not work properly once the 1-second UPS was activated.

Table 24: Storage location and names of the files depending on the TwinCAT version.

Development environment	File path	File name
TwinCAT 2	\\TwinCat\Boot\	TCPLC_T_x.wbp TCPLC_T_x.wb~ (backup) The x in the file name stands for the number of the runtime system.
TwinCAT 3	\\TwinCat\3.1\Boot\Plc	Port_85x.bootdata Port_85x.bootdata-old (backup) The x in the file name stands for the number of the runtime system.

## Configuration of the 1-second UPS

- For the CX9020 the 1-second UPS has to be ordered ex factory (CX9020-U900).
- Declare important data such as counter values in the PLC as VAR PERSISTENT. Then call the function block FB\_S\_UPS\_CX9020\_U900 cyclically in TwinCAT in order to control the 1-second UPS (see: [FB\\_S\\_UPS\\_CX9020\\_U900 \[► 52\]](#)).
- Select the mode in the function block in order to specify what should happen in the case of a power failure. Specify, for example, whether persistent data are saved and a quick shutdown is executed (see: [Data types \[► 54\]](#)).
- Subsequently you can check the validity of the variables and monitor whether the persistent variables are loaded without error (see: [Checking the validity of the variables \[► 54\]](#)).

### Sample project:

[https://infosys.beckhoff.com/content/1033/CX9020\\_HW/Resources/2574947979.pro](https://infosys.beckhoff.com/content/1033/CX9020_HW/Resources/2574947979.pro)

## Saving and loading persistent data

The persistent data are saved in the Port\_85x.bootdata file on the memory card. On starting the PLC the Port\_85x.bootdata file is loaded from the memory card, backed up there as Port\_85x.bootdata\_old (backup) and then deleted.

Another current Port\_85x.bootdata file is not written until the system is shut down or the 1-second UPS is activated.

If no Port\_85x.bootdata file exists when starting the embedded PC, the persistent data are invalid and will be deleted (standard setting). The reason for this is that the 1-second UPS was activated before the TwinCAT PLC was started during startup of the embedded PC. In this case no persistent data were saved, since the system was unable to ensure sufficient buffer time for saving the data.

Always call the function block from the PLC and always use the fastest task to do so. In the case of a power failure Beckhoff recommends not calling the rest of the application in order to ensure that sufficient time remains for writing the data.

```
IF NOT FB_S_UPS_CX9020_U900.bPowerFailDetect THEN
  ;//Call programs and function blocks
END_IF
```

The rest of the application influences the CPU load and the CPU load in turn affects the period during which the persistent data are written.

## Loading a backup of the persistent data

A registry setting can be used to determine whether the backup file is deleted or used. The backup file is used by default (setting 0):

```
[HKEY_LOCAL_MACHINE\SOFTWARE\Beckhoff\TwinCAT\Plc]"ClearInvalidPersistentData"= 0
```

If the backup file is to be deleted, the value of "ClearInvalidPersistentData" in the registry must be set to 1.

It is also possible in TwinCAT to specify on the left in the tree view under **PLC** whether the backup file is to be used or not.

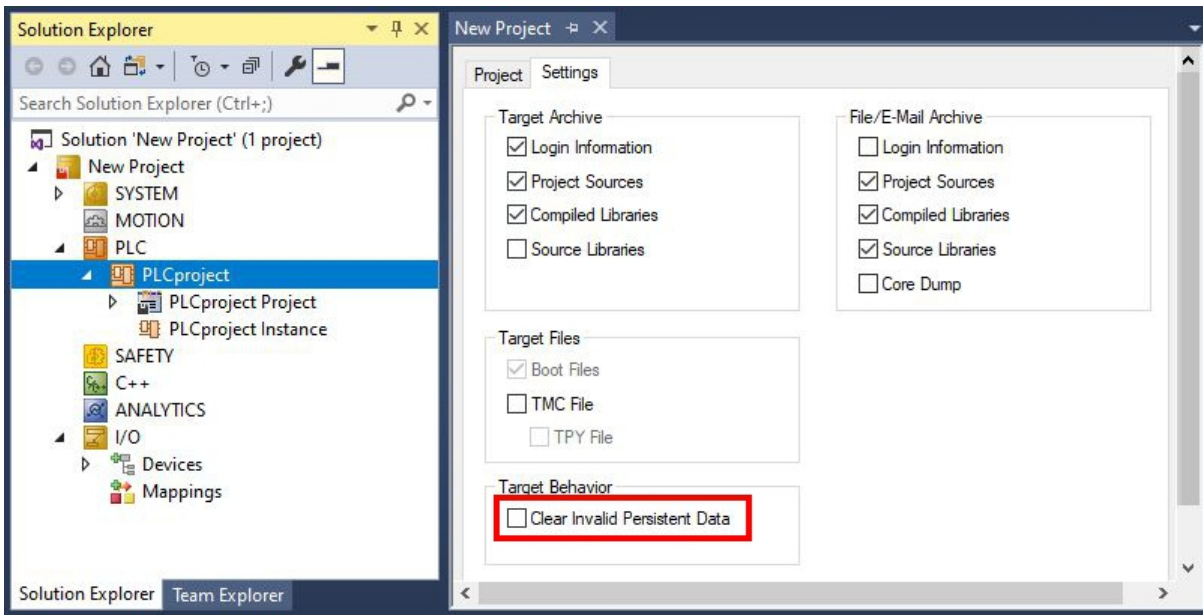

Fig. 27: Loading a backup of the persistent data. Settings in TwinCAT 3.

The backup files will be deleted if the option **Clear Invalid Persistent Data** is activated. Corresponds to registry entry 1.

## 9.1 FB\_S\_UPS\_CX9020\_U900

### NOTICE

#### Loss of data

If other applications or the PLC keep further files open or write to them, file errors may occur if the 1-second UPS switches off the controller.

FB_S_UPS_CX9020_U900	
—sNetID <i>T_AmsNetId</i>	— <i>BOOL</i> bPowerFailDetect
—iPLCPort <i>UINT</i>	— <i>E_S_UPS_State</i> eState
—tTimeout <i>TIME</i>	
—eUpsMode <i>E_S_UPS_Mode</i>	
—ePersistentMode <i>E_PersistentMode</i>	
—tRecoverTime <i>TIME</i>	

In the case of the CX9020 the function block FB\_S\_UPS\_CX9020\_U900 is used to control the 1-second UPS from the PLC. If possible, use the default values of the FB\_S\_UPS\_CX9020\_U900 and call the function block cyclically in the PLC.

The 1-second UPS can be used only for a few seconds in the event of a power failure in order, to save persistent data. The data must be saved in the fast “persistent mode” “SPDM\_2PASS”, even though this can lead to real-time violations. Make sure you configure adequate router memory for saving the persistent data.

Irrespective of the mode and irrespective of whether data were saved or the quick shutdown was executed, the 1-second UPS switches off the mainboard after the discharging of the capacitors.

#### Function block modes

A QuickShutdown is performed automatically in the eSUPS\_WrPersistData\_Shutdown mode (standard setting) after the storage of the persistent data.

In the eSUPS\_WrPersistData\_NoShutdown mode only the persistent data are saved, no QuickShutdown is performed.

In eSUPS\_ImmediateShutdown mode a quick shutdown is executed immediately, without saving data.

In the eSUPS\_CheckPowerStatus mode only a check is performed as to whether a power failure has occurred. If this is the case, the function block only switches back to the PowerOK state after the expiry of tRecoverTime (10s).

 **Inputs**

```
VAR_INPUT
  sNetID      : T_AmsNetId:= ''; (* '' = local netid *)
  iPLCPort    : UINT; (* PLC Runtime System for writing persistent data *)
  tTimeout    : TIME := DEFAULT_ADS_TIMEOUT; (* ADS Timeout *)
  eUpsMode    : E_S_UPS_Mode := eSUPS_WrPersistData_Shutdown; (* UPS mode (w/
wo writing persistent data, w/wo shutdown) *)
  ePersistentMode : E_PersistentMode := SPDM_2PASS; (* mode for writing persistent data *)
  tRecoverTime : TIME := T#10s; (* ON time to recover from short power failure in mode eSUPS_Wr
PersistData_NoShutdown/eSUPS_CheckPowerStatus *)
END_VAR
```

Name	Type	Description
sNetID	T_AmsNetId	AmsNetID of the controller
iPLCPort	UINT	Port number of the PLC runtime system (851 for the first PLC runtime system, 852 for the second PLC runtime system, etc.). If you do not specify a port number, the function block then automatically determines the port of the PLC runtime system.
tTimeout	TIME	Timeout for writing the persistent data or the quick shutdown
eUpsMode	E_S_UPS_Mode	Defines whether persistent data are to be written and whether a quick shutdown is to be executed. The default value is eSUPS_WrPersistData_Shutdown, i.e. a quick shutdown is executed automatically once the persistent data have been saved.
ePersistentMode	E_PersistentMode	Mode for writing the persistent data. Default value is SPDM_2PASS.
tRecoverTime	TIME	Time after which the UPS reverts to the PowerOK status in the event of UPS modes without shutdown. tRecoverTime must be somewhat longer than the maximum holding time of the UPS in order to ensure that the capacitors are fully charged.

 **Outputs**

```
VAR_OUTPUT
  bPowerFailDetect : BOOL; (* TRUE while powerfailure is detected *)
  eState           : E_S_UPS_State := eSUPS_PowerOK; (* current ups state *)
END_VAR
```

Name	Type	Description
bPowerFailDetect	BOOL	TRUE during power failure. FALSE if the supply voltage is present.
eState	E_S_UPS_State	Internal state of the function block

**Global Variables**

```
VAR_GLOBAL
  eGlobalSUpsState : E_S_UPS_State; (*current ups state*)
END_VAR
```

Name	Type	Description
eGlobalSUpsState	E_S_UPS_State	Internal state of the function block as global copy of VAR_OUTPUT
eState	E_S_UPS_State	For values see E_S_UPS_State

**Requirements**

Development environment	Target platform	Hardware	PLC libraries to include
TwinCAT v3.1 B4016	CX9020-U900	1-second UPS	Tc2_SUPS

**9.2 Data types****E\_S\_UPS\_Mode**

With the mode selected in the function block you can specify what should happen in the case of a power failure.

```
eSUPS_WrPersistData_Shutdown: Writing of persistent data and then a QuickShutdown
eSUPS_WrPersistData_NoShutdown: Only writing of the persistent data (no QuickShutdown)
eSUPS_ImmediateShutdown: Only QuickShutdown (no writing of persistent data)
eSUPS_CheckPowerStatus: Only check status (neither writing of persistent data nor a QuickShutdown)
```

**E\_S\_UPS\_State**

The internal state of the function block can be read with E\_S\_UPS\_State.

```
eSUPS_PowerOK:
in all modes: Power supply is OK

eSUPS_PowerFailure:
in all modes: Power supply is faulty (only shown for one PLC cycle)

eSUPS_WritePersistentData:
in mode eSUPS_WrPersistData_Shutdown: Writing of persistent data is active
in mode eSUPS_WrPersistData_NoShutdown: Writing of persistent data is active

eSUPS_QuickShutdown:
in mode eSUPS_WrPersistData_Shutdown: QuickShutdown ist active
in Mode eSUPS_ImmediateShutdown: QuickShutdown is active

eSUPS_WaitForRecover:
in mode eSUPS_WrPersistData_NoShutdown: Wait for the reestablishment of the power supply
in mode eSUPS_CheckPowerStatus: Wait for the reestablishment of the power supply

eSUPS_WaitForPowerOFF:
in mode eSUPS_WrPersistData_Shutdown: Wait for switching off of the PC by the UPS
in mode eSUPS_ImmediateShutdown: Wait for switching off of the PC by the UPS
```

**9.3 Checking the validity of the variables**

For TwinCAT 2 the implicit structure `SystemInfoType.bootDataFlags` can be read in order to determine the validity of the persistent data (see: [SYSTEMINFOTYPE \[► 54\]](#)).

For TwinCAT 3 the implicit variables `PlcAppSystemInfo.BootDataLoaded` and `PlcAppSystemInfo.OldBootData` are available for determining the validity of the persistent data (see: `PlcAppSystemInfo`).

**9.3.1 SYSTEMINFOTYPE**

```
TYPE SYSTEMINFOTYPE
STRUCT
runTimeNo :BYTE;
projectName :STRING(32);
numberOfTasks :BYTE;
onlineChangeCount :UINT;
bootDataFlags :BYTE;
systemStateFlags :WORD;
END_STRUCT
END_TYPE
```

**runTimeNo:** specifies the number of the runtime system (1..4).

**projectName:** project name as STRING.

**numberOfTasks:** number of tasks contained in the runtime system (max. 4).

**onlineChangeCount:** number of online changes since the last complete download.

**bootDataFlags:** State of the boot data (RETAIN and PERSISTENT) after loading. The upper four bits indicate the state of the persistent data, while the lower four bits indicate the state of the retain data.

Bit number	Description
0	RETAIN variables: LOADED (without error)
1	RETAIN variables: INVALID (the back-up copy was loaded, since no valid data was present)
2	RETAIN variables: REQUESTED (RETAIN variables should be loaded, a setting in TwinCAT System Control)
3	reserved
4	PERSISTENT variables: LOADED (without error)
5	PERSISTENT variables: INVALID (the back-up copy was loaded, since no valid data was present)
6	reserved
7	reserved

**systemStateFlags :** Reserved.

When shutting TwinCAT down the PERSISTENT and RETAIN data is written into two files on the hard disk. The path can be specified in TwinCAT System Control by means of the TwinCAT system properties (PLC tab). The standard setting is "<Drive>:\TwinCAT\Boot". The files all have a fixed name with fixed extensions:

File name	Description
TCPLC_P_x.wbp	Boot project (x = number of the run-time system)
TCPLC_S_x.wbp	Packed source code (x = number of the runtime system)
TCPLC_R_x.wbp	RETAIN variables (x = number of the runtime system)
TCPLC_T_x.wbp	PERSISTENT variables (x = number of the runtime system)
TCPLC_R_x.wb~	Backup copy of the RETAIN variables (x = number of the runtime system)
TCPLC_T_x.wb~	Backup copy of the PERSISTENT variables (x = number of the runtime system)

If the persistent or retain variables are not loaded, e.g. because they are invalid, the backup file is loaded by default. In that case bit 1 of the bootDataFlags (for the RETAIN variables) in the PLC and/or bit 5 (for the PERSISTENT variables) is set.

A registry setting can be used to determine whether the backup file is deleted or used. The backup file is used by default (setting 0). If the backup file is to be deleted, the value of "ClearInvalidRetainData" or "ClearInvalidPersistentData" must be set to 1 in the registry under:

```
[HKEY_LOCAL_MACHINE\SOFTWARE\Beckhoff\TwinCAT\Plc]
"ClearInvalidRetainData"=dword:00000000
"ClearInvalidPersistentData"=dword:00000000
```

the value of "ClearInvalidRetainData" or of "ClearInvalidPersistentData" must be set to 1.

Whether the backup file is to be used can also be set in the TwinCAT System Manager in the tree structure on the left under **PLC > PLC Settings**:

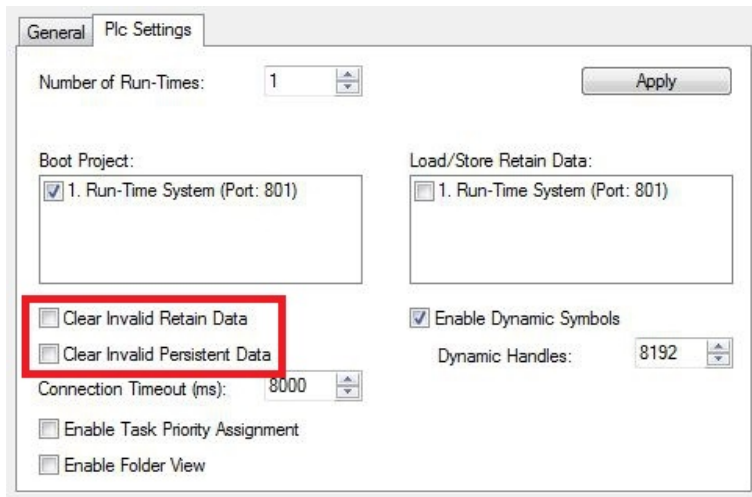

The backup files are deleted if the option **Clear Invalid Retain Data** or **Clear Invalid Persistent Data** is set in the System Manager. Corresponds to registry entry 1.

Development environment	Target platform	PLC libraries to be linked
TwinCAT v2.7.0	PC or CX (x86)	PLCSystem.Lib
TwinCAT v2.8.0	PC or CX (x86)	TcSystem.Lib
TwinCAT v2.10.0 Build >= 1301	CX (ARM)	TcSystem.Lib

### 9.3.2 PlcAppSystemInfo

Each PLC contains an instance of type 'PlcAppSystemInfo' with the name '\_AppInfo'.

The corresponding namespace is 'TwinCAT\_SystemInfoVarList'. This must be specified for use in a library, for example.

```

TYPE PlcAppSystemInfo
STRUCT
  ObjId           : OTCID;
  TaskCnt        : UDINT;
  OnlineChangeCnt : UDINT;
  Flags          : DWORD;
  AdsPort        : UINT;
  BootDataLoaded : BOOL;
  OldBootData    : BOOL;
  AppTimestamp   : DT;
  KeepOutputsOnBP : BOOL;
  ShutdownInProgress : BOOL;
  LicensesPending : BOOL;
  BSODOccured    : BOOL;

  TComSrvPtr     : ITCOMObjectServer;

  AppName        : STRING(63);
  ProjectName    : STRING(63);
END_STRUCT
END_TYPE

```

<b>ObjId</b>	Object ID of the PLC project instance
<b>TaskCnt</b>	Number of tasks in the runtime system
<b>OnlineChangeCnt</b>	Number of online changes since the last complete download
<b>Flags</b>	Reserved
<b>AdsPort</b>	ADS port of the PLC application
<b>BootDataLoaded</b>	PERSISTENT variables: LOADED (without error)
<b>OldBootData</b>	PERSISTENT variables: INVALID (the back-up copy was loaded, since no valid file was present)
<b>AppTimestamp</b>	Time at which the PLC application was compiled
<b>KeepOutputsOnBP</b>	The flag can be set and prevents that the outputs are zeroed when a breakpoint is reached. In this case the task continues to run. Only the execution of the PLC code is interrupted.
<b>ShutdownInProgress</b>	This variable has the value TRUE if a shutdown of the TwinCAT system is in progress. Some parts of the TwinCAT system may already have been shut down.
<b>LicensesPending</b>	This variable has the value TRUE if not all licenses that are provided by license dongles have been validated yet.
<b>BSODOccured</b>	This variable has the value TRUE if Windows is in a BSOD.
<b>TComSrvPtr</b>	Pointer to the TcCOM object server
<b>AppName</b>	Name generated by TwinCAT, which contains the port.
<b>ProjectName</b>	Name of the project

# 10 Error handling and diagnostics

## 10.1 Diagnostic LEDs

Display	LED	Meaning
	PWR	Power supply. The Power LED lights up (green) when the device is connected to a live power supply unit. The LED flashes (red) 8 times per second if there is an error in the power supply. The LED flashes (red) 3 times per second if no or a faulty microSD card is inserted.
	TC	TwinCAT status LEDs TwinCAT is in Run Mode (green) TwinCAT is in Stop Mode (red) TwinCAT is in Config Mode (blue)  Error or crash of the PLC (yellow). Applies only to TwinCAT 3
	FB1	Status LED1 for fieldbus (function is described in the fieldbus interface)
	FB2	Status LED2 for fieldbus (function is described in the fieldbus interface)
	HDD 1	Flashes when accessing the μSD card in slot 1. When reading, the LED flashes green. When writing, the LED flashes yellow.
	HDD 2	Flashes when accessing the μSD card in slot 2. When reading, the LED flashes green. When writing, the LED flashes yellow.

### 10.1.1 K-bus

The power supply unit checks the connected Bus Terminals for errors. The red LED "K-bus ERR" is off if no error is present. The red LED "K-bus ERR" flashes if Bus Terminal errors are present.

Table 25: Diagnostic LEDs in K-Bus mode.

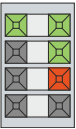
Display	LED	Meaning
	Us 24 V	Power supply for basic CPU module. The LED lights green if the power supply is correct.
	Up 24V	Power supply for terminal bus. The LED lights green if the power supply is correct.
	K-BUS RUN	Diagnostic K-bus. The green LED lights up in order to indicate fault-free operation. "Error-free" means that the communication with the fieldbus system is also running.
	K-BUS ERR	Diagnostic K-bus. The red LED flashes to indicate an error. The red LED blinks with two different frequencies.

The frequency and number of the flashes can be used to determine the error code and the error argument. An error is indicated by the "K-bus ERR" LED in a particular order.

Table 26: K-bus ERR LED, fault indication sequence through the LED.

Order	Meaning
Fast blinking	Starting the sequence
<b>First slow sequence</b>	<b>Error code</b>
No display	Pause, the LED is off
<b>Second slow sequence</b>	<b>Error code argument</b>

Count how often the red LED K-bus ERR flashes, in order to determine the error code and the error argument. In the error argument the number of pulses shows the position of the last Bus Terminal before the error. Passive Bus Terminals, such as a power feed terminal, are not included in the count.

Table 27: K-BUS ERR LED, fault description and troubleshooting.

Error code	Error code argument	Description	Remedy
Persistent, continuous flashing		EMC problems.	<ul style="list-style-type: none"> <li>• Check power supply for undervoltage or overvoltage peaks.</li> <li>• Implement EMC measures.</li> <li>• If a K-bus error is present, it can be localized by a restart of the power supply (by switching it off and then on again)</li> </ul>
3 pulses	0	K-bus command error.	<ul style="list-style-type: none"> <li>• No Bus Terminal inserted.</li> <li>• One of the Bus Terminals is defective; halve the number of Bus Terminals attached and check whether the error is still present with the remaining Bus Terminals. Repeat this procedure until the faulty Bus Terminal has been found.</li> </ul>
4 pulses	0	K-bus data error, break behind the power supply unit.	Check whether the Bus End Terminal 9010 is connected.
	n	Break behind Bus Terminal n	Check whether Bus Terminal n+1 after the power supply unit is connected correctly; replace if necessary.
5 pulses	n	K-bus error in register communication with Bus Terminal n.	Replace Bus Terminal at location n.
6 pulses	0	Error at initialization.	Replace Embedded PC.
	1	Internal data error.	Hardware reset of the Embedded PC (switch off and back on again).
	8	Internal data error.	Hardware reset of the Embedded PC (switch off and back on again).
7 pulses	0	Process data lengths of the set and actual configurations do not correspond.	Check the configuration and the Bus Terminals for consistency.

For some error the LED "K-BUS ERR" does not go out, even if the error was rectified. Switch the power supply for the power supply unit off and back on again to switch off the LED after the error has been rectified.

**State variable**

In TwinCAT there is a State variable under the Bus Coupler for K-bus diagnostics.

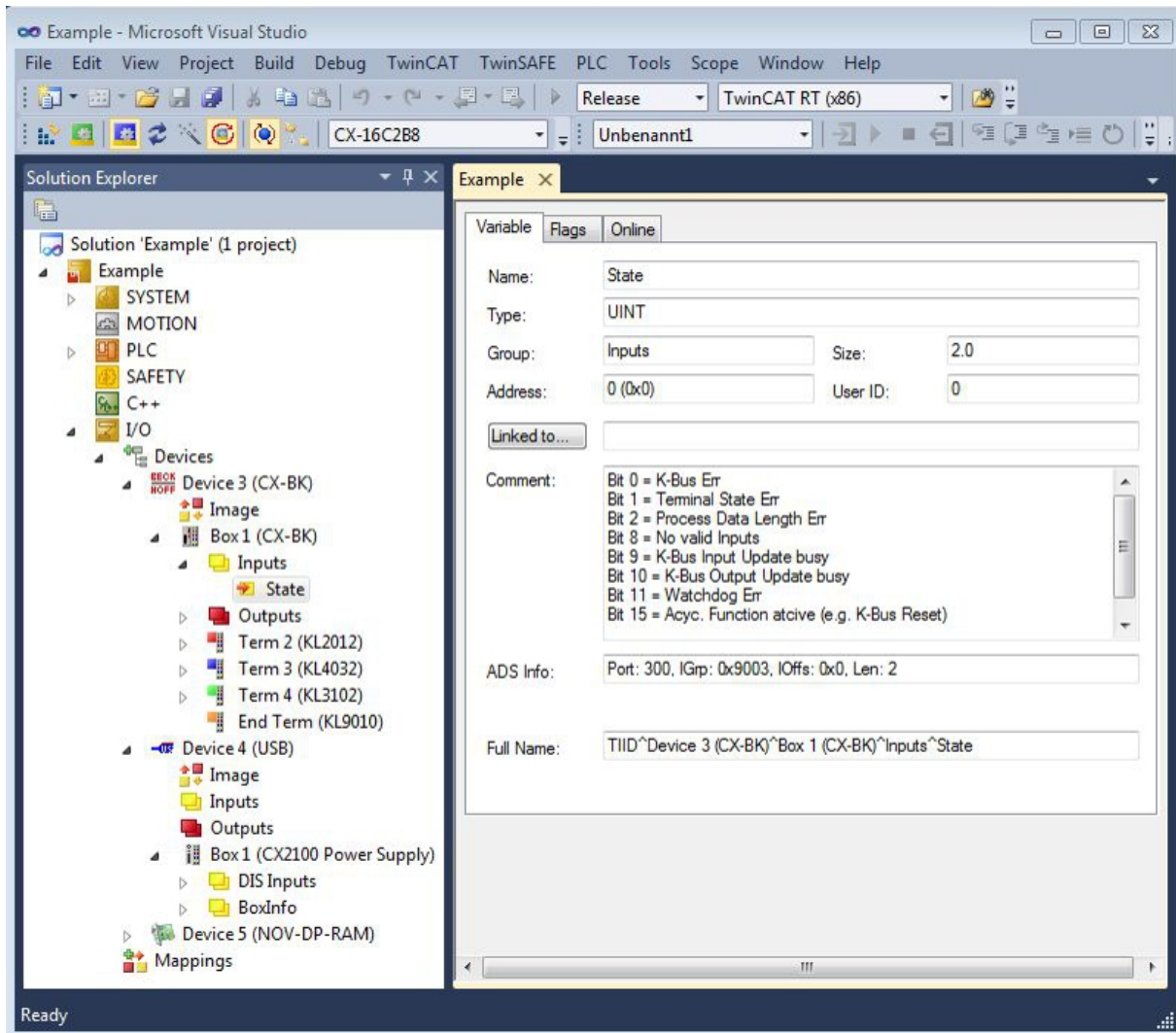

Fig. 28: Status variable for error handling and diagnostics under TwinCAT.

If the value is "0", the K-bus operates synchronous and without error. If the value is  $\neq$  "0" there may be a fault, or it may only be an indication that the K-bus cycle is longer than the task. In which case it would no longer be synchronous with the task. The task time should be faster than 100 ms. We recommend a task time of less than 50 ms. The K-bus update time typically lies between one and five ms.

Table 28: Description of the State variable values.

Bit	Description
Bit 0	K-bus error.
Bit 1	Terminal configuration has changed since the start.
Bit 2	Process image lengths do not match.
Bit 8	(still) no valid inputs.
Bit 9	K-bus input update not yet complete.
Bit 10	K-bus output update not yet complete.
Bit 11	Watchdog.
Bit 15	Acyclic K-bus function active (e.g. K-bus reset).

If there is a K-bus error, this can be reset via the IOF\_DeviceReset function block (in the TcIoFunctions.lib).

### 10.1.2 E-bus

The power supply unit checks the connected EtherCAT Terminals. The "L/A" LED is lit in E-bus mode. The "L/A" LED flashes during data transfer.

Table 29: Diagnostic LEDs in K-Bus mode.

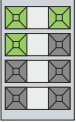
Display	LED	Meaning	
	Us 24 V	Power supply for basic CPU module. The LED lights green if the power supply is correct.	
	Up 24 V	Power supply for terminal bus. The LED lights green if the power supply is correct.	
	L / A	off	E-bus not connected.
		on	E-bus connected / no data traffic.
flashes		E-bus connected / data traffic on the E-bus.	

## 10.2 Faults

Possible faults and their correction

Fault	Cause	Measures
no function after the embedded PC has been switched on	No power supply to the embedded PC Other cause	Check fuse Check the supply voltage and the pin assignment Call Beckhoff Service
Embedded PC does not boot fully	Data carrier ejected from card slot File system damaged (e.g. by switching off while software is running) BIOS setup settings incorrect (does not apply to every model) Other cause	Check the position of the data carrier in the card slot Restart system, import backup Check BIOS setup settings (load defaults) Call Beckhoff Service
Embedded PC boots, software starts, but controller does not work properly	Cause of the fault is either in the software or in parts of the plant outside the embedded PC	Call the machine and software manufacturer

Please make a note of the following information **before** contacting Beckhoff service or support:

1. Precise device ID: CXxxxx-xxxx
2. Serial number/BTN
3. Hardware version
4. any interfaces (N030, N031, B110, ...)
5. TwinCAT version used
6. Any components / software used

The quickest response will come from support / service in your country. Therefore please contact your regional contact. For details please refer to our website at <https://www.beckhoff.com> or ask your distribution partner.

# 11 Care and maintenance

**NOTICE**

**Use of incorrect spare parts**

The use of spare parts not ordered from Beckhoff Service can lead to unsafe and faulty operation.

- Only use spare parts that you have ordered from Beckhoff Service.

Beckhoff industrial PCs are manufactured from components of the highest quality and robustness. They are selected and tested for best interoperability, long-term availability and reliable function under the specified environmental conditions.

Nevertheless, some components of the industrial PC may be subject to a limited service life if they are operated under certain conditions, such as more demanding ambient conditions during operation or during storage, or if they are out of service for long periods of storage.

Beckhoff therefore recommends replacing some of the industrial PC components after the time after which predictions of the remaining service life of such components can no longer be reliably calculated.

Depending on the device used, the following components are involved:

- Battery
- Storage medium
- Fan cartridge

The following table provides recommendations for the regular, precautionary replacement of the PC components:

*Table 30: Replacement recommendations for PC components*

Component	Recommendation for replacement intervals (years)
UPS, battery pack	5 years
2.5-inch hard disk	5 years or after 20,000 operating hours at more than 40 °C or after 30,000 operating hours at less than 40 °C
Fan	5 years
CFAST, SSD, MicroSD, CompactFlash®	10 years
Motherboard battery	5 years

Beckhoff is excluded from liability in the event of possible damage occurring during maintenance work. Before working on the device, you should have established ESD protection to prevent damage to the device through electrostatic discharge.

**ESD protection**

**NOTICE**

**Electrostatic discharge**

The replacement of device components without ESD protection can lead to functional impairment and destruction of the device.

- If possible, apply ESD protection measures during maintenance work.

When working on electronic devices, there is a risk of damage due to ESD (electrostatic discharge), which can impair the function or destroy the device.

Protect the industrial PC and create an ESD-protected environment in which any electrostatic charges are discharged to the ground in a controlled manner and charging is prevented.

An ESD-protected environment can best be created by setting up ESD protection zones. The following measures serve this purpose:

- ESD-compliant floors with sufficient conductivity to the reference potential PE;

- ESD-compatible work surfaces such as tables and shelves;
- Wrist grounding strap, especially for sedentary activities;
- grounded and electrostatically dissipating equipment and operating materials (e.g. tools) within the ESD protection zone.

If it is not possible to create an ESD protection zone, you can still protect the device against ESD damage. For example, the following measures can be used:

- Use conductive mats connected to the ground potential as underlays.
- Dissipate possible charges from your own body by touching grounded metal (e.g. control cabinet door).
- Wear a wrist grounding strap.
- Only remove new electronic components from the ESD packaging (tinted plastic bag) after putting on the wrist grounding strap.
- Do not walk around with electronic components in your hand if they are not in ESD packaging.

## 11.1 Replace the battery

1. Lever the front flap open with a screwdriver and remove it.
2. Carefully pull the battery from the bracket. Use insulated, non-conductive tools if you cannot grip the battery with your fingers.

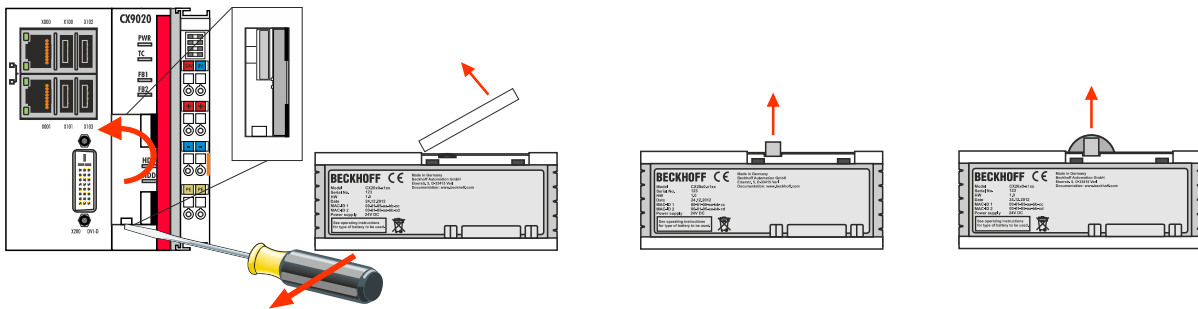

3. Push the new battery into the battery compartment. The positive pole points to the left towards the DVI-D interface.

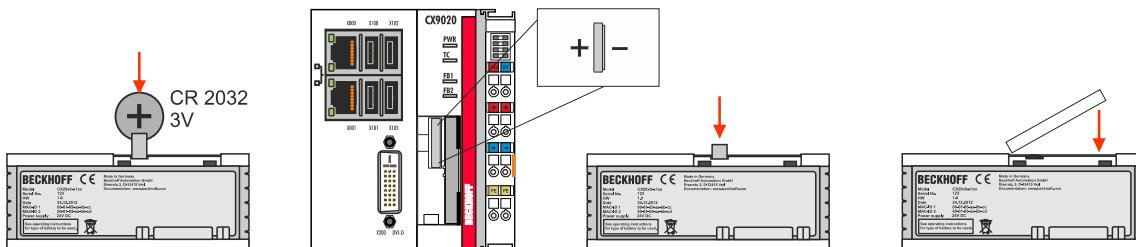

⇒ The battery change is complete. Close the front flap and check the date and time.

## 11.2 Cleaning the Embedded PC

### ⚠ CAUTION

#### Risk of electric shock

Live devices or parts can cause electric shocks. Disconnect the embedded PC from the power supply before cleaning.

Clean only the housing of the embedded PC. Use a soft, moist cleaning cloth for this. Make sure that the ventilation slots of the device are always free and do not clog up. Only use a vacuum cleaner to clean the device. Never use compressed air to clean the embedded PC.

The following cleaning agents and materials are unsuitable and may cause damage:

- corrosive cleaning agents

- solvents
- scouring agents
- hard objects

## 12 Decommissioning

### 12.1 Removing cables

#### NOTICE

##### Electrical voltage

If the power supply is switched on during dismounting, this can lead to damage to the Embedded PCs. Switch off the power supply for the Embedded PCs during dismounting.

Before dismantling the Embedded PC, shut down the Embedded PC and switch off the power supply. Only then can you remove all the cables. Also remove all cables from the first terminal after the power supply terminal.

Requirements:

- Terminate your software and shut down the Embedded PC.
- Switch off the power supply.

**Remove the cables as follows:**

1. Remove the cabling from the Embedded PC.
2. Remove the wiring from the first terminal next to the power supply terminal.
3. Pull the orange strap to remove the first terminal after the power supply terminal by pulling it forward.

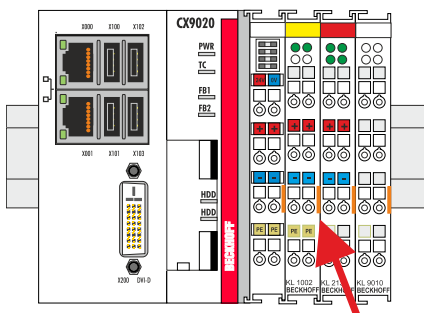

⇒ In the next step the Embedded PC can be removed from the DIN rail and dismantled.

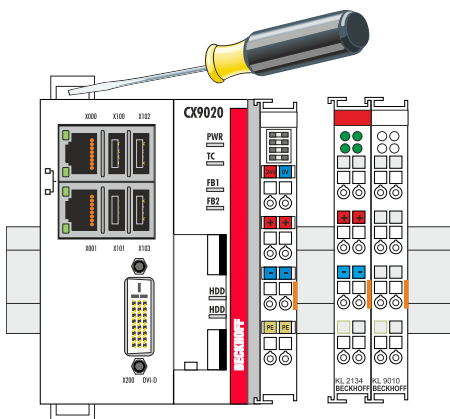

### 12.2 Dismantling the Embedded PC

This chapter explains how to dismantle the Embedded PC and remove it from the mounting rail.

Requirements:

- All cables were removed from the Embedded PC.

**Dismantle the Embedded PC as follows:**

1. Release the DIN rail mounting by pushing the latches outwards with a screwdriver.

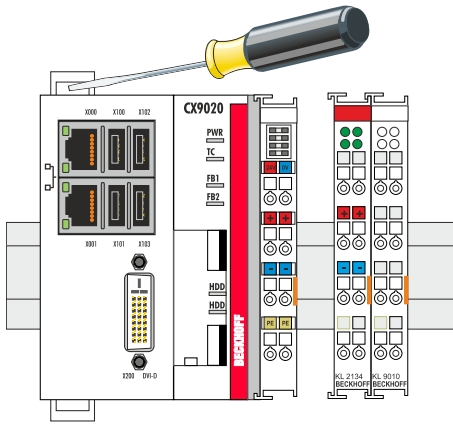

2. Pull the orange strap on the power supply terminal and gently remove the device from the DIN rail.

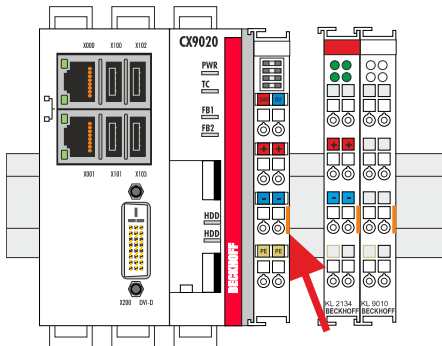

⇒ You have removed the Embedded PC successfully.

**Disposal**

The device must be fully dismantled in order to dispose of it. Electronic components must be disposed of according to national electronic waste regulations.

## 13 Technical data

Table 31: Technical data, dimensions and weights.

Technical data	CX9020
Weight	approx. 590 g
Dimensions (W x H x D)	84 mm x 100 mm x 91 mm

Table 32: Technical data, general data.

Technical data	CX9020
Processor	Arm® Cortex®-A8, 1 GHz
Number of cores	1
Flash memory	2 x slot for microSD card, 512 MB card included (expandable)
Main memory	1 GB DDR3-RAM (not expandable)
Interfaces	2 x RJ45 10/100 Mbit/s (internal switch), 1 x DVI-D, 4 x USB 2.0, 1 x optional interface
Cooling	passive
Diagnostic LED	1 x power, 1 x TC status, 2 x flash access, 2 x bus status
Clock	internal battery-backed clock for time and date (battery replaceable)
Operating system	Windows Embedded Compact 7, English <sup>1)</sup>
Control software	TwinCAT 2 Runtime TwinCAT 3 Runtime (XAR)
Power supply	24 V DC (-15 %/+20 %)
NOVRAM	128 kB
Max. power consumption	5 W
Max. power consumption (with UPS charging)	9 W
Max. power consumption E-bus/K-bus	10 W (5 V/max. 2 A)
Approvals/markings	CE, UL, DNV GL, with ordering option CX2900-0107: ATEX, IECEx, cFMus
Ex marking	ATEX with ordering option CX2900-0107: II 3 G Ex nA IIC T4 Gc II 3 D Ex tc IIIC T135 °C Dc IECEx with ordering option CX2900-0107: Ex nA IIC T4 Gc Ex tc IIIC T135 °C Dc cFMus with ordering option CX2900-0107: Class I, Division 2, Groups A, B, C, D Class I, Zone 2, AEx ec IIC T4 Gc

For the CX9020 the 1-second UPS has to be ordered ex factory (CX9020-U900).

<sup>1)</sup> The support period for the Microsoft Windows Embedded Compact 7 operating system has already expired. Security updates can therefore no longer be provided. TwinCAT is only supported up to and including Build 4024.

Table 33: Technical data, I/O terminals.

Technical data	Description
I/O connection	E-bus or K-bus, automatic recognition
Power supply E-bus/K-bus	2 A
Power contacts current load	max. 10 A
Process data on the K-bus	max. 2048 bytes input and 2048 bytes output
max. number of terminals (K-bus)	64 (255 with K-bus extension)
E-bus process data	max. 3328 bytes
max. number of terminals (E-bus)	up to 65534 terminals.

Table 34: Technical data, environmental conditions.

Technical data	Description
Ambient temperature during operation	-25° C ... +60 °C
Ambient temperature during storage	-40° C ... +85° C see notes under: Transport and storage
Relative humidity	95% no condensation
Vibration resistance	10 frequency sweeps, in 3-axis 10 Hz < f < 58.1 Hz displacement 0.15 mm, constant amplitude 58.1 Hz < f < 500 Hz acceleration 2 g (~ 20 m/s <sup>2</sup> ), constant amplitude conforms to EN 60068-2-6
Shock resistance	1000 shocks in each direction, in 3 axes 15 g, 11 ms conforms to EN 60068-2-27
EMC immunity	conforms to EN 61000-6-2
EMC emission	conforms to EN 61000-6-4
Protection rating	IP20

Table 35: Technical data, graphic specifications.

Technical data	Description
Processor graphics	Integrated graphics, ARM

Table 36: Technical data, interfaces.

Technical data	Description
LAN	2 x RJ 45, 10/100 Mbit/s
USB	4 x USB 2.0 each rated at 500 mA, type A
DVI-D	Resolution on the monitor in pixels: 640 x 480 to 1920 x 1200

*Table 37: Technical data, optional interfaces.*

<b>Technical data</b>	<b>Description</b>
Audio	Line In, Line Out, Mic In
RS232	D-sub connector, 9-pin Electrical isolation 500 V
RS422/RS485	D-sub connector, 9-pin Electrical isolation 500 V
EtherCAT slave	2 x RJ 45, EtherCAT IN and OUT 100 Mbaud
PROFIBUS	D-sub connector, 9-pin 9.6 kbaud to 12 Mbaud
CANopen	D-sub connector, 9-pin 10 kbaud to 1,000 kbaud
PROFINET RT	2 x RJ-45 switches

## 14 Appendix

### 14.1 Accessories

Table 38: microSD cards.

Order number	Description
CX1900-0122	512 MB microSD card
CX1900-0132	16 GB microSD card

### 14.2 Certifications

#### FCC Approvals for the United States of America

##### FCC: Federal Communications Commission Radio Frequency Interference Statement

This equipment has been tested and found to comply with the limits for a Class A digital device, pursuant to Part 15 of the FCC Rules. These limits are designed to provide reasonable protection against harmful interference when the equipment is operated in a commercial environment. This equipment generates, uses, and can radiate radio frequency energy and, if not installed and used in accordance with the instruction manual, may cause harmful interference to radio communications. Operation of this equipment in a residential area is likely to cause harmful interference in which case the user will be required to correct the interference at his own expense.

#### FCC Approval for Canada

##### FCC: Canadian Notice

This equipment does not exceed the Class A limits for radiated emissions as described in the Radio Interference Regulations of the Canadian Department of Communications.

## 14.3 Support and Service

Beckhoff and their partners around the world offer comprehensive support and service, making available fast and competent assistance with all questions related to Beckhoff products and system solutions.

### Download finder

Our [download finder](#) contains all the files that we offer you for downloading. You will find application reports, technical documentation, technical drawings, configuration files and much more.

The downloads are available in various formats.

### Beckhoff's branch offices and representatives

Please contact your Beckhoff branch office or representative for [local support and service](#) on Beckhoff products!

The addresses of Beckhoff's branch offices and representatives round the world can be found on our internet page: [www.beckhoff.com](http://www.beckhoff.com)

You will also find further documentation for Beckhoff components there.

### Beckhoff Support

Support offers you comprehensive technical assistance, helping you not only with the application of individual Beckhoff products, but also with other, wide-ranging services:

- support
- design, programming and commissioning of complex automation systems
- and extensive training program for Beckhoff system components

Hotline: +49 5246 963-157  
e-mail: [support@beckhoff.com](mailto:support@beckhoff.com)

### Beckhoff Service

The Beckhoff Service Center supports you in all matters of after-sales service:

- on-site service
- repair service
- spare parts service
- hotline service

Hotline: +49 5246 963-460  
e-mail: [service@beckhoff.com](mailto:service@beckhoff.com)

### Beckhoff Headquarters

Beckhoff Automation GmbH & Co. KG

Huelshorstweg 20  
33415 Verl  
Germany

Phone: +49 5246 963-0  
e-mail: [info@beckhoff.com](mailto:info@beckhoff.com)  
web: [www.beckhoff.com](http://www.beckhoff.com)

## List of tables

Table 1	Dimensions and weight. ....	11
Table 2	Available optional interfaces for the CX9020. ....	12
Table 3	Legend for the configuration. ....	13
Table 4	Information on the name plate. ....	14
Table 5	CX9020 (1 GHz 1 core), ordering information for software. ....	15
Table 6	USB interfaces (X100, X101, X102, X103), pin assignment. ....	17
Table 7	Ethernet interface X000 and X001, pin assignment. ....	18
Table 8	DVI-D interface X200, pin assignment. ....	19
Table 9	DVI-D interface X200, resolution at the monitor. ....	19
Table 10	Line In /Line Out jack plugs, pin assignment. ....	20
Table 11	RS232 interface X300, pin assignment. ....	21
Table 12	RS422/485 interface, pin assignment. ....	22
Table 13	Default setting, RS485 without echo with end point (terminated). ....	22
Table 14	EtherCAT slave interface X300, pin assignment. ....	23
Table 15	PROFIBUS interface X310, pin assignment. ....	24
Table 16	Wire colors of the PROFIBUS line. ....	24
Table 17	CANopen interface X510, pin assignment. ....	25
Table 18	PROFINET RT interface, pin assignment. ....	26
Table 19	Legend for the connection example. ....	32
Table 20	Required wire cross-sections and strip lengths. ....	32
Table 21	Access data for the Beckhoff Device Manager on delivery. ....	36
Table 22	Access data for the Beckhoff Device Manager on delivery. ....	37
Table 23	Legend for the tree view. ....	39
Table 24	Storage location and names of the files depending on the TwinCAT version. ....	50
Table 25	Diagnostic LEDs in K-Bus mode. ....	58
Table 26	K-bus ERR LED, fault indication sequence through the LED. ....	59
Table 27	K-BUS ERR LED, fault description and troubleshooting. ....	59
Table 28	Description of the State variable values. ....	60
Table 29	Diagnostic LEDs in K-Bus mode. ....	61
Table 30	Replacement recommendations for PC components. ....	63
Table 31	Technical data, dimensions and weights. ....	68
Table 32	Technical data, general data. ....	68
Table 33	Technical data, I/O terminals. ....	69
Table 34	Technical data, environmental conditions. ....	69
Table 35	Technical data, graphic specifications. ....	69
Table 36	Technical data, interfaces. ....	69
Table 37	Technical data, optional interfaces. ....	70
Table 38	microSD cards. ....	71

## List of figures

Fig. 1	Structure of the CX9020 Embedded PC. ....	13
Fig. 2	Name plate example. ....	14
Fig. 3	Nomenclature for the CX9020 Embedded PC. ....	14
Fig. 4	USB interfaces (X100, X101, X102, X103). ....	17
Fig. 5	Ethernet interfaces X000, X001. ....	17
Fig. 6	DVI-D interface X200. ....	19
Fig. 7	Audio interface X300, X301, X302. ....	20
Fig. 8	Line In / Line Out X300, X302 jack plugs. ....	20
Fig. 9	Mic In X301 jack plug. ....	20
Fig. 10	RS232 interface X300. ....	21
Fig. 11	RS485 interface X300. ....	22
Fig. 12	EtherCAT slave interface X300. ....	23
Fig. 13	PROFIBUS interface X310. ....	24
Fig. 14	CANopen interface X510. ....	25
Fig. 15	PROFINET RT interface X300. ....	26
Fig. 16	CX9020 Embedded PC, permissible installation position. ....	27
Fig. 17	CX9020 Embedded PC, invalid installation positions. ....	28
Fig. 18	Identifying a passive EtherCAT Terminal in TwinCAT. ....	31
Fig. 19	Passive EtherCAT Terminals, permissible installation. ....	31
Fig. 20	Passive EtherCAT Terminals, invalid installation. ....	31
Fig. 21	UL label for CX9020 Embedded PC. ....	33
Fig. 22	CX9020 Embedded PC in the tree view of TwinCAT 3, with attached EtherCAT Terminals (left) or Bus Terminals (right). ....	39
Fig. 23	Controller behavior with and without NOVRAM. ....	43
Fig. 24	Retain Handler write speed, up to 63 kB in 512 byte steps. ....	48
Fig. 25	Retain Handler write speed, up to 8 kB in 64 byte steps. ....	48
Fig. 26	Behavior of systems in the event of a power failure without and with a 1-second UPS. ....	50
Fig. 27	Loading a backup of the persistent data. Settings in TwinCAT 3. ....	52
Fig. 28	Status variable for error handling and diagnostics under TwinCAT. ....	60

## **Trademark statements**

Beckhoff®, ATRO®, EtherCAT®, EtherCAT G®, EtherCAT G10®, EtherCAT P®, MX-System®, Safety over EtherCAT®, TC/BSD®, TwinCAT®, TwinCAT/BSD®, TwinSAFE®, XFC®, XPlanar® and XTS® are registered and licensed trademarks of Beckhoff Automation GmbH.

## **Third-party trademark statements**

Arm, Arm9 and Cortex are trademarks or registered trademarks of Arm Limited (or its subsidiaries or affiliates) in the US and/or elsewhere.

Microsoft, Microsoft Azure, Microsoft Edge, PowerShell, Visual Studio, Windows and Xbox are trademarks of the Microsoft group of companies.

More Information:  
[www.beckhoff.com/cx9020](http://www.beckhoff.com/cx9020)

Beckhoff Automation GmbH & Co. KG  
Hülshorstweg 20  
33415 Verl  
Germany  
Phone: +49 5246 9630  
[info@beckhoff.com](mailto:info@beckhoff.com)  
[www.beckhoff.com](http://www.beckhoff.com)

